

1983



---

Information Manual

For Training Purposes Only

# Cutlass RG

Model 172RG

For Training Purposes Only

# NOTICE

AT THE TIME OF ISSUANCE, THIS INFORMATION MANUAL WAS AN EXACT DUPLICATE OF THE OFFICIAL PILOT'S OPERATING HANDBOOK AND FAA APPROVED AIRPLANE FLIGHT MANUAL AND IS TO BE USED FOR GENERAL PURPOSES ONLY.

IT WILL NOT BE KEPT CURRENT AND, THEREFORE, CANNOT BE USED AS A SUBSTITUTE FOR THE OFFICIAL PILOT'S OPERATING HANDBOOK AND FAA APPROVED AIRPLANE FLIGHT MANUAL INTENDED FOR OPERATION OF THE AIRPLANE.

CESSNA AIRCRAFT COMPANY  
26 MAY 1982

# PERFORMANCE - SPECIFICATIONS

<b>SPEED:</b>	
Maximum at Sea Level . . . . .	145 KNOTS
Cruise, 75% Power at 9000 Ft . . . . .	140 KNOTS
<b>CRUISE: Recommended lean mixture with fuel allowance for engine start, taxi, takeoff, climb and 45 minutes reserve.</b>	
75% Power at 9000 Ft . . . . .	Range 720 NM
62 Gallons Usable Fuel . . . . .	Time 5.3 HRS
Maximum Range at 10,000 Ft . . . . .	Range 840 NM
62 Gallons Usable Fuel . . . . .	Time 7.7 HRS
<b>RATE OF CLIMB AT SEA LEVEL . . . . .</b>	<b>800 FPM</b>
<b>SERVICE CEILING . . . . .</b>	<b>16,800 FT</b>
<b>TAKEOFF PERFORMANCE:</b>	
Ground Roll . . . . .	1060 FT
Total Distance Over 50-Ft Obstacle . . . . .	1775 FT
<b>LANDING PERFORMANCE:</b>	
Ground Roll . . . . .	625 FT
Total Distance Over 50-Ft Obstacle . . . . .	1340 FT
<b>STALL SPEED (KCAS):</b>	
Flaps Up, Power Off . . . . .	54 KNOTS
Flaps Down, Power Off . . . . .	50 KNOTS
<b>MAXIMUM WEIGHT:</b>	
Ramp . . . . .	2658 LBS
Takeoff or Landing . . . . .	2650 LBS
<b>STANDARD EMPTY WEIGHT:</b>	
Cutlass RG . . . . .	1598 LBS
Cutlass RG II . . . . .	1633 LBS
<b>MAXIMUM USEFUL LOAD:</b>	
Cutlass RG . . . . .	1060 LBS
Cutlass RG II . . . . .	1025 LBS
<b>BAGGAGE ALLOWANCE . . . . .</b>	
<b>200 LBS</b>	
<b>WING LOADING: Pounds/Sq Ft . . . . .</b>	
<b>15.2</b>	
<b>POWER LOADING: Pounds/HP . . . . .</b>	
<b>14.7</b>	
<b>FUEL CAPACITY: Total . . . . .</b>	
<b>66 GAL.</b>	
<b>OIL CAPACITY . . . . .</b>	
<b>9 QTS</b>	
<b>ENGINE: Avco Lycoming . . . . .</b>	
<b>180 BHP at 2700 RPM</b>	
<b>PROPELLER: Constant Speed, Diameter . . . . .</b>	
<b>76.5 IN.</b>	

The above performance figures are based on the indicated weights, standard atmospheric conditions, level hard-surface dry runways, and no wind. They are calculated values derived from flight tests conducted by the Cessna Aircraft Company under carefully documented conditions and will vary with individual airplanes and numerous factors affecting flight performance.



# Information Manual

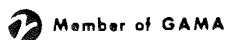
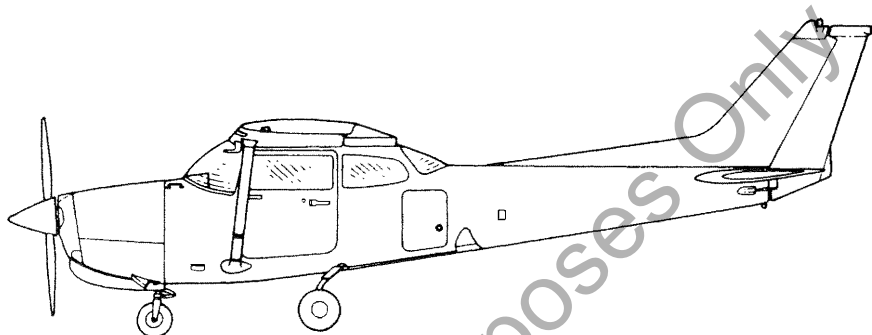

Cessna Aircraft Company

1983 Model 172RG

COPYRIGHT © 1982

Cessna Aircraft Company  
Wichita, Kansas USA

THE REPRINTING OF THIS MANUAL INCORPORATES INFORMATION ISSUED IN REVISION 1 DATED 15 JULY 1983 AND REVISION 2 DATED 1 DECEMBER 1983 FROM THE PILOT'S OPERATING HANDBOOK AND FAA APPROVED AIRPLANE FLIGHT MANUAL.

For Training Purposes Only

# TABLE OF CONTENTS

	SECTION
GENERAL.....	1
LIMITATIONS.....	2
EMERGENCY PROCEDURES.....	3
NORMAL PROCEDURES.....	4
PERFORMANCE.....	5
WEIGHT & BALANCE/ EQUIPMENT LIST .....	6
AIRPLANE & SYSTEMS DESCRIPTIONS .....	7
AIRPLANE HANDLING, SERVICE & MAINTENANCE .....	8
SUPPLEMENTS (Optional Systems Description & Operating Procedures) .....	9

For Training Purposes Only



# SECTION 1 GENERAL

## TABLE OF CONTENTS

	Page
Three View . . . . .	1-2
Introduction . . . . .	1-3
Descriptive Data . . . . .	1-3
Engine . . . . .	1-3
Propeller . . . . .	1-3
Fuel . . . . .	1-3
Oil . . . . .	1-4
Maximum Certificated Weights . . . . .	1-4
Standard Airplane Weights . . . . .	1-5
Cabin And Entry Dimensions . . . . .	1-5
Baggage Space And Entry Dimensions . . . . .	1-5
Specific Loadings . . . . .	1-5
Symbols, Abbreviations And Terminology . . . . .	1-6
General Airspeed Terminology And Symbols . . . . .	1-6
Meteorological Terminology . . . . .	1-7
Engine Power Terminology . . . . .	1-7
Airplane Performance And Flight Planning Terminology . . . . .	1-7
Weight And Balance Terminology . . . . .	1-8

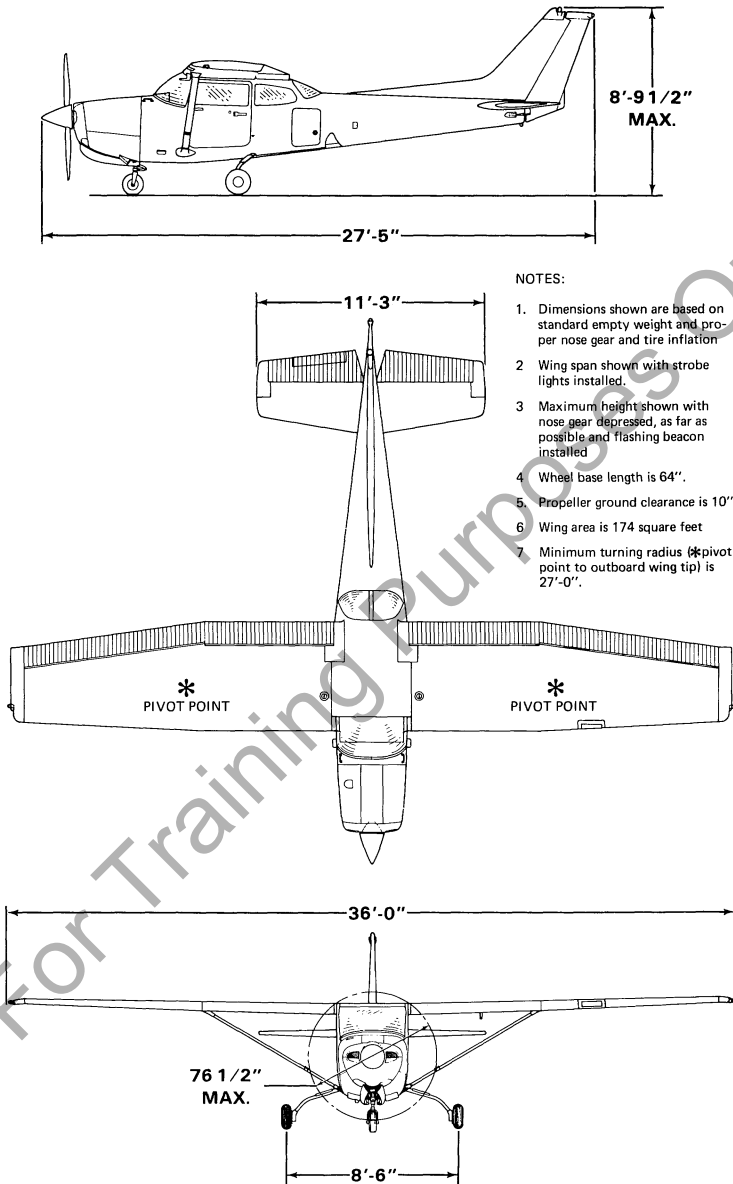

Figure 1-1. Three View

## INTRODUCTION

This handbook contains 9 sections, and includes the material required to be furnished to the pilot by CAR Part 3. It also contains supplemental data supplied by Cessna Aircraft Company.

Section 1 provides basic data and information of general interest. It also contains definitions or explanations of symbols, abbreviations, and terminology commonly used.

## DESCRIPTIVE DATA

### ENGINE

Number of Engines: 1.

Engine Manufacturer: Avco Lycoming.

Engine Model Number: O-360-F1A6.

Engine Type: Normally-aspirated, direct-drive, air-cooled, horizontally-opposed, carburetor equipped, four-cylinder engine with 361 cu. in. displacement.

Horsepower Rating and Engine Speed: 180 rated BHP at 2700 RPM.

### PROPELLER

Propeller Manufacturer: McCauley Accessory Division.

Propeller Model Number: B2D34C220/80VHA-3.5

Number of Blades: 2.

Propeller Diameter, Maximum: 76.5 inches.

Minimum: 75.5 inches.

Propeller Type: Constant speed and hydraulically actuated, with a low pitch setting of 12.0° and a high pitch setting of 26.5° (30 inch station).

### FUEL

Approved Fuel Grades (and Colors):

100LL Grade Aviation Fuel (Blue).

100 (Formerly 100/130) Grade Aviation Fuel (Green).

### NOTE

Isopropyl alcohol or ethylene glycol monomethyl ether may be added to the fuel supply. Additive concentrations shall not exceed 1% for isopropyl alcohol or .15% for ethylene glycol monomethyl ether. Refer to Section 8 for additional information.

Total Capacity: 66 gallons.  
Total Capacity Each Tank: 33 gallons.  
Total Usable: 62 gallons.

#### NOTE

To ensure maximum fuel capacity when refueling and minimize cross-feeding when parked on a sloping surface, place the fuel selector valve in either LEFT or RIGHT position.

## OIL

### Oil Specification:

**MIL-L-6082 Aviation Grade Straight Mineral Oil:** Used when the airplane was delivered from the factory and should be used to replenish the supply during the first 25 hours. This oil should be drained after the first 25 hours of operation. Refill the engine and continue to use until a total of 50 hours has accumulated or oil consumption has stabilized.

**MIL-L-22851 Aviation Grade Ashless Dispersant Oil:** Oil conforming to Avco Lycoming Service Instruction No. 1014, and all revisions and supplements thereto, must be used after first 50 hours or oil consumption has stabilized.

### Recommended Viscosity For Temperature Range:

All temperatures, use multi-viscosity oil or  
Above 16°C (60°F), use SAE 50  
-1°C (30°F) to 32°C (90°F), use SAE 40  
-18°C (0°F) to 21°C (70°F), use SAE 30

#### NOTE

When operating temperatures overlap, use the lighter grade of oil.

### Oil Capacity:

Sump: 8 Quarts.  
Total: 9 Quarts.

## MAXIMUM CERTIFICATED WEIGHTS

Ramp: 2658 lbs.  
Takeoff: 2650 lbs.

Landing: 2650 lbs.

Weight in Baggage Compartment:

Baggage Area 1 - Station 82 to 108: 200 lbs. See note below.

Baggage Area 2 - Station 108 to 124: 50 lbs. See note below.

#### NOTE

The maximum combined weight capacity for baggage areas 1 and 2 is 200 lbs.

### STANDARD AIRPLANE WEIGHTS

Standard Empty Weight, Cutlass RG: 1598 lbs.

Cutlass RG II: 1633 lbs.

Maximum Useful Load, Cutlass RG: 1060 lbs.

Cutlass RG II: 1025 lbs.

### CABIN AND ENTRY DIMENSIONS

Detailed dimensions of the cabin interior and entry door openings are illustrated in Section 6.

### BAGGAGE SPACE AND ENTRY DIMENSIONS

Dimensions of the baggage area and baggage door opening are illustrated in detail in Section 6.

### SPECIFIC LOADINGS

Wing Loading: 15.2 lbs./sq. ft.

Power Loading: 14.7 lbs./hp.

## SYMBOLS, ABBREVIATIONS AND TERMINOLOGY

### GENERAL AIRSPEED TERMINOLOGY AND SYMBOLS

KCAS	<b>Knots Calibrated Airspeed</b> is indicated airspeed corrected for position and instrument error and expressed in knots. Knots calibrated airspeed is equal to KTAS in standard atmosphere at sea level.
KIAS	<b>Knots Indicated Airspeed</b> is the speed shown on the airspeed indicator and expressed in knots.
KTAS	<b>Knots True Airspeed</b> is the airspeed expressed in knots relative to undisturbed air which is KCAS corrected for altitude and temperature.
$V_A$	<b>Maneuvering Speed</b> is the maximum speed at which full or abrupt control movements may be used.
$V_{FE}$	<b>Maximum Flap Extended Speed</b> is the highest speed permissible with wing flaps in a prescribed extended position.
$V_{LE}$	<b>Maximum Landing Gear Extended Speed</b> is the maximum speed at which an airplane can be safely flown with the landing gear extended.
$V_{LO}$	<b>Maximum Landing Gear Operating Speed</b> is the maximum speed at which the landing gear can be safely extended or retracted.
$V_{NO}$	<b>Maximum Structural Cruising Speed</b> is the speed that should not be exceeded except in smooth air, then only with caution.
$V_{NE}$	<b>Never Exceed Speed</b> is the speed limit that may not be exceeded at any time.
$V_S$	<b>Stalling Speed or the minimum steady flight speed</b> at which the airplane is controllable.
$V_{S_0}$	<b>Stalling Speed or the minimum steady flight speed</b> at which the airplane is controllable in the landing configuration at the most forward center of gravity.

$V_X$  **Best Angle-of-Climb Speed** is the speed which results in the greatest gain of altitude in a given horizontal distance.

$V_Y$  **Best Rate-of-Climb Speed** is the speed which results in the greatest gain in altitude in a given time.

## METEOROLOGICAL TERMINOLOGY

OAT **Outside Air Temperature** is the free air static temperature. It is expressed in either degrees Celsius or degrees Fahrenheit.

Standard Temperature **Standard Temperature** is 15°C at sea level pressure altitude and decreases by 2°C for each 1000 feet of altitude.

Pressure Altitude **Pressure Altitude** is the altitude read from an altimeter when the altimeter's barometric scale has been set to 29.92 inches of mercury (1013 mb).

## ENGINE POWER TERMINOLOGY

BHP **Brake Horsepower** is the power developed by the engine.

RPM **Revolutions Per Minute** is engine speed.

MP **Manifold Pressure** is a pressure measured in the engine's induction system and is expressed in inches of mercury (Hg).

## AIRPLANE PERFORMANCE AND FLIGHT PLANNING TERMINOLOGY

Demonstrated Crosswind Velocity **Demonstrated Crosswind Velocity** is the velocity of the crosswind component for which adequate control of the airplane during takeoff and landing was actually demonstrated during certification tests. The value shown is not considered to be limiting.

Usable Fuel **Usable Fuel** is the fuel available for flight planning.

Unusable Fuel **Unusable Fuel** is the quantity of fuel that can not be safely used in flight.

GPH **Gallons Per Hour** is the amount of fuel consumed per hour.

**NMPG**            **Nautical Miles Per Gallon** is the distance which can be expected per gallon of fuel consumed at a specific engine power setting and/or flight configuration.

**g**                **g** is acceleration due to gravity.

## WEIGHT AND BALANCE TERMINOLOGY

**Reference Datum**            **Reference Datum** is an imaginary vertical plane from which all horizontal distances are measured for balance purposes.

**Station**                **Station** is a location along the airplane fuselage given in terms of the distance from the reference datum.

**Arm**                    **Arm** is the horizontal distance from the reference datum to the center of gravity (C.G.) of an item.

**Moment**                **Moment** is the product of the weight of an item multiplied by its arm. (Moment divided by the constant 1000 is used in this handbook to simplify balance calculations by reducing the number of digits.)

**Center of Gravity (C.G.)**            **Center of Gravity** is the point at which an airplane, or equipment, would balance if suspended. Its distance from the reference datum is found by dividing the total moment by the total weight of the airplane.

**C.G. Arm**                **Center of Gravity Arm** is the arm obtained by adding the airplane's individual moments and dividing the sum by the total weight.

**C.G. Limits**            **Center of Gravity Limits** are the extreme center of gravity locations within which the airplane must be operated at a given weight.

**Standard Empty Weight**            **Standard Empty Weight** is the weight of a standard airplane, including unusable fuel, full operating fluids and full engine oil.

**Basic Empty Weight**            **Basic Empty Weight** is the standard empty weight plus the weight of optional equipment.

**Useful Load**            **Useful Load** is the difference between ramp weight and the basic empty weight.



**Maximum Ramp Weight** **Maximum Ramp Weight** is the maximum weight approved for ground maneuver. (It includes the weight of start, taxi and runup fuel.)

**Maximum Takeoff Weight** **Maximum Takeoff Weight** is the maximum weight approved for the start of the takeoff roll.

**Maximum Landing Weight** **Maximum Landing Weight** is the maximum weight approved for the landing touchdown.

**Tare** **Tare** is the weight of chocks, blocks, stands, etc. used when weighing an airplane, and is included in the scale readings. Tare is deducted from the scale reading to obtain the actual (net) airplane weight.

For Training Purposes Only

# SECTION 2 LIMITATIONS

## TABLE OF CONTENTS

	Page
Introduction . . . . .	2-3
Airspeed Limitations . . . . .	2-4
Airspeed Indicator Markings . . . . .	2-4
Power Plant Limitations . . . . .	2-5
Power Plant Instrument Markings . . . . .	2-6
Weight Limits . . . . .	2-6
Center Of Gravity Limits . . . . .	2-7
Maneuver Limits . . . . .	2-7
Flight Load Factor Limits . . . . .	2-7
Kinds Of Operation Limits . . . . .	2-8
Fuel Limitations . . . . .	2-8
Other Limitations . . . . .	2-8
Flap Limitations . . . . .	2-8
Placards . . . . .	2-9

For Training Purposes Only

For Training Purposes Only

## INTRODUCTION

Section 2 includes operating limitations, instrument markings, and basic placards necessary for the safe operation of the airplane, its engine, standard systems and standard equipment. The limitations included in this section and in Section 9 have been approved by the Federal Aviation Administration. Observance of these operating limitations is required by Federal Aviation Regulations.

### NOTE

Refer to Section 9 of this Pilot's Operating Handbook for amended operating limitations, operating procedures, performance data and other necessary information for airplanes equipped with specific options.

### NOTE

The airspeeds listed in the Airspeed Limitations chart (figure 2-1) and the Airspeed Indicator Markings chart (figure 2-2) are based on Airspeed Calibration data shown in Section 5 with the normal static source, with the exception of the bottom of the green and white arcs on the airspeed indicator. These are based on a power-off airspeed calibration. If the alternate static source is being used, refer to the airspeed calibration variations between the normal and alternate static sources as shown in Section 5.

Your Cessna is certificated under FAA Type Certificate No. 3A17 as Cessna Model No. 172RG.

## AIRSPPEED LIMITATIONS

Airspeed limitations and their operational significance are shown in figure 2-1.

	SPEED	KCAS	KIAS	REMARKS
V <sub>NE</sub>	Never Exceed Speed	161	164	Do not exceed this speed in any operation.
V <sub>NO</sub>	Maximum Structural Cruising Speed	142	145	Do not exceed this speed except in smooth air, and then only with caution.
V <sub>A</sub>	Maneuvering Speed: 2650 Pounds 2250 Pounds 1850 Pounds	105 96 87	106 98 89	Do not make full or abrupt control movements above this speed.
V <sub>FE</sub>	Maximum Flap Extended Speed: To 10° Flaps 10° - 30° Flaps	130 101	130 100	Do not exceed these speeds with the given flap settings.
V <sub>LO</sub>	Maximum Landing Gear Operating Speed	138	140	Do not extend or retract landing gear above this speed.
V <sub>LE</sub>	Maximum Landing Gear Extended-Speed	161	164	Do not exceed this speed with landing gear extended.
	Maximum Window Open Speed	161	164	Do not exceed this speed with windows open.

Figure 2-1. Airspeed Limitations

## AIRSPPEED INDICATOR MARKINGS

Airspeed indicator markings and their color code significance are shown in figure 2-2.

MARKING	KIAS VALUE OR RANGE	SIGNIFICANCE
White Arc	42 - 100	Full Flap Operating Range. Lower limit is maximum weight $V_{S0}$ in landing configuration. Upper limit is maximum speed permissible with flaps extended.
Green Arc	50 - 145	Normal Operating Range. Lower limit is maximum weight $V_S$ at most forward C.G. with flaps retracted. Upper limit is maximum structural cruising speed.
Yellow Arc	145 - 164	Operations must be conducted with caution and only in smooth air.
Red Line	164	Maximum speed for all operations.

Figure 2-2. Airspeed Indicator Markings

## POWER PLANT LIMITATIONS

Engine Manufacturer: Avco Lycoming.

Engine Model Number: O-360-F1A6.

Maximum Power: 180 BHP rating.

Engine Operating Limits for Takeoff and Continuous Operations:

Maximum Engine Speed: 2700 RPM.

Maximum Cylinder Head Temperature: 500°F (260°C).

Maximum Oil Temperature: 245°F (118°C).

Oil Pressure, Minimum: \*25 psi.

Maximum: 115 psi.

Fuel Pressure, Minimum: 0.5 psi.

Maximum: 8.0 psi.

Fuel Grade: See Fuel Limitations.

Oil Grade (Specification):

MIL-L-6082 Aviation Grade Straight Mineral Oil or

MIL-L-22851 Ashless Dispersant Oil.

Propeller Manufacturer: McCauley Accessory Division.

Propeller Model Number: B2D34C220/80VHA-3.5

Propeller Diameter, Maximum: 76.5 inches.

Minimum: 75.5 inches.

Propeller Blade Angle at 30 Inch Station, Low: 12.0°.

High: 26.5°.

\* 20 psi on airplanes modified by Service Kit SK172-85.

## POWER PLANT INSTRUMENT MARKINGS

Power plant instrument markings and their color code significance are shown in figure 2-3.

INSTRUMENT	RED LINE	GREEN ARC	RED LINE
	MINIMUM LIMIT	NORMAL OPERATING	MAXIMUM LIMIT
Tachometer: S.L. and above  7500 ft. and above	---	2100 - 2500 (wide green arc) 2500 - 2700 (narrow green arc)	2700 RPM
Manifold Pressure	---	15 - 25 in. Hg	---
Oil Temperature	---	100° - 245°F	245°F
Cylinder Head Temperature	---	200° - 500°F	500°F
Fuel Pressure	0.5 psi	0.5 - 8.0 psi	8.0 psi
Oil Pressure	*25 psi	*60 - 90 psi	115 psi
Suction	---	4.5 - 5.4 in. Hg	---
Fuel Quantity	E (2 Gal. Unusable Each Tank)	---	---

Figure 2-3. Power Plant Instrument Markings

## WEIGHT LIMITS

Maximum Ramp Weight: 2658 lbs.

Maximum Takeoff Weight: 2650 lbs.

Maximum Landing Weight: 2650 lbs.

Maximum Weight in Baggage Compartment:

Baggage Area 1 - Station 82 to 108: 200 lbs. See note below.

\* 20 psi (red line) and 50-90 psi (green arc) on airplanes modified by Service Kit SK172-85.

26 May 1982



Baggage Area 2 - Station 108 to 124: 50 lbs. See note below.

#### NOTE

The maximum combined weight capacity for baggage areas 1 and 2 is 200 lbs.

## CENTER OF GRAVITY LIMITS

Center of Gravity Range:

Forward: 36.0 inches aft of datum at 1950 lbs. or less, with straight line variation to 39.5 inches aft of datum at 2650 lbs.

Aft: 46.5 inches aft of datum at all weights.

Moment Change Due To Retracting Landing Gear: +2424 lb.-ins.

Reference Datum: Front face of firewall.

## MANEUVER LIMITS

This airplane is certificated in the normal category. The normal category is applicable to aircraft intended for non-aerobatic operations. These include any maneuvers incidental to normal flying, stalls (except whip stalls), lazy eights, chandelles, and steep turns in which the angle of bank is not more than 60°.

Aerobatic maneuvers, including spins, are not approved.

## FLIGHT LOAD FACTOR LIMITS

Flight Load Factors:

\*Flaps Up: +3.8g, -1.52g

\*Flaps Down: +2.0g

\*The design load factors are 150% of the above, and in all cases, the structure meets or exceeds design loads.

## KINDS OF OPERATION LIMITS

The airplane is equipped for day VFR and may be equipped for night VFR and/or IFR operations. FAR Part 91 establishes the minimum required instrumentation and equipment for these operations. The reference to types of flight operations on the operating limitations placard reflects equipment installed at the time of Airworthiness Certificate issuance.

Flight into known icing conditions is prohibited.

## FUEL LIMITATIONS

2 Standard Tanks: 33 U.S. gallons each.

Total Fuel: 66 U.S. gallons.

Usable Fuel (all flight conditions): 62 U.S. gallons.

Unusable Fuel: 4.0 U.S. gallons.

### NOTE

To ensure maximum fuel capacity when refueling and minimize cross-feeding when parked on a sloping surface, place the fuel selector valve in either LEFT or RIGHT position.

Takeoff and land with the fuel selector valve handle in the BOTH position.

Operation on either left or right tank is limited to level flight only.

With 1/4 tank or less, prolonged uncoordinated flight is prohibited when operating on either left or right tank.

Approved Fuel Grades (and Colors):

100LL Grade Aviation Fuel (Blue).

100 (Formerly 100/130) Grade Aviation Fuel (Green).

## OTHER LIMITATIONS

### FLAP LIMITATIONS

Approved Takeoff Range:

Above 2550 Pounds Takeoff Weight: 0°.

2550 Pounds Takeoff Weight or Less: 0° to 10°.

Approved Landing Range: 0° to 30°.

## PLACARDS

The following information must be displayed in the form of composite or individual placards.

1. In full view of the pilot: (The "DAY-NIGHT-VFR-IFR" entry, shown on the example below, will vary as the airplane is equipped.)

The markings and placards installed in this airplane contain operating limitations which must be complied with when operating this airplane in the Normal Category. Other operating limitations which must be complied with when operating this airplane in this category are contained in the Pilot's Operating Handbook and FAA Approved Airplane Flight Manual.

No acrobatic maneuvers, including spins, approved.  
Flight into known icing conditions prohibited.

This airplane is certified for the following flight operations as of date of original airworthiness certificate:

DAY-NIGHT-VFR-IFR

2. Near airspeed indicator:

MAX SPEED - KIAS  
MANEUVER . . . 106  
GEAR OPER . . . 140  
GEAR DOWN . . . 164

3. On control lock:

CAUTION!  
CONTROL LOCK  
REMOVE BEFORE STARTING ENGINE

SECTION 2  
LIMITATIONS

CESSNA  
MODEL 172RG

4. On the fuel selector valve:

TAKEOFF LANDING	BOTH 62.0 GAL.	ALL FLIGHT ATTITUDES
LEFT 30.0 GAL. LEVEL FLIGHT ONLY		RIGHT 30.0 GAL. LEVEL FLIGHT ONLY
		FUEL SELECTOR
	OFF	OFF

5. On the baggage compartment door:

200 LBS MAX BAGGAGE  
MAX LOAD ON AFT SHELF 50 LBS  
FOR ADDITIONAL LOADING INSTRUCTIONS  
SEE WEIGHT AND BALANCE DATA

6. On flap position indicator:

0° to 10°	130 KIAS	(partial flap range with blue color code; also, mechanical detent at 10°.)
10° to 30°	100 KIAS	(white color code; also mechanical detent at 20°.)

7. Forward of fuel tank filler cap:

FUEL

100LL/100 MIN GRADE AVIATION GASOLINE  
CAP. 33.0 U.S. GAL.  
CAP. 24.0 U.S. GAL. TO BOTTOM OF FILLER COLLAR



For Training Purposes Only

# SECTION 3

# EMERGENCY PROCEDURES

## TABLE OF CONTENTS

	Page
Introduction . . . . .	3-3
Airspeeds For Emergency Operation . . . . .	3-3
<b>OPERATIONAL CHECKLISTS</b>	
Engine Failures . . . . .	3-3
Engine Failure During Takeoff Roll . . . . .	3-3
Engine Failure Immediately After Takeoff . . . . .	3-4
Engine Failure During Flight (Restart Procedures) . . . . .	3-4
Forced Landings . . . . .	3-4
Emergency Landing Without Engine Power . . . . .	3-4
Precautionary Landing With Engine Power . . . . .	3-4
Ditching . . . . .	3-5
Fires . . . . .	3-5
During Start On Ground . . . . .	3-5
Engine Fire In Flight . . . . .	3-6
Electrical Fire In Flight . . . . .	3-6
Cabin Fire . . . . .	3-7
Wing Fire . . . . .	3-7
Icing . . . . .	3-7
Inadvertent Icing Encounter . . . . .	3-7
Static Source Blockage (Erroneous Instrument Reading Suspected) . . . . .	3-8
Landing Gear Malfunction Procedures . . . . .	3-8
Landing Gear Fails To Retract . . . . .	3-8
Landing Gear Fails To Extend . . . . .	3-9
Gear Unsafe Light Illuminates . . . . .	3-9
Gear Up Landing . . . . .	3-9
Landing Without Positive Indication Of Gear Locking . . . . .	3-10
Landing With A Defective Nose Gear (Or Flat Nose Tire) . . . . .	3-10
Landing With A Flat Main Tire . . . . .	3-10
Electrical Power Supply System Malfunctions . . . . .	3-11
Ammeter Shows Excessive Rate of Charge (Full Scale Deflection) . . . . .	3-11
Low-Voltage Light Illuminates During Flight (Ammeter Indicates Discharge) . . . . .	3-11

## TABLE OF CONTENTS (Continued)

	Page
<b>AMPLIFIED PROCEDURES</b>	
Engine Failure . . . . .	3-13
Forced Landings . . . . .	3-14
Landing Without Elevator Control . . . . .	3-14
Fires . . . . .	3-14
Emergency Operation In Clouds (Vacuum System Failure) . . . . .	3-15
Executing A 180° Turn In Clouds . . . . .	3-15
Emergency Descent Through Clouds . . . . .	3-15
Recovery From A Spiral Dive . . . . .	3-16
Inadvertent Flight Into Icing Conditions . . . . .	3-16
Static Source Blocked . . . . .	3-17
Spins . . . . .	3-17
Rough Engine Operation Or Loss Of Power . . . . .	3-18
Carburetor Icing . . . . .	3-18
Spark Plug Fouling . . . . .	3-18
Magneto Malfunction . . . . .	3-18
Engine-Driven Fuel Pump Failure . . . . .	3-18
Low Oil Pressure . . . . .	3-19
Landing Gear Malfunction Procedures . . . . .	3-19
Retraction Malfunctions . . . . .	3-19
Extension Malfunctions . . . . .	3-19
Gear Up Landing . . . . .	3-20
Electrical Power Supply System Malfunctions . . . . .	3-20
Excessive Rate Of Charge . . . . .	3-21
Insufficient Rate Of Charge . . . . .	3-21
Other Emergencies . . . . .	3-22
Windshield Damage . . . . .	3-22



## INTRODUCTION

Section 3 provides checklist and amplified procedures for coping with emergencies that may occur. Emergencies caused by airplane or engine malfunctions are extremely rare if proper preflight inspections and maintenance are practiced. Enroute weather emergencies can be minimized or eliminated by careful flight planning and good judgment when unexpected weather is encountered. However, should an emergency arise, the basic guidelines described in this section should be considered and applied as necessary to correct the problem. Emergency procedures associated with ELT and other optional systems can be found in Section 9.

## AIRSPEEDS FOR EMERGENCY OPERATION

### Engine Failure After Takeoff:

Wing Flaps Up . . . . .	70 KIAS
Wing Flaps Down . . . . .	65 KIAS
Maneuvering Speed:	
2650 Lbs . . . . .	106 KIAS
2250 Lbs . . . . .	98 KIAS
1850 Lbs . . . . .	89 KIAS
Maximum Glide:	
2650 Lbs . . . . .	73 KIAS
2250 Lbs . . . . .	67 KIAS
1850 Lbs . . . . .	61 KIAS
Precautionary Landing With Engine Power . . . . .	65 KIAS
Landing Without Engine Power:	
Wing Flaps Up . . . . .	75 KIAS
Wing Flaps Down . . . . .	65 KIAS

## OPERATIONAL CHECKLISTS

Procedures in the Operational Checklists portion of this section shown in **bold-faced** type are immediate-action items which should be committed to memory.

## ENGINE FAILURES

### ENGINE FAILURE DURING TAKEOFF ROLL

1. **Throttle -- IDLE.**

2. **Brakes -- APPLY.**
3. **Wing Flaps -- RETRACT.**
4. **Mixture -- IDLE CUT-OFF.**
5. **Ignition Switch -- OFF.**
6. **Master Switch -- OFF.**

### ENGINE FAILURE IMMEDIATELY AFTER TAKEOFF

1. **Airspeed -- 70 KIAS (flaps UP).  
65 KIAS (flaps DOWN).**
2. **Mixture -- IDLE CUT-OFF.**
3. **Fuel Selector Valve -- OFF.**
4. **Ignition Switch -- OFF.**
5. **Wing Flaps -- AS REQUIRED (30° recommended).**
6. **Master Switch -- OFF.**

### ENGINE FAILURE DURING FLIGHT (RESTART PROCEDURES)

1. **Airspeed -- 75 KIAS.**
2. **Carburetor Heat -- ON.**
3. **Fuel Selector Valve -- BOTH.**
4. **Mixture -- RICH.**
5. **Auxiliary Fuel Pump -- ON if fuel pressure is below 0.5 PSI.**
6. **Ignition Switch -- BOTH (or START if propeller is stopped).**
7. **Primer -- IN and LOCKED.**

## FORCED LANDINGS

### EMERGENCY LANDING WITHOUT ENGINE POWER

1. **Airspeed -- 75 KIAS (flaps UP).  
65 KIAS (flaps DOWN).**
2. **Mixture -- IDLE CUT-OFF.**
3. **Fuel Selector Valve -- OFF.**
4. **Ignition Switch -- OFF.**
5. **Landing Gear -- DOWN (UP if terrain is rough or soft).**
6. **Wing Flaps -- AS REQUIRED (30° recommended).**
7. **Doors -- UNLATCH PRIOR TO TOUCHDOWN.**
8. **Master Switch -- OFF when landing is assured.**
9. **Touchdown -- SLIGHTLY TAIL LOW.**
10. **Brakes -- APPLY HEAVILY.**

### PRECAUTIONARY LANDING WITH ENGINE POWER

1. **Wing Flaps -- 20°.**

2. Airspeed -- 65 KIAS.
3. Selected Field -- FLY OVER, noting terrain and obstructions, then retract flaps upon reaching a safe altitude and airspeed.
4. Electrical Switches -- OFF.
5. Landing Gear -- DOWN (UP if terrain is rough or soft).
6. Wing Flaps -- 30° (on final approach).
7. Airspeed -- 65 KIAS.
8. Doors -- UNLATCH PRIOR TO TOUCHDOWN.
9. Avionics Power and Master Switches -- OFF.
10. Touchdown -- SLIGHTLY TAIL LOW.
11. Ignition Switch -- OFF.
12. Brakes -- APPLY HEAVILY.

## DITCHING

1. Radio -- TRANSMIT MAYDAY on 121.5 MHz, giving location and intentions and SQUAWK 7700 if transponder is installed.
2. Heavy Objects (in baggage area) -- SECURE OR JETTISON.
3. Landing Gear -- UP.
4. Flaps -- 20° - 30°.
5. Power -- ESTABLISH 300 FT/MIN DESCENT at 60 KIAS.
6. Approach -- High Winds, Heavy Seas -- INTO THE WIND.  
Light Winds, Heavy Swells -- PARALLEL TO SWELLS.

### NOTE

If no power is available, approach at 70 KIAS with flaps up or at 65 KIAS with 10° flaps.

7. Cabin Doors -- UNLATCH.
8. Touchdown -- LEVEL ATTITUDE AT ESTABLISHED DESCENT.
9. Face -- CUSHION at touchdown with folded coat.
10. Airplane -- EVACUATE through cabin doors. If necessary, open windows and flood cabin to equalize pressure so doors can be opened.
11. Life Vests and Raft -- INFLATE.

## FIRES

### DURING START ON GROUND

1. **Cranking** -- CONTINUE, to get a start which would suck the flames and accumulated fuel through the carburetor and into the engine.

If engine starts:

2. Power -- 1700 RPM for a few minutes.
3. Engine -- SHUTDOWN and inspect for damage.

If engine fails to start:

4. **Throttle -- FULL OPEN.**
5. **Mixture -- IDLE CUT-OFF.**
6. **Cranking -- CONTINUE.**
7. Fire Extinguisher -- OBTAIN (have ground attendants obtain if not installed).
8. Engine -- SECURE.
  - a. Master Switch -- OFF.
  - b. Ignition Switch -- OFF.
  - c. Fuel Selector Valve -- OFF.
9. Fire -- EXTINGUISH using fire extinguisher, wool blanket, or dirt.
10. Fire Damage -- INSPECT, repair damage or replace damaged components or wiring before conducting another flight.

### ENGINE FIRE IN FLIGHT

1. **Mixture -- IDLE CUT-OFF.**
2. **Fuel Selector Valve -- OFF.**
3. Master Switch -- OFF.
4. Cabin Heat and Air -- OFF (except overhead vents).
5. Airspeed -- 105 KIAS (If fire is not extinguished, increase glide speed to find an airspeed which will provide an incombustible mixture).
6. Forced Landing -- EXECUTE (as described in Emergency Landing Without Engine Power).

### ELECTRICAL FIRE IN FLIGHT

1. **Master Switch -- OFF.**
2. **Vents/Cabin Air/Heat -- CLOSED.**
3. **Fire Extinguisher -- ACTIVATE (if available).**

#### WARNING

After discharging an extinguisher within a closed cabin, ventilate the cabin.

4. Avionics Power Switch -- OFF.
5. All Other Switches (except ignition switch) -- OFF.

If fire appears out and electrical power is necessary for continuance of flight:

6. Master Switch -- ON.
7. Circuit Breakers -- CHECK for faulty circuit, do not reset.
8. Radio Switches -- OFF.
9. Avionics Power Switch -- ON.
10. Radio/Electrical Switches -- ON one at a time, with delay after each until short circuit is localized.
11. Vents/Cabin Air/Heat -- OPEN when it is ascertained that fire is completely extinguished.

## CABIN FIRE

1. Master Switch -- OFF.
2. Vents/Cabin Air/Heat -- CLOSED (to avoid drafts).
3. Fire Extinguisher -- ACTIVATE (if available).

### WARNING

After discharging an extinguisher within a closed cabin, ventilate the cabin.

4. Land the airplane as soon as possible to inspect for damage.

## WING FIRE

1. Landing/Taxi Light Switches -- OFF.
2. Pitot Heat Switch (if installed) -- OFF.
3. Navigation Light Switch -- OFF.
4. Strobe Light Switch (if installed) -- OFF.

### NOTE

Perform a sideslip to keep the flames away from the fuel tank and cabin, and land as soon as possible using flaps only as required for final approach and touchdown.

## ICING

### INADVERTENT ICING ENCOUNTER

1. Turn pitot heat switch ON (if installed).
2. Turn back or change altitude to obtain an outside air temperature that is less conducive to icing.
3. Pull cabin heat and cabin air controls full out and open defroster

**valves** to obtain maximum defroster airflow.

4. Increase engine speed to minimize ice build-up on propeller blades.
5. Watch for signs of carburetor air filter ice and apply carburetor heat as required. An unexplained loss in manifold pressure could be caused by carburetor ice or air intake filter ice. Lean the mixture if carburetor heat is used continuously.
6. Plan a landing at the nearest airport. With an extremely rapid ice build-up, select a suitable "off airport" landing site.
7. With an ice accumulation of 1/4 inch or more on the wing leading edges, be prepared for significantly higher stall speed.
8. Leave wing flaps retracted. With a severe ice build-up on the horizontal tail, the change in wing wake airflow direction caused by wing flap extension could result in a loss of elevator effectiveness.
9. Open the window and, if practical, scrape ice from a portion of the windshield for visibility in the landing approach.
10. Perform a landing approach using a forward slip, if necessary, for improved visibility.
11. Approach at 80 to 90 KIAS, depending upon the amount of ice accumulation.
12. Perform a landing in level attitude.

### **STATIC SOURCE BLOCKAGE (Erroneous Instrument Reading Suspected)**

1. **Static Pressure Alternate Source Valve (if installed) -- PULL ON.**

#### **NOTE**

In an emergency on airplanes not equipped with an alternate static source, cabin pressure can be supplied to the static pressure instruments by breaking the glass in the face of the vertical speed indicator.

2. Windows -- CLOSED.
3. Airspeed -- Consult appropriate table in Section 5.

## **LANDING GEAR MALFUNCTION PROCEDURES**

### **LANDING GEAR FAILS TO RETRACT**

1. Master Switch -- ON.
2. Landing Gear Lever -- CHECK (lever full up).
3. Landing Gear and Gear Pump Circuit Breakers -- IN.

4. Landing Gear Lever -- RECYCLE.
5. Gear Motor -- CHECK operation (ammeter and noise).

### LANDING GEAR FAILS TO EXTEND

1. Master Switch -- ON.
2. Landing Gear Lever -- DOWN.
3. Landing Gear and Gear Pump Circuit Breakers -- IN.
4. Emergency Hand Pump -- EXTEND HANDLE, and PUMP (perpendicular to handle until resistance becomes heavy -- about 35 cycles).
5. Gear Locked Light -- ON.
6. Gear Unsafe Light -- OFF.
7. Pump Handle -- STOW.

### GEAR UNSAFE LIGHT ILLUMINATES

(GEAR UP selected)

1. Gear Motor -- CHECK audibly for operation.
2. Main Gear --CHECK visually to see if they appear to be retracted.
3. Gear Pump Circuit Breaker -- PULL if gear appears to be retracted but gear motor continues to run and flight is to be continued to a maintenance facility.

(GEAR DOWN selected)

1. Gear Locked Light -- CHECK (If the gear locked light is ON but the gear motor continues to run, PULL the gear pump circuit breaker until just prior to landing; then RESET it. This will prevent overheating the gear motor. If the gear locked light is not illuminated, proceed to the Landing Without Positive Indication of Gear Locking checklist.)

### GEAR UP LANDING

1. Landing Gear Lever -- UP.
2. Landing Gear and Gear Pump Circuit Breakers -- IN.
3. Runway -- SELECT longest hard surface or smooth sod runway available.
4. Wing Flaps -- 30° (on final approach).
5. Airspeed -- 65 KIAS.
6. Doors -- UNLATCH PRIOR TO TOUCHDOWN.
7. Avionics Power and Master Switches -- OFF when landing is assured.
8. Touchdown -- SLIGHTLY TAIL LOW.

9. Mixture -- IDLE CUT-OFF.
10. Ignition Switch -- OFF.
11. Fuel Selector Valve -- OFF.
12. Airplane -- EVACUATE.

### LANDING WITHOUT POSITIVE INDICATION OF GEAR LOCKING

1. Before Landing Check -- COMPLETE.
2. Approach -- NORMAL (full flap).
3. Landing Gear and Gear Pump Circuit Breakers -- IN.
4. Landing -- TAIL LOW as smoothly as possible.
5. Braking -- MINIMUM necessary.
6. Taxi -- SLOWLY.
7. Engine -- SHUTDOWN before inspecting gear.

### LANDING WITH A DEFECTIVE NOSE GEAR (Or Flat Nose Tire)

1. Movable Load -- TRANSFER to baggage area.
2. Passenger -- MOVE to rear seat.
3. Before Landing Checklist -- COMPLETE.
4. Runway -- HARD SURFACE or SMOOTH SOD.
5. Wing Flaps -- 30°
6. Cabin Doors -- UNLATCH PRIOR TO TOUCHDOWN.
7. Avionics Power and Master Switches -- OFF when landing is assured.
8. Land -- SLIGHTLY TAIL LOW.
9. Mixture -- IDLE CUT-OFF.
10. Ignition Switch -- OFF.
11. Fuel Selector Valve -- OFF.
12. Elevator Control -- HOLD NOSE OFF GROUND as long as possible.
13. Airplane -- EVACUATE as soon as it stops.

### LANDING WITH A FLAT MAIN TIRE

1. Approach -- NORMAL (full flap).
2. Touchdown -- GOOD TIRE FIRST, hold airplane off flat tire as long as possible with aileron control.
3. Directional Control -- MAINTAIN using brake on good wheel as required.



## **ELECTRICAL POWER SUPPLY SYSTEM MALFUNCTIONS**

### **AMMETER SHOWS EXCESSIVE RATE OF CHARGE (Full Scale Deflection)**

1. Alternator -- OFF.
2. Alternator Circuit Breaker -- PULL.
3. Nonessential Electrical Equipment -- OFF.
4. Flight -- TERMINATE as soon as practical.

### **LOW-VOLTAGE LIGHT ILLUMINATES DURING FLIGHT (Ammeter Indicates Discharge)**

#### **NOTE**

Illumination of the low-voltage light may occur during low RPM conditions with an electrical load on the system such as during a low RPM taxi. Under these conditions, the light will go out at higher RPM. The master switch need not be recycled since an over-voltage condition has not occurred to de-activate the alternator system.

1. Avionics Power Switch -- OFF.
2. Alternator Circuit Breaker -- CHECK IN.
3. Master Switch -- OFF (both sides).
4. Master Switch -- ON.
5. Low-Voltage Light -- CHECK OFF.
6. Avionics Power Switch -- ON.

If low-voltage light illuminates again:

7. Alternator -- OFF.
8. Nonessential Radio and Electrical Equipment -- OFF.
9. Flight -- TERMINATE as soon as practical.

For Training Purposes Only

## AMPLIFIED PROCEDURES

The following Amplified Procedures elaborate upon information contained in the Operational Checklists portion of this section. These procedures also include information not readily adaptable to a checklist format, and material to which a pilot could not be expected to refer in resolution of a specific emergency.

### ENGINE FAILURE

If an engine failure occurs during the takeoff run, the most important thing to do is stop the airplane on the remaining runway. Those extra items on the checklist will provide added safety after a failure of this type.

Prompt lowering of the nose to maintain airspeed and establish a glide attitude is the first response to an engine failure after takeoff. In most cases, the landing should be planned straight ahead with only small changes in direction to avoid obstructions. Altitude and airspeed are seldom sufficient to execute a 180° gliding turn necessary to return to the runway. The checklist procedures assume that adequate time exists to secure the fuel and ignition systems prior to touchdown.

After an engine failure in flight, the best glide speed as shown in figure 3-1 should be established as quickly as possible. While gliding toward a

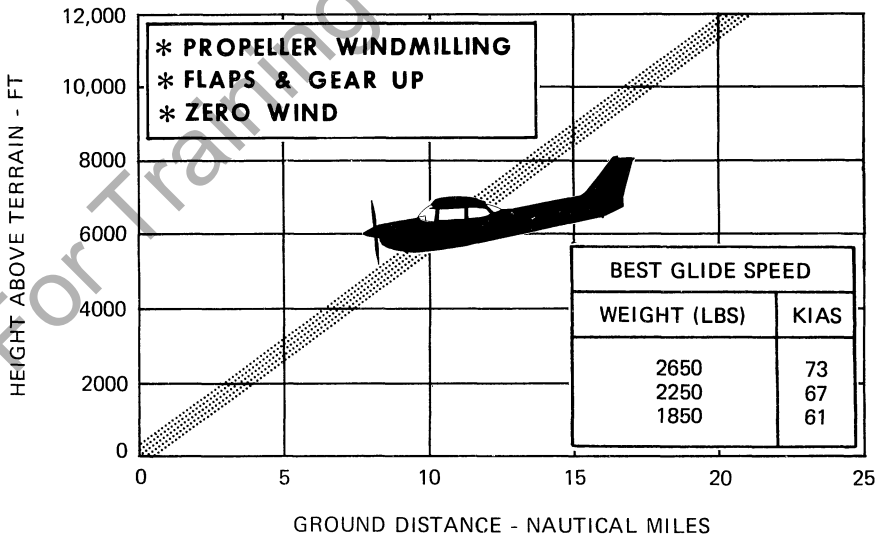

Figure 3-1. Maximum Glide

suitable landing area, an effort should be made to identify the cause of the failure. If time permits, an engine restart should be attempted as shown in the checklist. If the engine cannot be restarted, a forced landing without power must be completed.

## FORCED LANDINGS

If all attempts to restart the engine fail and a forced landing is imminent, select a suitable field and prepare for the landing as discussed in the checklist for Emergency Landing Without Engine Power.

Before attempting an "off airport" landing with engine power available, one should fly over the landing area at a safe but low altitude to inspect the terrain for obstructions and surface conditions, proceeding as discussed under the Precautionary Landing With Engine Power checklist.

Prepare for ditching by securing or jettisoning heavy objects located in the baggage area and collect folded coats for protection of occupants' face at touchdown. Transmit Mayday message on 121.5 MHz giving location and intentions and squawk 7700 if a transponder is installed. Avoid a landing flare because of difficulty in judging height over a water surface.

In a forced landing situation, do not turn off the avionics power and master switches until a landing is assured. Premature deactivation of the switches will disable the encoding altimeter and airplane electrical systems.

## LANDING WITHOUT ELEVATOR CONTROL

With airspeed below 130 KIAS, simultaneously select gear down and 10° flaps. Trim for horizontal flight with an airspeed of approximately 70 KIAS by using throttle and elevator trim control. Then **do not change the elevator trim control setting**; control the glide angle by adjusting power exclusively.

At flareout, the nose-down moment resulting from power reduction is an adverse factor and the airplane may hit on the nose wheel. Consequently, at flareout, the elevator trim control should be adjusted toward the nose-up position and the power adjusted so that the airplane will rotate to the horizontal attitude for touchdown. Close the throttle at touchdown.

## FIRES

Although engine fires are extremely rare in flight, the steps of the appropriate checklist should be followed if one is encountered. After completion of this procedure, execute a forced landing. Do not attempt to

restart the engine.

The initial indication of an electrical fire is usually the odor of burning insulation. The checklist for this problem should result in elimination of the fire.

## **EMERGENCY OPERATION IN CLOUDS (Vacuum System Failure)**

In the event of a vacuum system failure during flight, the directional indicator and attitude indicator will be disabled, and the pilot will have to rely on the turn coordinator if he inadvertently flies into clouds. The following instructions assume that only the electrically-powered turn coordinator is operative, and that the pilot is not completely proficient in instrument flying.

### **EXECUTING A 180° TURN IN CLOUDS**

Upon inadvertently entering the clouds, an immediate plan should be made to turn back as follows:

1. Note the compass heading.
2. Note the time of the minute hand and observe the position of the sweep second hand on the clock.
3. When the sweep second hand indicates the nearest half-minute, initiate a standard rate left turn, holding the turn coordinator symbolic airplane wing opposite the lower left index mark for 60 seconds. Then roll back to level flight by leveling the miniature airplane.
4. Check accuracy of the turn by observing the compass heading which should be the reciprocal of the original heading.
5. If necessary, adjust heading primarily with skidding motions rather than rolling motions so that the compass will read more accurately.
6. Maintain altitude and airspeed by cautious application of elevator control. Avoid overcontrolling by keeping the hands off the control wheel as much as possible and steering only with rudder.

### **EMERGENCY DESCENT THROUGH CLOUDS**

If conditions preclude reestablishment of VFR flight by a 180° turn, a descent through a cloud deck to VFR conditions may be appropriate. If possible, obtain radio clearance for an emergency descent through clouds. To guard against a spiral dive, choose an easterly or westerly heading to minimize compass card swings due to changing bank angles. In addition, keep hands off the control wheel and steer a straight course with rudder

control by monitoring the turn coordinator. Occasionally check the compass heading and make minor corrections to hold an approximate course. Before descending into the clouds, set up a stabilized let-down condition as follows:

1. Extend landing gear.
2. Apply full rich mixture.
3. Apply full carburetor heat.
4. Reduce power to set up a 500 to 800 ft/min rate of descent.
5. Adjust the elevator and rudder trim control wheels for a stabilized descent at 80 KIAS.
6. Keep hands off control wheel.
7. Monitor turn coordinator and make corrections by rudder alone.
8. Adjust rudder trim to relieve unbalanced rudder force, if present.
9. Check trend of compass card movement and make cautious corrections with rudder to stop turn.
10. Upon breaking out of clouds, resume normal cruising flight.

## RECOVERY FROM A SPIRAL DIVE

If a spiral is encountered, proceed as follows:

1. Close the throttle.
2. Stop the turn by using coordinated aileron and rudder control to align the symbolic airplane in the turn coordinator with the horizon reference line.
3. Cautiously apply elevator back pressure to slowly reduce the indicated airspeed to 80 KIAS.
4. Adjust the elevator trim control to maintain an 80 KIAS glide.
5. Keep hands off the control wheel, using rudder control to hold a straight heading. Use rudder trim to relieve unbalanced rudder force, if present.
6. Apply carburetor heat.
7. Clear engine occasionally, but avoid using enough power to disturb the trimmed glide.
8. Upon breaking out of clouds, resume normal cruising flight.

## INADVERTENT FLIGHT INTO ICING CONDITIONS

Flight into icing conditions is prohibited. An inadvertent encounter with these conditions can best be handled using the checklist procedures. The best procedure, of course, is to turn back or change altitude to escape icing conditions.

## STATIC SOURCE BLOCKED

If erroneous readings of the static source instruments (airspeed, altimeter and vertical speed) are suspected, the alternate static source valve should be pulled on, thereby supplying static pressure to these instruments from the cabin. Cabin pressures will vary with open ventilators or windows and with airspeed. To avoid the possibility of large errors, the windows should not be open when using the alternate static source.

### NOTE

In an emergency on airplanes not equipped with an alternate static source, cabin pressure can be supplied to the static pressure instruments by breaking the glass in the face of the vertical speed indicator.

A calibration table is provided in Section 5 to illustrate the effect of the alternate static source on indicated airspeeds. With the windows closed and the heater and defroster full on, the airspeed indicator may typically read as much as 3 knots slower and the altimeter 35 feet lower in cruise. If the alternate static source must be used for landing, the normal indicated approach speed may be used since the indicated airspeed variations in this configuration are 2 knots or less.

## SPINS

Intentional spins are prohibited in this airplane. Should an inadvertent spin occur, the following recovery procedure should be used:

1. RETARD THROTTLE TO IDLE POSITION.
2. PLACE AILERONS IN NEUTRAL POSITION.
3. APPLY AND **HOLD FULL** RUDDER OPPOSITE TO THE DIRECTION OF ROTATION.
4. JUST **AFTER** THE RUDDER REACHES THE STOP, MOVE THE WHEEL **BRISKLY** FORWARD FAR ENOUGH TO BREAK THE STALL. Full down elevator may be required at aft center of gravity loadings to assure optimum recoveries.
5. **HOLD** THESE CONTROL INPUTS UNTIL ROTATION STOPS. Premature relaxation of the control inputs may extend the recovery.
6. AS ROTATION STOPS, NEUTRALIZE RUDDER, AND MAKE A SMOOTH RECOVERY FROM THE RESULTING DIVE.

### NOTE

If disorientation precludes a visual determination of the

direction of rotation, the symbolic airplane in the turn coordinator may be referred to for this information.

## **ROUGH ENGINE OPERATION OR LOSS OF POWER**

### **CARBURETOR ICING**

An unexplained drop in manifold pressure and eventual engine roughness may result from the formation of carburetor ice. To clear the ice, apply full throttle and pull the carburetor heat knob full out until the engine runs smoothly; then remove carburetor heat and readjust the throttle. If conditions require the continued use of carburetor heat in cruise flight, use the minimum amount of heat necessary to prevent ice from forming and lean the mixture for smoothest engine operation.

### **SPARK PLUG FOULING**

A slight engine roughness in flight may be caused by one or more spark plugs becoming fouled by carbon or lead deposits. This may be verified by turning the ignition switch momentarily from BOTH to either L or R position. An obvious power loss in single ignition operation is evidence of spark plug or magneto trouble. Assuming that spark plugs are the more likely cause, lean the mixture to the recommended lean setting for cruising flight. If the problem does not clear up in several minutes, determine if a richer mixture setting will produce smoother operation. If not, proceed to the nearest airport for repairs using the BOTH position of the ignition switch unless extreme roughness dictates the use of a single ignition position.

### **MAGNETO MALFUNCTION**

A sudden engine roughness or misfiring is usually evidence of magneto problems. Switching from BOTH to either L or R ignition switch position will identify which magneto is malfunctioning. Select different power settings and enrichen the mixture to determine if continued operation on BOTH magnetos is practicable. If not, switch to the good magneto and proceed to the nearest airport for repairs.

### **ENGINE-DRIVEN FUEL PUMP FAILURE**

In the event of an engine-driven fuel pump failure, gravity flow will provide sufficient fuel flow for level or descending flight. However, in a climbing attitude or anytime the fuel pressure drops to 0.5 PSI, the auxiliary fuel pump should be turned on.



## LOW OIL PRESSURE

If low oil pressure is accompanied by normal oil temperature, there is a possibility the oil pressure gage or relief valve is malfunctioning. A leak in the line to the gage is not necessarily cause for an immediate precautionary landing because an orifice in this line will prevent a sudden loss of oil from the engine sump. However, a landing at the nearest airport would be advisable to inspect the source of trouble.

If a total loss of oil pressure is accompanied by a rise in oil temperature, there is good reason to suspect an engine failure is imminent. Reduce engine power immediately and select a suitable forced landing field. Use only the minimum power required to reach the desired touchdown spot.

## LANDING GEAR MALFUNCTION PROCEDURES

In the event of possible landing gear retraction or extension malfunctions, there are several general checks that should be made prior to initiating the steps outlined in the following paragraphs.

In analyzing a landing gear malfunction, first check that the master switch is ON and the LDG GEAR and GEAR PUMP circuit breakers are in; reset, if necessary. Also, check both landing gear position indicator lights for operation by "pressing-to-test" the light units and rotating them at the same time to check for open dimming shutters. A burned-out bulb can be replaced in flight by using the bulb from a post light or from the remaining gear position indicator light.

### RETRACTION MALFUNCTIONS

If the landing gear fails to retract normally, attempt to recycle the landing gear. Place the landing gear lever in the GEAR DOWN position. When the GEAR LOCKED light illuminates, reposition the gear lever in the GEAR UP position for another retraction attempt. If the GEAR UNSAFE indicator light remains illuminated, the flight may be continued to an airport having maintenance facilities. If gear motor operation is audible after a period of one minute following gear up selection, pull the GEAR PUMP circuit breaker switch to prevent the electric motor from overheating. In this event, remember to re-engage the circuit breaker just prior to gear extension. Intermittent gear motor operation may also be detected by momentary fluctuations of the ammeter needle, and illumination of the GEAR UNSAFE light.

### EXTENSION MALFUNCTIONS

Normal landing gear extension time is approximately 5 seconds. If the

landing gear will not extend normally, perform the general checks of circuit breakers and master switch and repeat the normal extension procedures at a reduced airspeed of 100 KIAS. The landing gear lever must be in the down position with the detent engaged. If efforts to extend and lock the gear through the normal landing gear system fail, the gear can be manually extended (as long as hydraulic system fluid has not been completely lost) by use of the emergency hand pump. The hand pump is located between the front seats. A checklist is provided for step-by-step instructions for a manual gear extension.

It is possible to have both the GEAR LOCKED and GEAR UNSAFE indicator lights illuminated at the same time. This indicates that the gear is down and locked but because of a pressure switch malfunction or a malfunctioning hydraulic pump, the pump motor is still running. If this should occur, pull the gear pump circuit breaker to prevent the electric motor from overheating. In this event, remember to re-engage the circuit breaker just prior to landing.

### **GEAR UP LANDINGS**

If the landing gear remains retracted or is only partially extended, and all efforts to fully extend it (including manual extension) have failed, plan a wheels-up landing. In preparation for landing, reposition the landing gear lever to GEAR UP and push the LDG GEAR and GEAR PUMP circuit breakers in to allow the landing gear to swing into the gear wells at touchdown. Then proceed in accordance with the checklist.

## **ELECTRICAL POWER SUPPLY SYSTEM MALFUNCTIONS**

Malfunctions in the electrical power supply system can be detected by periodic monitoring of the ammeter and low-voltage warning light; however, the cause of these malfunctions is usually difficult to determine. A broken alternator drive belt or wiring is most likely the cause of alternator failures, although other factors could cause the problem. A defective alternator control unit can also cause malfunctions. Problems of this nature constitute an electrical emergency and should be dealt with immediately. Electrical power malfunctions usually fall into two categories: excessive rate of charge and insufficient rate of charge. The paragraphs below describe the recommended remedy for each situation.

## EXCESSIVE RATE OF CHARGE

After engine starting and heavy electrical usage at low engine speeds (such as extended taxiing) the battery condition will be low enough to accept above normal charging during the initial part of a flight. However, after thirty minutes of cruising flight, the ammeter should be indicating less than two needle widths of charging current. If the charging rate were to remain above this value on a long flight, the battery would overheat and evaporate the electrolyte at an excessive rate.

Electronic components in the electrical system can be adversely affected by higher than normal voltage. The alternator control unit includes an over-voltage sensor which normally will automatically shut down the alternator if the charge voltage reaches approximately 31.5 volts. If the over-voltage sensor malfunctions, as evidenced by an excessive rate of charge shown on the ammeter, the alternator should be turned off, alternator circuit breaker pulled, nonessential electrical equipment turned off and the flight terminated as soon as practical.

## INSUFFICIENT RATE OF CHARGE

### NOTE

Illumination of the low-voltage light and ammeter discharge indications may occur during low RPM conditions with an electrical load on the system, such as during a low RPM taxi. Under these conditions, the light will go out at higher RPM. The master switch need not be recycled since an over-voltage condition has not occurred to de-activate the alternator system.

If the over-voltage sensor should shut down the alternator or if the alternator output is low, a discharge rate will be shown on the ammeter followed by illumination of the low-voltage warning light. Since this may be a "nuisance" trip-out, an attempt should be made to reactivate the alternator system. To do this, turn the avionics power switch off, check that the alternator circuit breaker is in, then turn both sides of the master switch off and then on again. If the problem no longer exists, normal alternator charging will resume and the low-voltage light will go off. The avionics power switch may then be turned back on. If the light illuminates again, a malfunction is confirmed. In this event, the flight should be terminated and/or the current drain on the battery minimized because the battery can supply the electrical system for only a limited period of time. Battery power must be conserved for later operation of the landing gear and wing flaps and, if the emergency occurs at night, for possible use of the landing lights during landing.

## **OTHER EMERGENCIES**

### **WINDSHIELD DAMAGE**

If a bird strike or other incident should damage the windshield in flight to the point of creating an opening, a significant loss in performance may be expected. This loss may be minimized in some cases (depending on amount of damage, altitude, etc.) by opening the side windows while the airplane is maneuvered for a landing at the nearest airport.

If airplane performance or other adverse conditions preclude landing at an airport, prepare for an "off airport" landing in accordance with the Precautionary Landing With Engine Power or Ditching checklist.

# SECTION 4

# NORMAL PROCEDURES

## TABLE OF CONTENTS

	Page
Introduction . . . . .	4-3
Speeds For Normal Operation . . . . .	4-3

### CHECKLIST PROCEDURES

Preflight Inspection . . . . .	4-5
Cabin . . . . .	4-5
Empennage . . . . .	4-5
Right Wing, Trailing Edge . . . . .	4-5
Right Wing . . . . .	4-6
Nose . . . . .	4-6
Left Wing . . . . .	4-6
Left Wing, Leading Edge . . . . .	4-7
Left Wing, Trailing Edge . . . . .	4-7
Before Starting Engine . . . . .	4-7
Starting Engine . . . . .	4-7
Before Takeoff . . . . .	4-8
Takeoff . . . . .	4-9
Normal Takeoff . . . . .	4-9
Short Field Takeoff . . . . .	4-9
Enroute Climb . . . . .	4-10
Normal Climb . . . . .	4-10
Maximum Performance Climb . . . . .	4-10
Cruise . . . . .	4-10
Descent . . . . .	4-10
Before Landing . . . . .	4-11
Landing . . . . .	4-11
Normal Landing . . . . .	4-11
Short Field Landing . . . . .	4-11
Balked Landing . . . . .	4-11
After Landing . . . . .	4-12
Securing Airplane . . . . .	4-12

## TABLE OF CONTENTS (Continued)

	Page
<b>AMPLIFIED PROCEDURES</b>	
Preflight Inspection . . . . .	4-13
Starting Engine . . . . .	4-14
Taxiing . . . . .	4-16
Before Takeoff . . . . .	4-16
Warm-Up . . . . .	4-16
Magneto Check . . . . .	4-16
Alternator Check . . . . .	4-16
Takeoff . . . . .	4-17
Power Check . . . . .	4-17
Wing Flap Settings . . . . .	4-17
Crosswind Takeoff . . . . .	4-17
Landing Gear Retraction . . . . .	4-18
Enroute Climb . . . . .	4-18
Cruise . . . . .	4-18
Leaning With A Cessna Economy Mixture Indicator (EGT) . . . . .	4-20
Stalls . . . . .	4-21
Before Landing . . . . .	4-21
Landing . . . . .	4-21
Normal Landing . . . . .	4-21
Short Field Landing . . . . .	4-22
Crosswind Landing . . . . .	4-22
Balked Landing . . . . .	4-22
Cold Weather Operation . . . . .	4-22
Starting . . . . .	4-23
Operation . . . . .	4-25
Hot Weather Operation . . . . .	4-25
Noise Characteristics . . . . .	4-25

## INTRODUCTION

Section 4 provides checklist and amplified procedures for the conduct of normal operation. Normal procedures associated with optional systems can be found in Section 9.

## SPEEDS FOR NORMAL OPERATION

Unless otherwise noted, the following speeds are based on a maximum weight of 2650 pounds and may be used for any lesser weight. However, to achieve the performance specified in Section 5 for takeoff distance, the speed appropriate to the particular weight must be used.

### Takeoff:

Normal Climb Out . . . . .	70-80 KIAS
Short Field Takeoff, Flaps 0°, Speed at 50 Feet . . . . .	63 KIAS

### Enroute Climb, Flaps and Gear Up:

Normal . . . . .	85-95 KIAS
Best Rate of Climb, Sea Level . . . . .	84 KIAS
Best Rate of Climb, 10,000 Feet . . . . .	77 KIAS
Best Angle of Climb, Sea Level . . . . .	67 KIAS
Best Angle of Climb, 10,000 Feet . . . . .	68 KIAS

### Landing Approach:

Normal Approach, Flaps Up . . . . .	70-80 KIAS
Normal Approach, Flaps 30° . . . . .	60-70 KIAS
Short Field Approach, Flaps 30° . . . . .	63 KIAS

### Balked Landing:

Maximum Power, Flaps 20° . . . . .	55 KIAS
------------------------------------	---------

### Maximum Recommended Turbulent Air Penetration Speed:

2650 Lbs . . . . .	106 KIAS
2250 Lbs . . . . .	98 KIAS
1850 Lbs . . . . .	89 KIAS

### Maximum Demonstrated Crosswind Velocity:

Takeoff or Landing . . . . .	15 KNOTS
------------------------------	----------

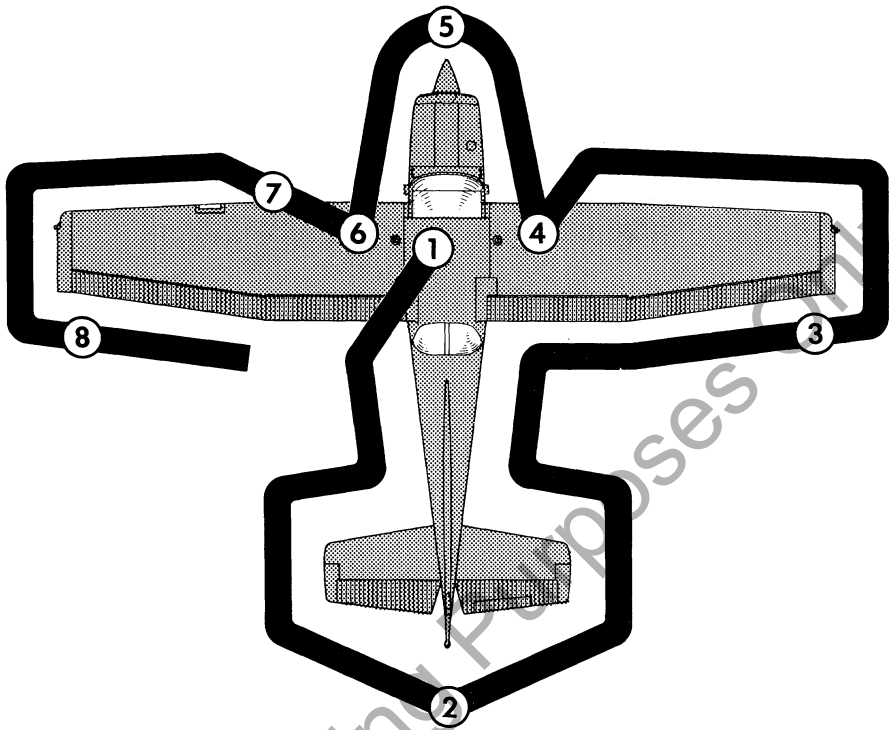

NOTE

Visually check airplane for general condition during walk-around inspection. Use of the refueling steps and assist handles (if installed) will simplify access to the upper wing surfaces for visual checks and refueling operations. In cold weather, remove even small accumulations of frost, ice or snow from wing, tail and control surfaces. Also, make sure that control surfaces contain no internal accumulations of ice or debris. Prior to flight, check that pitot heater (if installed) is warm to touch within 30 seconds with battery and pitot heat switches on. If a night flight is planned, check operation of all lights, and make sure a flashlight is available.

Figure 4-1. Preflight Inspection



## CHECKLIST PROCEDURES

### PREFLIGHT INSPECTION

#### ① CABIN

1. Pilot's Operating Handbook -- AVAILABLE IN THE AIRPLANE.
2. Parking Brake -- SET.
3. Control Wheel Lock -- REMOVE.
4. Avionics Power Switch -- OFF.
5. Ignition Switch -- OFF.
6. Landing Gear Lever -- DOWN.
7. Master Switch -- ON.

#### WARNING

When turning on the master switch, using an external power source, or pulling the propeller through by hand, treat the propeller as if the ignition switch were on. Do not stand, nor allow anyone else to stand, within the arc of the propeller, since a loose or broken wire, or a component malfunction, could cause the propeller to rotate.

8. Fuel Quantity Indicators -- CHECK QUANTITY.
9. Low-Vacuum Warning Light -- CHECK ON.
10. Landing Gear Position Indicator Light (green) -- ILLUMINATED.
11. Avionics Cooling Fan -- CHECK AUDIBLY FOR OPERATION.
12. Master Switch -- OFF.
13. Static Pressure Alternate Source Valve (if installed) -- OFF.
14. Fuel Selector Valve -- BOTH.
15. Baggage Door -- CHECK for security.

#### ② EMPENNAGE

1. Left Main Gear Wheel Well -- CHECK for cleanliness.
2. Rudder Gust Lock -- REMOVE.
3. Tail Tie-Down -- DISCONNECT.
4. Control Surfaces -- CHECK freedom of movement and security.
5. Right Main Gear Wheel Well -- CHECK for cleanliness.

#### ③ RIGHT WING Trailing Edge

1. Aileron -- CHECK freedom of movement and security.

#### ④ RIGHT WING

1. Wing Tie-Down -- DISCONNECT.
2. Main Wheel Tire -- CHECK for proper inflation and condition.
3. Fuel Tank Sump Quick-Drain Valve -- DRAIN fuel (using sampler cup) to check for water, sediment, and proper fuel grade before first flight of day and after each refueling. If water is observed, take further samples until there is no evidence of water contamination.
4. Fuel Selector Quick-Drain Valve (on bottom of fuselage) -- DRAIN fuel (using sampler cup) to check for water, sediment, and proper fuel grade before first flight of day and after each refueling. If water is observed, take further samples until there is no evidence of water contamination.
5. Fuel Quantity -- CHECK VISUALLY for desired level.
6. Fuel Filler Cap -- SECURE and vent unobstructed.

#### ⑤ NOSE

1. Static Source Openings (both sides of fuselage) -- CHECK for stoppage.
2. Engine Oil Dipstick/Filler Cap -- CHECK oil level, then check dipstick/filler cap SECURE. Do not operate with less than five quarts. Fill to eight quarts for extended flight.
3. Propeller and Spinner -- CHECK for nicks and security, and oil leaks.
4. Cooling Air Inlets -- CLEAR of obstructions.
5. Nose Gear Doors -- CHECK for security.
6. Nose Wheel Tire, Strut and Wheel Well -- CHECK tire and strut for proper inflation and wheel well for condition and cleanliness.
7. Nose Tie-Down -- DISCONNECT.
8. Fuel Strainer Quick-Drain Valve (on lower left side of engine cowling) -- DRAIN fuel (using sampler cup) to clear strainer of possible water and sediment before first flight of day and after each refueling. If water is observed, the fuel system may contain additional water, and further draining of the system at the strainer, fuel tank sumps, and fuel selector quick-drain valve must be accomplished.

#### ⑥ LEFT WING

1. Fuel Quantity -- CHECK VISUALLY for desired level.
2. Fuel Filler Cap -- SECURE.
3. Fuel Tank Sump Quick-Drain Valve -- DRAIN fuel (using sampler cup) to check for water, sediment, and proper fuel grade before first flight of day and after each refueling. If water is observed, take further samples until there is no evidence of water contamination.

tion.

4. Main Wheel Tire -- CHECK for proper inflation and condition.

### ⑦ LEFT WING Leading Edge

1. Pitot Tube Cover -- REMOVE and check opening for stoppage.
2. Fuel Tank Vent Opening -- CHECK for stoppage.
3. Stall Warning Vane -- CHECK for freedom of movement. While master switch is turned ON, horn should sound when vane is pushed upward.
4. Wing Tie-Down -- DISCONNECT.
5. Landing Lights -- CHECK for condition and cleanliness of cover.

### ⑧ LEFT WING Trailing Edge

1. Aileron -- CHECK for freedom of movement and security.

## BEFORE STARTING ENGINE

1. Preflight Inspection -- COMPLETE.
2. Passenger Briefing -- COMPLETE.
3. Seats, Seat Belts, Shoulder Harnesses -- ADJUST and LOCK.
4. Brakes -- TEST and SET.
5. Avionics Power Switch -- OFF.

### CAUTION

The avionics power switch must be OFF during engine start to prevent possible damage to avionics.

6. Circuit Breakers -- CHECK IN.
7. Electrical Equipment -- OFF.
8. Landing Gear Lever -- DOWN.
9. Autopilot (if installed) -- OFF.
10. Cowl Flaps -- OPEN (move lever out of locking hole to reposition).
11. Fuel Selector Valve -- BOTH.

## STARTING ENGINE

1. Carburetor Heat -- COLD.
2. Propeller -- HIGH RPM.
3. Mixture -- RICH.
4. Propeller Area -- CLEAR.

5. Master Switch -- ON.
6. Throttle -- PUMP once or twice; leave open 1/4 inch. If engine is hot, turn auxiliary fuel pump ON during start.
7. Ignition Switch -- START (release when engine starts).
8. Oil Pressure -- CHECK.
9. Starter -- CHECK DISENGAGED (if starter were to remain engaged, ammeter would indicate full scale charge with engine running at 1000 RPM).
10. Avionics Power Switch -- ON.
11. Navigation Lights and Flashing Beacon -- ON as required.
12. Radios -- ON.

## BEFORE TAKEOFF

1. Parking Brake -- SET.
2. Seats, Seat Belts, Shoulder Harnesses -- CHECK SECURE.
3. Cabin Doors -- CLOSED and LOCKED.
4. Flight Controls -- FREE and CORRECT.
5. Flight Instruments -- CHECK and SET.
6. Fuel Quantity -- CHECK.
7. Auxiliary Fuel Pump -- ON (check for rise in fuel pressure), then OFF.

### NOTE

In flight, gravity feed will normally supply satisfactory fuel flow if the engine-driven fuel pump should fail. However, if a fuel pump failure causes the fuel pressure to drop below 0.5 PSI, use the auxiliary fuel pump to assure proper engine operation.

8. Mixture -- RICH.
9. Fuel Selector Valve -- RECHECK BOTH.
10. Elevator and Rudder Trim -- SET for takeoff.
11. Throttle -- 1800 RPM.
  - a. Magnetos -- CHECK (RPM drop should not exceed 150 RPM on either magneto or 50 RPM differential between magnetos. If RPM drop is excessive, lean to smooth operation and recheck).
  - b. Carburetor Heat -- CHECK (for RPM drop).
  - c. Propeller -- CYCLE from high to low RPM; return to high RPM (full in).
  - d. Mixture -- RICH (below 3000 feet).
  - e. Suction Gage -- CHECK.
  - f. Engine Instruments and Ammeter -- CHECK.
12. Throttle -- 1000 RPM or less.
13. Throttle Friction Lock -- ADJUST.

14. Strobe Lights (if installed) -- AS DESIRED.
15. Radios and Avionics -- SET.
16. Autopilot (if installed) -- OFF.
17. Wing Flaps -- SET for takeoff (see Takeoff checklists).
18. Parking Brake -- RELEASE.

## TAKEOFF

### NORMAL TAKEOFF

1. Wing Flaps -- 0°.
2. Carburetor Heat -- COLD.
3. Power -- FULL THROTTLE and 2700 RPM.
4. Mixture -- RICH (mixture may be leaned above 3000 feet to obtain maximum power).
5. Elevator Control -- LIFT NOSE WHEEL at 55 KIAS.

#### NOTE

When the nose wheel is lifted, the gear motor may normally run 1-2 seconds (accompanied by momentary illumination of GEAR UNSAFE light) to restore hydraulic pressure.

6. Climb Speed -- 70-80 KIAS.
7. Brakes -- APPLY momentarily when airborne.
8. Landing Gear -- RETRACT in climb out.

### SHORT FIELD TAKEOFF

1. Wing Flaps -- 0°.
2. Carburetor Heat -- COLD.
3. Brakes -- APPLY.
4. Power -- FULL THROTTLE and 2700 RPM.
5. Mixture -- RICH (LEAN above 3000 feet to obtain maximum power).
6. Brakes -- RELEASE.
7. Elevator Control -- MAINTAIN SLIGHTLY TAIL-LOW ATTITUDE.
8. Climb Speed -- 63 KIAS until all obstacles are cleared.
9. Landing Gear -- RETRACT after obstacles are cleared.

## ENROUTE CLIMB

### NORMAL CLIMB

1. Airspeed -- 85-95 KIAS.
2. Power -- 25 INCHES Hg and 2500 RPM.
3. Fuel Selector Valve -- BOTH.
4. Mixture -- FULL RICH (mixture may be leaned above 3000 feet).
5. Cowl Flaps -- OPEN as required.

### MAXIMUM PERFORMANCE CLIMB

1. Airspeed -- 84 KIAS at sea level to 77 KIAS at 10,000 feet.
2. Power -- FULL THROTTLE and 2700 RPM.
3. Fuel Selector Valve -- BOTH.
4. Mixture -- FULL RICH (mixture may be leaned above 3000 feet).
5. Cowl Flaps -- FULL OPEN.

## CRUISE

1. Power -- 15-25 INCHES Hg, 2100-2700 RPM.
2. Elevator and Rudder Trim -- ADJUST.
3. Mixture -- LEAN.
4. Cowl Flaps -- CLOSED.

## DESCENT

1. Fuel Selector Valve -- BOTH.
2. Power -- AS DESIRED.
3. Mixture -- ENRICHEN as required.
4. Carburetor Heat -- FULL HEAT AS REQUIRED to prevent carburetor icing.
5. Cowl Flaps -- CLOSED.
6. Wing Flaps -- AS DESIRED (0° - 10° below 130 KIAS, 10° - 30° below 100 KIAS).

### NOTE

The landing gear may be extended below 140 KIAS to increase the rate of descent.

## BEFORE LANDING

1. Seats, Seat Belts, Shoulder Harnesses -- SECURE.
2. Fuel Selector Valve -- BOTH.
3. Landing Gear -- DOWN (below 140 KIAS).
4. Landing Gear -- CHECK (observe main gear down and green indicator light illuminated).
5. Mixture -- RICH.
6. Propeller -- HIGH RPM.
7. Carburetor Heat -- ON (apply full heat before closing throttle).
8. Autopilot (if installed) -- OFF.

## LANDING

### NORMAL LANDING

1. Airspeed -- 70-80 KIAS (flaps UP).
2. Wing Flaps -- AS DESIRED (0°- 10° below 130 KIAS, 10°-30° below 100 KIAS).
3. Airspeed -- 60-70 KIAS (flaps DOWN).
4. Trim -- ADJUST.
5. Touchdown -- MAIN WHEELS FIRST.
6. Landing Roll -- LOWER NOSE WHEEL GENTLY.
7. Braking -- MINIMUM REQUIRED.

### SHORT FIELD LANDING

1. Airspeed -- 70-80 KIAS (flaps UP).
2. Wing Flaps -- 30° (below 100 KIAS).
3. Airspeed -- MAINTAIN 63 KIAS.
4. Trim -- ADJUST.
5. Power -- REDUCE to idle as obstacle is cleared.
6. Touchdown -- MAIN WHEELS FIRST.
7. Brakes -- APPLY HEAVILY.
8. Wing Flaps -- RETRACT for maximum brake effectiveness.

### BALKED LANDING

1. Power -- FULL THROTTLE and 2700 RPM.
2. Carburetor Heat -- COLD.
3. Wing Flaps -- RETRACT to 20°.
4. Climb Speed -- 55 KIAS.
5. Wing Flaps -- RETRACT slowly after reaching 65 KIAS.
6. Cowl Flaps -- OPEN.

## AFTER LANDING

1. Carburetor Heat -- COLD.
2. Wing Flaps -- UP.
3. Cowl Flaps -- OPEN.

## SECURING AIRPLANE

1. Parking Brake -- SET.
2. Throttle -- 1000 RPM.
3. Avionics Power Switch -- OFF.
4. Electrical Equipment -- OFF.
5. Mixture -- IDLE CUT-OFF (pulled full out).
6. Throttle -- CLOSE as RPM drops.
7. Ignition Switch -- OFF.
8. Master Switch -- OFF.
9. Control Lock -- INSTALL.
10. Cowl Flaps -- CLOSE.

For Training Purposes Only



## AMPLIFIED PROCEDURES

### PREFLIGHT INSPECTION

The Preflight Inspection, described in figure 4-1 and adjacent checklist, is recommended for the first flight of the day. Inspection procedures for subsequent flights are normally limited to brief checks of control surface hinges, fuel and oil quantity, and security of fuel and oil filler caps and draining of the fuel strainer, fuel tank sumps, and fuel selector valve. If the airplane has been in extended storage, has had recent major maintenance, or has been operated from marginal airports, a more extensive exterior inspection is recommended.

After major maintenance has been performed, the flight and trim tab controls should be double-checked for free and correct movement and security. The security of all inspection plates on the airplane should be checked following periodic inspections. If the airplane has been waxed or polished, check the external static pressure source holes for stoppage.

If the airplane has been exposed to much ground handling in a crowded hangar, it should be checked for dents and scratches on wings, fuselage, and tail surfaces, as well as damage to navigation and anti-collision lights, and avionics antennas.

Outside storage for long periods may result in dust and dirt accumulation on the induction air filter, obstructions in airspeed system lines, and condensation in fuel tanks. If any water is detected in the fuel system, the fuel tank sump quick-drain valves, fuel selector quick-drain valve, and fuel strainer should all be thoroughly drained until there is no evidence of water or sediment contamination. Outside storage in windy or gusty areas, or tie-down adjacent to taxiing airplanes, calls for special attention to control surface stops, hinges, and brackets to detect the presence of wind damage.

If the airplane has been operated from muddy fields or in snow or slush, check the main and nose gear wheel wells for obstructions and cleanliness. Operation from a gravel or cinder field will require extra attention to propeller tips and abrasion on leading edges of the horizontal tail. Stone damage to the propeller can seriously reduce the fatigue life of the blades.

Airplanes that are operated from rough fields, especially at high altitudes, are subjected to abnormal landing gear abuse. Frequently check all components of the landing gear, shock strut, tires, and brakes. If the shock strut is insufficiently extended, undue landing and taxi loads will be subjected on the airplane structure.

To prevent loss of fuel in flight, make sure the fuel tank filler caps are tightly sealed after any fuel system check or servicing. Fuel system vents should also be inspected for obstructions, ice or water, especially after exposure to cold, wet weather.

## STARTING ENGINE

Ordinarily the engine starts easily with one or two pumps of the throttle in warm temperatures with the mixture full rich. If the engine is hot, turn the auxiliary fuel pump switch ON just prior to and during engine cranking to suppress possible vapor in the fuel line. Turn the auxiliary fuel pump switch OFF after the engine starts. In cooler weather, use of the primer will facilitate engine starting.

### NOTE

Additional details concerning cold weather starting and operation may be found under COLD WEATHER OPERATION paragraphs in this section.

Weak intermittent firing followed by puffs of black smoke from the exhaust stack indicates overpriming or flooding. Excess fuel can be cleared from the combustion chambers by the following procedure: Set the mixture control full lean and the throttle full open; then crank the engine through several revolutions with the starter. Repeat the starting procedure without any additional priming.

If the engine is underprimed (most likely in cold weather with a cold engine) it will not fire at all. Additional priming will be necessary for the next starting attempt.

If prolonged cranking is necessary, allow the starter motor to cool at frequent intervals, since excessive heat may damage the armature.

After starting, if the oil gage does not begin to show pressure within 30 seconds in the summertime and about twice that long in very cold weather, stop engine and investigate. Lack of oil pressure can cause serious engine damage. After starting, avoid the use of carburetor heat unless icing conditions prevail.

After the completion of normal engine starting procedures, it is a good practice to verify that the engine starter has disengaged. If the starter contactor were to stick closed, causing the starter to remain engaged, an excessively high charge indication (full scale at 1000 RPM) would be evident on the ammeter. In this event, immediately shut down the engine and take corrective action prior to flight.

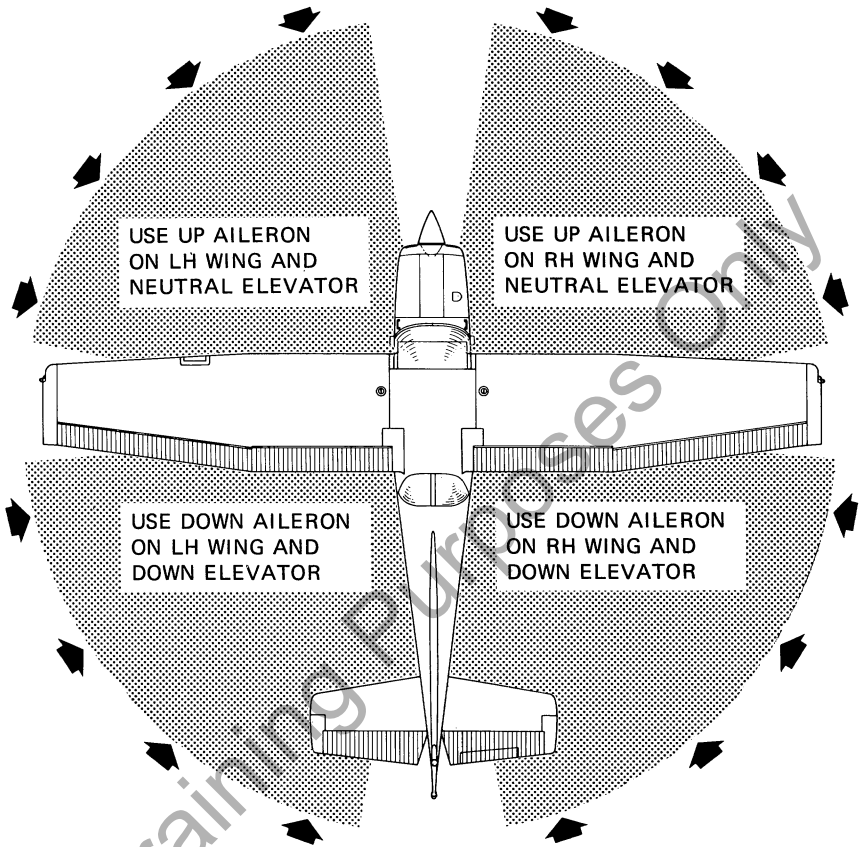

Figure 4-2. Taxiing Diagram

## TAXIING

When taxiing, it is important that speed and use of brakes be held to a minimum and that all controls be utilized (see Taxiing Diagram, figure 4-2) to maintain directional control and balance.

The carburetor heat control knob should be pushed full in during all ground operations unless heat is absolutely necessary for smooth engine operation. When the knob is pulled out to the heat position, air entering the engine is not filtered.

Taxiing over loose gravel or cinders should be done at low engine speed to avoid abrasion and stone damage to the propeller tips.

## BEFORE TAKEOFF

### WARM-UP

Since the engine is closely cowled for efficient in-flight cooling, precautions should be taken to avoid overheating on the ground. Full power checks on the ground are not recommended unless the pilot has good reason to suspect that the engine is not turning up properly.

### MAGNETO CHECK

The magneto check should be made at 1800 RPM as follows. Move ignition switch first to R position and note RPM. Next move switch back to BOTH to clear the other set of plugs. Then move switch to the L position, note RPM and return the switch to the BOTH position. RPM drop should not exceed 150 RPM on either magneto or show greater than 50 RPM differential between magnetos. If RPM drop is excessive, lean to smooth operation and recheck. Return mixture control to FULL RICH position before takeoff from field elevations of less than 3000 feet. If there is a doubt concerning operation of the ignition system, RPM checks at higher engine speeds will usually confirm whether a deficiency exists.

An absence of RPM drop may be an indication of faulty grounding of one side of the ignition system or should be cause for suspicion that the magneto timing is set in advance of the setting specified.

### ALTERNATOR CHECK

Prior to flights where verification of proper alternator and alternator control unit operation is essential (such as night or instrument flights), a positive verification can be made by loading the electrical system momentarily (3 to 5 seconds) with the landing lights during the engine runup (1800 RPM). The ammeter will remain within a needle width of the

initial reading if the alternator and alternator control unit are operating properly.

## **TAKEOFF**

### **POWER CHECK**

It is important to check takeoff power early in the takeoff roll. Any sign of rough engine operation or sluggish engine acceleration is good cause for discontinuing the takeoff.

Full power runups over loose gravel are especially harmful to propeller tips. When takeoffs must be made over a gravel surface, it is very important that the throttle be advanced slowly. This allows the airplane to start rolling before high RPM is developed, and the gravel will be blown back of the propeller rather than pulled into it. When unavoidable small dents appear in the propeller blades they should be corrected immediately as described in Section 8 under Propeller Care.

After full power is applied, adjust the throttle friction lock clockwise to prevent the throttle from creeping from a maximum power position. Similar friction lock adjustment should be made as required in other flight conditions to maintain a fixed throttle setting.

The mixture may be leaned at altitudes above 3000 feet to obtain maximum power. Maximum power may be approximated during a full throttle static runup by leaning to obtain maximum RPM.

### **WING FLAP SETTINGS**

Normal and short field takeoffs are accomplished with wing flaps 0°. To clear an obstacle, an obstacle clearance speed of 63 KIAS should be used.

Soft field takeoffs are performed by lifting the airplane off the ground as soon as practical in a slightly tail-low attitude. If no obstacles are ahead, the airplane should be leveled off immediately to accelerate to a safer climb speed.

At takeoff weights of 2550 pounds or less, 10° flaps may be used if desired for minimum ground roll or takeoffs from soft or rough fields.

### **CROSSWIND TAKEOFF**

Takeoffs into strong crosswinds normally are performed with the minimum flap setting necessary for the field length, to minimize the drift angle immediately after takeoff. With the ailerons partially deflected into

the wind, the airplane is accelerated to a speed slightly higher than normal, and then pulled off abruptly to prevent possible settling back to the runway while drifting. When clear of the ground, make a coordinated turn into the wind to correct for drift.

## LANDING GEAR RETRACTION

Landing gear retraction normally is started after reaching the point over the runway where a wheels-down, forced landing on that runway would become impractical. Since the landing gear swings downward approximately two feet as it starts the retraction cycle, damage can result by retracting it before obtaining at least that much ground clearance.

Before retracting the landing gear, the brakes should be applied momentarily to stop wheel rotation. Centrifugal force caused by the rapidly-spinning wheel expands the diameter of the tire. If there is an accumulation of mud or ice in the wheel wells, the rotating wheel may rub as it is retracted into the wheel well.

## ENROUTE CLIMB

Normal climbs are performed at 85-95 KIAS with flaps up, 25 In. Hg. or full throttle (whichever is less) and 2500 RPM for the best combination of engine cooling, rate of climb and forward visibility. If it is necessary to climb rapidly to clear mountains or reach favorable winds at high altitudes, the best rate-of-climb speed should be used with maximum power. This speed is 84 KIAS at sea level, decreasing to 77 KIAS at 10,000 feet.

If an obstruction ahead requires a steep climb angle, a best angle-of-climb speed should be used with landing gear and flaps up and maximum power. This speed is 67 KIAS at sea level, increasing to 68 KIAS at 10,000 feet.

The mixture should be full rich during climb at altitudes up to 3000 feet. Above 3000 feet, the mixture may be leaned for increased power and smooth engine operation. With the optional Cessna Economy Mixture Indicator, the mixture may be leaned to maintain the EGT indication corresponding to full rich at 3000 feet. Without an EGT indicator, the mixture may be leaned to momentary engine roughness and then enriched two full turns at the mixture control knob. Each of these procedures result in approximately the same mixture and will significantly improve high altitude climb performance.

## CRUISE

Normal cruising is performed between 55% and 75% power. The

corresponding power settings and fuel consumption for various altitudes can be determined by using your Cessna Power Computer or the data in Section 5.

**NOTE**

**Cruising should be done at 75% power as much as practicable until a total of 50 hours has accumulated or oil consumption has stabilized. Operation at this higher power will ensure proper seating of the rings and is applicable to new engines, and engines in service following cylinder replacement or top overhaul of one or more cylinders.**

The Cruise Performance Table, figure 4-3, illustrates the true airspeed and nautical miles per gallon during cruise for various altitudes and percent powers. This table should be used as a guide, along with the available winds aloft information, to determine the most favorable altitudes and power setting for a given trip. The selection of cruise altitude on the basis of the most favorable wind conditions and the use of low power settings are significant factors that should be considered on every trip to reduce fuel consumption.

The tachometer is marked with a green arc from 2100 to 2700 RPM with a step at 2500 RPM. The use of 2500 RPM will allow 75% power at altitudes up to 7500 feet on a standard day. For hot day or high altitude conditions, the cruise RPM may be increased to 2700 RPM. Cruise at 2700 RPM permits the use of 75% power at altitudes up to 9000 feet on a standard day. However, for reduced noise levels it is desirable to select the lowest RPM in the green arc range for a given percent power that will provide smooth engine operation.

The cowl flaps should be opened, if necessary, to maintain the cylinder head temperature at approximately two-thirds of the normal operating range (green arc).

ALTITUDE	75% POWER		65% POWER		55% POWER	
	KTAS	NMPG	KTAS	NMPG	KTAS	NMPG
3000	132	13.2	124	14.2	114	15.0
6000	136	13.6	127	14.6	116	15.3
9000	140	14.0	130	14.9	118	15.6
Standard Conditions					Zero Wind	

Figure 4-3. Cruise Performance Table

Cruise performance data in this handbook and on the power computer is based on a recommended lean mixture setting which may be established as follows:

1. Lean the mixture until the engine becomes rough.
2. Enrichen the mixture to obtain smooth engine operation; then further enrichen an equal amount.

For best fuel economy at 75% power or less, the engine may be operated at the leanest mixture that results in smooth engine operation. This will result in approximately 8% greater range than shown in this handbook accompanied by approximately 3 knots decrease in speed.

Any change in altitude, power or carburetor heat will require a change in the recommended lean mixture setting and a recheck of the EGT setting (if installed).

Carburetor ice, as evidenced by an unexplained drop in manifold pressure, can be removed by application of full carburetor heat. Upon regaining the original manifold pressure indication (with heat off), use the minimum amount of heat (by trial and error) to prevent ice from forming. Since the heated air causes a richer mixture, readjust the mixture setting when carburetor heat is to be used continuously in cruise flight.

### LEANING WITH A CESSNA ECONOMY MIXTURE INDICATOR (EGT)

Exhaust gas temperature (EGT) as shown on the optional Cessna Economy Mixture Indicator may be used as an aid for mixture leaning in cruising flight at 75% power or less. To adjust the mixture, using this indicator, lean to establish the peak EGT as a reference point and then enrichen the mixture by a desired increment based on data in figure 4-4.

MIXTURE DESCRIPTION	EXHAUST GAS TEMPERATURE
RECOMMENDED LEAN (Pilot's Operating Handbook and Power Computer)	50° F Rich of Peak EGT
BEST ECONOMY	Peak EGT

Figure 4-4. EGT Table



As noted in the table, operation at peak EGT provides best fuel economy. This results in approximately 8% greater range than shown in this handbook accompanied by approximately 3 knots decrease in speed.

When leaning the mixture under some conditions, engine roughness may occur before peak EGT is reached. In this case, use the EGT corresponding to the onset of roughness as the reference point instead of peak EGT.

## STALLS

The stall characteristics are conventional and aural warning is provided by a stall warning horn which sounds between 5 and 10 knots above the stall in all configurations.

Power-off stall speeds at maximum weight for both forward and aft C.G. positions are presented in Section 5.

## BEFORE LANDING

In view of the relatively low drag of the extended landing gear and the high allowable gear operating speed (140 KIAS), the landing gear should be extended before entering the traffic pattern. This practice will allow more time to confirm that the landing gear is down and locked. As a further precaution, leave the landing gear extended in go-around procedures or traffic patterns for touch-and-go landings.

Landing gear extension can be detected by illumination of the GEAR LOCKED (green) indicator light, absence of a gear warning horn with the throttle retarded below 12 inches of manifold pressure and/or the wing flaps extended beyond 20°, and visual inspection of the main gear position. Should the gear indicator light fail to illuminate, the light should be checked for a burned-out bulb by pushing to test. A burned-out bulb can be replaced in flight with a post light bulb or the GEAR UNSAFE (red) indicator light.

## LANDING

### NORMAL LANDING

Landings should be made on the main wheels first to reduce the landing speed and the subsequent need for braking in the landing roll. The

nose wheel is lowered gently to the runway after the speed has diminished to avoid unnecessary nose gear load. This procedure is especially important in rough field landings.

## **SHORT FIELD LANDING**

For a short field landing over an obstacle, make a relatively steep, low-power approach at 63 KIAS with 30° flaps. As the obstacle is cleared, reduce power to idle, maintain 63 KIAS and flare to land on the main wheels first. Immediately after touchdown, lower the nose gear to the ground and apply heavy braking as required. For maximum brake effectiveness after all three wheels are on the ground, retract the flaps, hold full nose up elevator and apply maximum possible brake pressure without sliding the tires.

## **CROSSWIND LANDING**

When landing in a strong crosswind, use the minimum flap setting required for the field length. Although the crab or combination method of drift correction may be used, the wing-low method gives the best control. After touchdown, hold a straight course with the steerable nose wheel and occasional braking if necessary.

## **BALKED LANDING**

In a balked landing (go-around) climb, the wing flap setting should be reduced to 20° immediately after full power is applied. After all obstacles are cleared and a safe altitude and airspeed are obtained, the wing flaps should be retracted.

## **COLD WEATHER OPERATION**

Special consideration should be given to the operation of the airplane fuel system during the winter season or prior to any flight in cold temperatures. Proper preflight draining of the fuel system is especially important and will eliminate any free water accumulation. The use of additives such as isopropyl alcohol or ethylene glycol monomethyl ether may also be desirable. Refer to Section 8 for information on the proper use of additives.

Cold weather often causes conditions which require special care during airplane operations. Even small accumulations of frost, ice, or snow should be removed, particularly from wing, tail and all control surfaces to assure satisfactory flight performance and handling. Also, control surfaces must be free of any internal accumulations of ice or snow.

If snow or slush covers the takeoff surface, allowance must be made for takeoff distances which will be increasingly extended as the snow or

slush depth increases. The depth and consistency of this cover can, in fact, prevent takeoff in many instances.

## STARTING

Prior to starting on cold mornings, it is advisable to pull the propeller through several times by hand to "break loose" or "limber" the oil, thus conserving battery energy.

### NOTE

When pulling the propeller through by hand, treat it as if the ignition switch is turned on. A loose or broken ground wire on either magneto could cause the engine to fire.

In extremely cold (-18°C and lower) weather, the use of an external pre-heater and an external power source are recommended whenever possible to obtain positive starting and to reduce wear and abuse to the engine and the electrical system. Pre-heat will thaw the oil trapped in the oil cooler, which probably will be congealed prior to starting in extremely cold temperatures. When using an external power source, the position of the master switch is important. Refer to Section 9, Supplements, for Ground Service Plug Receptacle operating details.

Cold weather starting procedures are as follows:

#### With Preheat:

1. Parking Brake -- SET.
2. Ignition Switch -- OFF.
3. Throttle -- CLOSED.
4. Mixture -- IDLE CUT-OFF.
5. Prime -- 2 to 4 STROKES as the propeller is being turned over by hand. (Use heavy strokes of primer for best atomization of fuel.)

### NOTE

Caution should be used to ensure the brakes are set or a qualified person is at the controls.

6. Primer -- LOCK.
7. Throttle -- OPEN 1/4 INCH.
8. Propeller -- HIGH RPM.
9. Mixture -- FULL RICH.
10. Propeller Area -- CLEAR.
11. Master Switch -- ON.
12. Ignition Switch -- START. (Release ignition switch to BOTH when

engine starts.)

13. Oil Pressure -- CHECK.

**Without Preheat:**

1. Parking Brake -- SET.
2. Ignition Switch -- OFF.
3. Throttle -- CLOSED.
4. Mixture -- IDLE CUT-OFF.
5. Prime -- 4 TO 8 STROKES as the propeller is being turned over by hand. Leave the primer charged and ready for a stroke.

**NOTE**

Caution should be used to ensure the brakes are set or a qualified person is at the controls.

6. Propeller -- HIGH RPM.
7. Mixture -- FULL RICH.
8. Propeller Area -- CLEAR.
9. Master Switch -- ON.
10. Pump throttle rapidly to full open twice. Return to 1/4 inch open position.
11. Ignition Switch -- START.
12. Release ignition switch to BOTH when engine starts.
13. Continue to prime engine until it is running smoothly, or alternately, pump throttle rapidly over first 1/4 of total travel.
14. Oil Pressure -- CHECK.
15. Pull carburetor heat knob full on after engine has started. Leave on until engine is running smoothly.
16. Primer -- LOCK.

**NOTE**

If the engine does not start during the first few attempts, or if engine firing diminishes in strength, it is probable that the spark plugs have been frosted over. Preheat must be used before another start is attempted.

**CAUTION**

Excessive pumping of the throttle may cause raw fuel to accumulate in the intake manifold, creating a fire hazard in the event of a backfire. If this occurs, maintain a cranking action to suck flames into the engine. An outside attendant with a fire extinguisher is advised for cold starts without preheat.

## OPERATION

During cold weather operations, no indication will be apparent on the oil temperature gage prior to takeoff if outside air temperatures are very cold. After a suitable warm-up period (2 to 5 minutes at 1000 RPM), accelerate the engine several times to higher engine RPM. If the engine accelerates smoothly and the oil pressure remains normal and steady, the airplane is ready for takeoff.

Rough engine operation in cold weather can be caused by a combination of an inherently leaner mixture due to the dense air and poor vaporization and distribution of the fuel-air mixture to the cylinders. The effects of these conditions are especially noticeable during operation on one magneto in ground checks where only one spark plug fires in each cylinder.

For optimum operation of the engine in cold weather, the appropriate use of carburetor heat may be necessary. The following procedures are indicated as a guideline:

1. Use the minimum carburetor heat required for smooth operation in takeoff, climb, and cruise.

### NOTE

Care should be exercised when using partial carburetor heat to avoid icing. Partial heat may raise the carburetor air temperature to 0° to 21°C range where icing is critical under certain atmospheric conditions.

2. If the airplane is equipped with a carburetor air temperature gage, it can be used as a reference in maintaining carburetor air temperature at or slightly above the top of the yellow arc by application of carburetor heat.

## HOT WEATHER OPERATION

The general warm temperature starting information in this section is appropriate. Avoid prolonged engine operation on the ground.

## NOISE CHARACTERISTICS

Increased emphasis on improving the quality of our environment requires renewed effort on the part of all pilots to minimize the effect of airplane noise on the public.

We, as pilots, can demonstrate our concern for environmental improvement, by application of the following suggested procedures, and thereby tend to build public support for aviation:

1. Pilots operating aircraft under VFR over outdoor assemblies of persons, recreational and park areas, and other noise-sensitive areas should make every effort to fly not less than 2000 feet above the surface, weather permitting, even though flight at a lower level may be consistent with the provisions of government regulations.
2. During departure from or approach to an airport, climb after takeoff and descent for landing should be made so as to avoid prolonged flight at low altitude near noise-sensitive areas.

#### NOTE

The above recommended procedures do not apply where they would conflict with Air Traffic Control clearances or instructions, or where, in the pilot's judgment, an altitude of less than 2000 feet is necessary for him to adequately exercise his duty to see and avoid other aircraft.

The certificated noise level for the Model 172RG at 2650 pounds maximum weight is 73.9 dB(A). No determination has been made by the Federal Aviation Administration that the noise levels of this airplane are or should be acceptable or unacceptable for operation at, into, or out of, any airport.

# SECTION 5 PERFORMANCE

## TABLE OF CONTENTS

	Page
Introduction . . . . .	5-3
Use of Performance Charts . . . . .	5-3
Sample Problem . . . . .	5-3
Takeoff . . . . .	5-4
Cruise . . . . .	5-5
Fuel Required . . . . .	5-5
Landing . . . . .	5-7
Demonstrated Operating Temperature . . . . .	5-7
Figure 5-1, Airspeed Calibration - Normal Static Source . . . . .	5-9
Airspeed Calibration - Alternate Static Source . . . . .	5-10
Figure 5-2, Temperature Conversion Chart . . . . .	5-11
Figure 5-3, Stall Speeds . . . . .	5-12
Figure 5-4, Wind Components . . . . .	5-13
Figure 5-5, Takeoff Distance - 2650 Lbs . . . . .	5-14
Takeoff Distance - 2500 Lbs And 2300 Lbs . . . . .	5-15
Figure 5-6, Maximum Rate Of Climb . . . . .	5-16
Figure 5-7, Time, Fuel, And Distance To Climb - Maximum Rate Of Climb . . . . .	5-17
Time, Fuel, And Distance To Climb - Normal Climb . . . . .	5-18
Figure 5-8, Cruise Performance - 2000 Feet . . . . .	5-19
Cruise Performance - 4000 Feet . . . . .	5-20
Cruise Performance - 6000 Feet . . . . .	5-21
Cruise Performance - 8000 Feet . . . . .	5-22
Cruise Performance - 10,000 Feet . . . . .	5-23
Cruise Performance - 12,000 Feet . . . . .	5-24
Figure 5-9, Range Profile - 44 Gallons Fuel . . . . .	5-25
Range Profile - 62 Gallons Fuel . . . . .	5-26
Figure 5-10, Endurance Profile - 44 Gallons Fuel . . . . .	5-27
Endurance Profile - 62 Gallons Fuel . . . . .	5-28
Figure 5-11, Landing Distance . . . . .	5-29

For Training Purposes Only



## INTRODUCTION

Performance data charts on the following pages are presented so that you may know what to expect from the airplane under various conditions, and also, to facilitate the planning of flights in detail and with reasonable accuracy. The data in the charts has been computed from actual flight tests with the airplane and engine in good condition and using average piloting techniques.

It should be noted that the performance information presented in the range and endurance profile charts allows for 45 minutes reserve fuel at the specified cruise power. Fuel flow data for cruise is based on the recommended lean mixture setting. Some indeterminate variables such as mixture leaning technique, fuel metering characteristics, engine and propeller condition, and air turbulence may account for variations of 10% or more in range and endurance. Therefore, it is important to utilize all available information to estimate the fuel required for the particular flight.

## USE OF PERFORMANCE CHARTS

Performance data is presented in tabular or graphical form to illustrate the effect of different variables. Sufficiently detailed information is provided in the tables so that conservative values can be selected and used to determine the particular performance figure with reasonable accuracy.

## SAMPLE PROBLEM

The following sample flight problem utilizes information from the various charts to determine the predicted performance data for a typical flight. The following information is known:

### AIRPLANE CONFIGURATION

Takeoff weight	2600 Pounds
Usable fuel	44 Gallons

### TAKEOFF CONDITIONS

Field pressure altitude	1500 Feet
Temperature	28°C (16°C above standard)
Wind component along runway	12 Knot Headwind
Field length	3500 Feet

**CRUISE CONDITIONS**

Total distance	425 Nautical Miles
Pressure altitude	7500 Feet
Temperature	16°C (16°C above standard)
Expected wind enroute	10 Knot Headwind

**LANDING CONDITIONS**

Field pressure altitude	2000 Feet
Temperature	25°C
Field length	3000 Feet

**TAKEOFF**

The takeoff distance chart, figure 5-5, should be consulted, keeping in mind that the distances shown are based on the short field technique. Conservative distances can be established by reading the chart at the next higher value of weight, altitude and temperature. For example, in this particular sample problem, the takeoff distance information presented for a weight of 2650 pounds, pressure altitude of 2000 feet and a temperature of 30°C should be used and results in the following:

Ground roll	1410 Feet
Total distance to clear a 50-foot obstacle	2380 Feet

These distances are well within the available takeoff field length. However, a correction for the effect of wind may be made based on Note 3 of the takeoff chart. The correction for a 12 knot headwind is:

$$\frac{12 \text{ Knots}}{9 \text{ Knots}} \times 10\% = 13\% \text{ Decrease}$$

This results in the following distances, corrected for wind:

Ground roll, zero wind	1410
Decrease in ground roll (1410 feet × 13%)	<u>183</u>
Corrected ground roll	1227 Feet
Total distance to clear a 50-foot obstacle, zero wind	2380
Decrease in total distance (2380 feet × 13%)	<u>309</u>
Corrected total distance to clear 50-foot obstacle	2071 Feet

## CRUISE

The cruising altitude should be selected based on a consideration of trip length, winds aloft, and the airplane's performance. A cruising altitude and the expected wind enroute have been given for this sample problem. However, the power setting selection for cruise must be determined based on several considerations. These include the cruise performance characteristics presented in figure 5-8, the range profile charts presented in figure 5-9, and the endurance profile charts presented in figure 5-10.

The relationship between power and range is illustrated by the range profile charts. Considerable fuel savings and longer range result when lower power settings are used. For this sample problem, a cruise power of approximately 65% will be used.

The cruise performance chart for 8000 feet pressure altitude is entered using 20°C above standard temperature. These values most nearly correspond to the planned altitude and expected temperature conditions. The power setting chosen is 2300 RPM and 22 inches of manifold pressure, which results in the following:

Power	65%
True airspeed	132 Knots
Cruise fuel flow	8.8 GPH

The power computer may be used to determine power and fuel consumption more accurately during the flight.

## FUEL REQUIRED

The total fuel requirement for the flight may be estimated using the performance information in figures 5-7 and 5-8. For this sample problem, figure 5-7 shows that a normal climb from 2000 feet to 8000 feet requires 2.4 gallons of fuel. The corresponding distance during the climb is 20 nautical miles. These values are for a standard temperature and are sufficiently accurate for most flight planning purposes. However, a further correction for the effect of temperature may be made as noted on the climb chart. The approximate effect of a non-standard temperature is to increase the time, fuel, and distance by 10% for each 10°C above standard temperature, due to the lower rate of climb. In this case, assuming a temperature 16°C above standard, the correction would be:

$$\frac{16^{\circ}\text{C}}{10^{\circ}\text{C}} \times 10\% = 16\% \text{ Increase}$$

SECTION 5  
PERFORMANCE

CESSNA  
MODEL 172RG

With this factor included, the fuel estimate would be calculated as follows:

Fuel to climb, standard temperature	2.4
Increase due to non-standard temperature (2.4 × 16%)	<u>0.4</u>
Corrected fuel to climb	2.8 Gallons

Using a similar procedure for the distance during climb results in 23 nautical miles.

The resultant cruise distance is:

Total distance	425
Climb distance	<u>-23</u>
Cruise distance	402 Nautical Miles

With an expected 10 knot headwind, the ground speed for cruise is predicted to be:

132
<u>-10</u>
122 Knots

Therefore, the time required for the cruise portion of the trip is:

$$\frac{402 \text{ Nautical Miles}}{122 \text{ Knots}} = 3.3 \text{ Hours}$$

The fuel required for cruise is:

$$3.3 \text{ hours} \times 8.8 \text{ gallons/hour} = 29.0 \text{ Gallons}$$

A 45-minute reserve requires:

$$\frac{45}{60} \times 8.8 \text{ gallons/hour} = 6.6 \text{ Gallons}$$

The total estimated fuel required is as follows:

Engine start, taxi, and takeoff	1.4
Climb	2.8
Cruise	29.0
Reserve	<u>6.6</u>
Total fuel required	39.8 Gallons

Once the flight is underway, ground speed checks will provide a more accurate basis for estimating the time enroute and the corresponding fuel required to complete the trip with ample reserve.

## LANDING

A procedure similar to takeoff should be used for estimating the landing distance at the destination airport. Figure 5-11 presents landing distance information for the short field technique. The distances corresponding to 2000 feet pressure altitude and a temperature of 30°C are as follows:

Ground roll	705 Feet
Total distance to clear a 50-foot obstacle	1465 Feet

A correction for the effect of wind may be made based on Note 2 of the landing chart using the same procedure as outlined for takeoff.

## DEMONSTRATED OPERATING TEMPERATURE

Satisfactory engine cooling has been demonstrated for this airplane with an outside air temperature 23°C above standard. This is not to be considered as an operating limitation. Reference should be made to Section 2 for engine operating limitations.

For Training Purposes Only

## AIRSPEED CALIBRATION

### NORMAL STATIC SOURCE

CONDITIONS:  
Power required for level flight or maximum power during descent.

FLAPS UP												
KIAS	50	60	70	80	90	100	110	120	130	140	150	160
KCAS	55	63	71	80	89	99	108	118	128	138	147	157
FLAPS 10°												
KIAS	40	50	60	70	80	90	100	110	120	130	---	---
KCAS	50	54	62	71	81	91	100	110	120	130	---	---
FLAPS 30°												
KIAS	40	50	60	70	80	90	100	---	---	---	---	---
KCAS	47	54	62	71	81	90	101	---	---	---	---	---

Figure 5-1. Airspeed Calibration (Sheet 1 of 2)

## AIRSPEED CALIBRATION

### ALTERNATE STATIC SOURCE

#### HEATER AND DEFROSTER FULL ON AND WINDOWS CLOSED

FLAPS UP										
NORMAL KIAS	50	60	70	80	90	100	110	120	140	160
ALTERNATE KIAS	46	58	69	79	88	98	108	117	136	155
FLAPS 10°										
NORMAL KIAS	50	60	70	80	90	100	110	120	130	---
ALTERNATE KIAS	45	58	69	80	90	100	109	119	128	---
FLAPS 30°										
NORMAL KIAS	50	60	70	80	90	100	---	---	---	---
ALTERNATE KIAS	46	58	68	78	87	96	---	---	---	---

Figure 5-1. Airspeed Calibration (Sheet 2 of 2)



# TEMPERATURE CONVERSION CHART

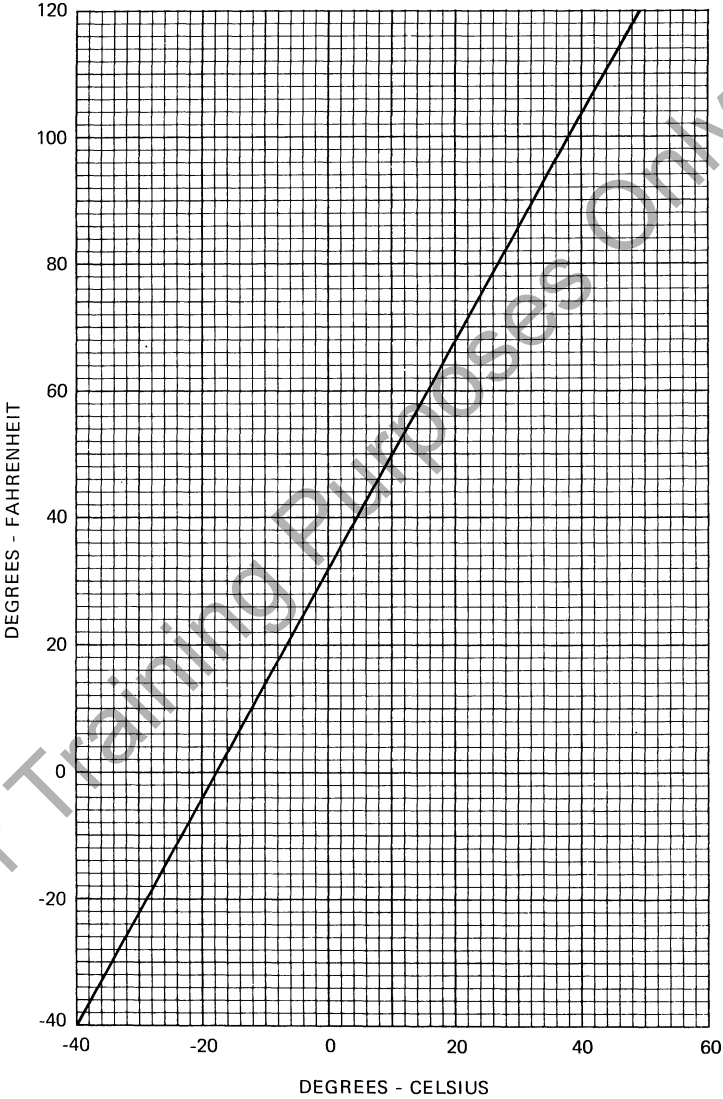

Figure 5-2. Temperature Conversion Chart

## STALL SPEEDS

**CONDITIONS:**

Power Off  
Gear Up or Down

**NOTES:**

- Altitude loss during a stall recovery may be as much as 230 feet.
- KIAS values are approximate.

### MOST REARWARD CENTER OF GRAVITY

WEIGHT LBS	FLAP DEFLECTION	ANGLE OF BANK							
		0°		30°		45°		60°	
		KIAS	KCAS	KIAS	KCAS	KIAS	KCAS	KIAS	KCAS
2650	UP	46	54	49	58	55	64	65	76
	10°	42	52	45	56	50	62	59	74
	30°	39	50	42	54	47	59	56	71

### MOST FORWARD CENTER OF GRAVITY

WEIGHT LBS	FLAP DEFLECTION	ANGLE OF BANK							
		0°		30°		45°		60°	
		KIAS	KCAS	KIAS	KCAS	KIAS	KCAS	KIAS	KCAS
2650	UP	50	57	54	61	59	68	71	81
	10°	46	54	49	58	55	64	65	76
	30°	42	51	45	55	50	61	59	72

Figure 5-3. Stall Speeds

## WIND COMPONENTS

NOTE:

Maximum demonstrated crosswind velocity is 15 knots (not a limitation).

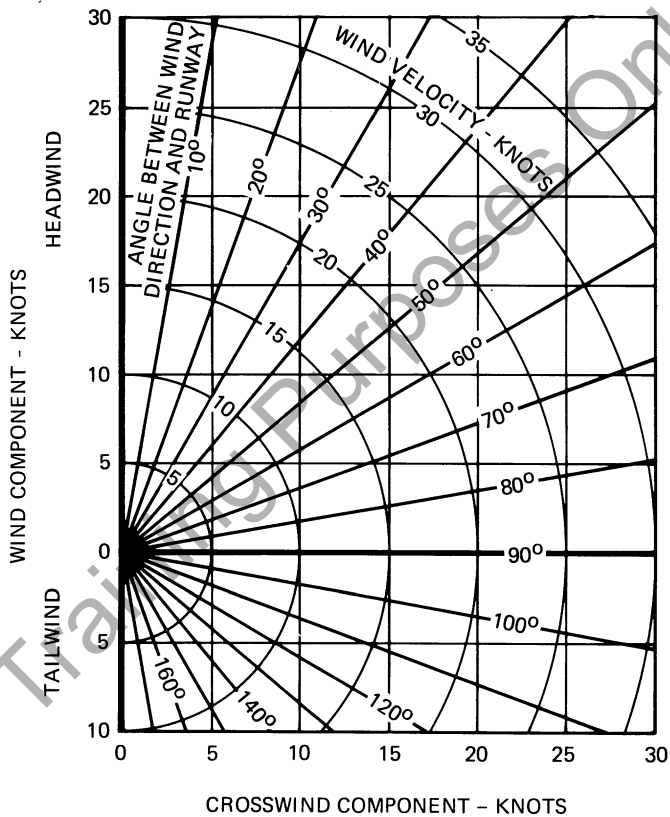

Figure 5-4. Wind Components

# TAKEOFF DISTANCE

## MAXIMUM WEIGHT 2650 LBS

### SHORT FIELD

**CONDITIONS:**

- Flaps Up
- 2700 RPM and Full Throttle Prior to Brake Release
- Cowl Flaps Open
- Paved, Level Dry Runway
- Zero Wind

**NOTES:**

1. Short field technique as specified in Section 4.
2. Prior to takeoff from fields above 3000 feet elevation, the mixture should be leaned to give maximum power in a full throttle, static runup.
3. Decrease distances 10% for each 9 knots headwind. For operation with tailwinds up to 10 knots, increase distances by 10% for each 2 knots.
4. For operation on a dry, grass runway, increase distances by 15% of the "ground roll" figure.

WEIGHT LBS	TAKEOFF SPEED KIAS		PRESS ALT FT	0°C		10°C		20°C		30°C		40°C	
				TOTAL FT TO CLEAR 50 FT OBS		TOTAL FT TO CLEAR 50 FT OBS		TOTAL FT TO CLEAR 50 FT OBS		TOTAL FT TO CLEAR 50 FT OBS		TOTAL FT TO CLEAR 50 FT OBS	
	GRND ROLL FT	GRND ROLL FT		GRND ROLL FT	GRND ROLL FT	GRND ROLL FT	GRND ROLL FT	GRND ROLL FT	GRND ROLL FT	GRND ROLL FT	GRND ROLL FT	GRND ROLL FT	GRND ROLL FT
2650	58	63	S.L.	955	1605	1025	1715	1100	1835	1175	1965	1260	2100
			1000	1040	1755	1120	1880	1200	2015	1285	2155	1375	2310
			2000	1140	1925	1225	2065	1315	2215	1410	2380	1510	2550
			3000	1250	2120	1340	2280	1440	2450	1545	2630	1655	2830
			4000	1370	2345	1475	2525	1585	2715	1700	2930	1820	3160
			5000	1505	2600	1620	2805	1740	3030	1870	3280	2005	3550
			6000	1660	2905	1785	3145	1920	3405	2065	3700	2215	4025
			7000	1830	3265	1970	3545	2120	3865	2280	4220	2450	4630
		8000	2025	3700	2180	4045	2350	4440	2530	4895	2720	5430	

Figure 5-5. Takeoff Distance (Sheet 1 of 2)

**TAKEOFF DISTANCE**  
**2500 LBS AND 2300 LBS**

**SHORT FIELD**

REFER TO SHEET 1 FOR APPROPRIATE CONDITIONS AND NOTES.

WEIGHT LBS	TAKEOFF SPEED KIAS		PRESS ALT FT	0°C			10°C			20°C			30°C			40°C		
	LIFT OFF	AT 50 FT		GRND ROLL FT	TOTAL FT TO CLEAR 50 FT OBS	GRND ROLL FT	TOTAL FT TO CLEAR 50 FT OBS	GRND ROLL FT	TOTAL FT TO CLEAR 50 FT OBS	GRND ROLL FT	TOTAL FT TO CLEAR 50 FT OBS	GRND ROLL FT	TOTAL FT TO CLEAR 50 FT OBS	GRND ROLL FT	TOTAL FT TO CLEAR 50 FT OBS	GRND ROLL FT	TOTAL FT TO CLEAR 50 FT OBS	
2500	56	61	S.L.	835	1400	895	1495	960	1595	1025	1705	1100	1820	1200	1865	1200	1995	
			2000	910	1525	975	1635	1045	1745	1120	1865	1200	1995					
	3000	3000	3000	1090	1835	1070	1790	1145	1915	1225	2050	1315	2195	1315	2050	1315	2195	
			4000	1195	2015	1170	1965	1255	2105	1345	2260	1440	2420	1440	2260	1440	2420	
	2300	54	59	5000	1310	2230	1280	2165	1375	2325	1475	2500	1580	2685	1580	2500	1580	2685
				6000	1440	2470	1410	2400	1515	2580	1625	2780	1740	2990	1740	2780	1740	2990
		8000	8000	7000	1585	2760	1550	2665	1665	2875	1790	3105	1920	3355	1920	3105	1920	3355
				8000	1755	3095	1890	3360	2035	3655	2185	3980	2350	4350	2350	3980	2350	4350
2300	54	59	S.L.	690	1160	740	1240	790	1320	845	1405	905	1500	845	1405	905	1500	
			2000	750	1265	805	1350	860	1440	920	1535	985	1635	985	1635	985	1635	
	3000	3000	3000	820	1380	880	1475	940	1575	1010	1680	1080	1795	1080	1680	1080	1795	
			4000	895	1505	960	1610	1030	1725	1105	1845	1180	1970	1180	1845	1180	1970	
	2300	54	59	5000	980	1650	1050	1770	1130	1895	1210	2025	1295	2170	1295	2025	1295	2170
				6000	1075	1815	1155	1950	1240	2090	1325	2240	1420	2400	1420	2240	1420	2400
		8000	8000	7000	1180	2005	1265	2150	1360	2310	1460	2485	1565	2670	1565	2485	1565	2670
				8000	1295	2220	1395	2385	1500	2570	1610	2765	1725	2980	1725	2765	1725	2980

Figure 5-5. Takeoff Distance (Sheet 2 of 2)

## MAXIMUM RATE OF CLIMB

**CONDITIONS:**

Flaps Up  
Gear Up  
2700 RPM  
Full Throttle  
Mixture Leaned above 3000 Feet  
Cowl Flaps Open

WEIGHT LBS	PRESS ALT FT	CLIMB SPEED KIAS	RATE OF CLIMB - FPM			
			-20°C	0°C	20°C	40°C
2650	S.L.	84	925	855	780	710
	2000	83	825	755	685	620
	4000	81	720	655	590	525
	6000	80	620	560	495	435
	8000	78	525	465	405	340
	10,000	77	430	370	310	---
	12,000	75	330	275	220	---

Figure 5-6. Maximum Rate of Climb

## TIME, FUEL, AND DISTANCE TO CLIMB

### MAXIMUM RATE OF CLIMB

**CONDITIONS:**

Flaps Up  
Gear Up  
2700 RPM  
Full Throttle  
Mixture Leaned above 3000 Feet  
Cowl Flaps Open  
Standard Temperature

**NOTES:**

1. Add 1.4 gallons of fuel for engine start, taxi, and takeoff allowance.
2. Increase time, fuel and distance by 10% for each 10°C above standard temperature.
3. Distances shown are based on zero wind.

WEIGHT LBS	PRESSURE ALTITUDE FT	TEMP °C	CLIMB SPEED KIAS	RATE OF CLIMB FPM	FROM SEA LEVEL		
					TIME MIN	FUEL USED GALLONS	DISTANCE NM
2650	S.L.	15	84	800	0	0.0	0
	1000	13	83	760	1	0.4	2
	2000	11	83	715	3	0.8	4
	3000	9	82	675	4	1.1	6
	4000	7	81	635	6	1.6	8
	5000	5	81	590	7	2.0	10
	6000	3	80	550	9	2.4	13
	7000	1	79	510	11	2.9	16
	8000	-1	78	465	13	3.3	19
	9000	-3	78	425	15	3.8	22
	10,000	-5	77	385	18	4.3	26
	11,000	-7	76	340	21	4.9	30
12,000	-9	75	300	24	5.5	35	

Figure 5-7. Time, Fuel, and Distance to Climb (Sheet 1 of 2)

## TIME, FUEL, AND DISTANCE TO CLIMB

### NORMAL CLIMB - 90 KIAS

**CONDITIONS:**

Flaps Up  
Gear Up  
2500 RPM  
25 Inches Hg or Full Throttle  
Mixture Leaned above 3000 Feet  
Cowl Flaps Open  
Standard Temperature

**NOTES:**

1. Add 1.4 gallons of fuel for engine start, taxi, and takeoff allowance.
2. Increase time, fuel and distance by 10% for each 10°C above standard temperature.
3. Distances shown are based on zero wind.

WEIGHT LBS	PRESSURE ALTITUDE FT	TEMP °C	RATE OF CLIMB FPM	FROM SEA LEVEL		
				TIME MIN	FUEL USED GALLONS	DISTANCE NM
2650	S.L.	15	530	0	0.0	0
	1000	13	530	2	0.4	3
	2000	11	530	4	0.7	6
	3000	9	530	6	1.1	9
	4000	7	530	8	1.4	12
	5000	5	520	9	1.8	15
	6000	3	475	11	2.2	18
	7000	1	430	14	2.6	22
	8000	-1	385	16	3.1	26

Figure 5-7. Time, Fuel, and Distance to Climb (Sheet 2 of 2)



## CRUISE PERFORMANCE

### PRESSURE ALTITUDE 2000 FEET

CONDITIONS:  
2650 Pounds  
Recommended Lean Mixture  
Cowl Flaps Closed

**NOTE**

For best fuel economy, operate at the leanest mixture that results in smooth engine operation or at peak EGT if an EGT indicator is installed.

		20°C BELOW STANDARD TEMP -9°C			STANDARD TEMPERATURE 11°C			20°C ABOVE STANDARD TEMP 31°C		
RPM	MP	% BHP	KTAS	GPH	% BHP	KTAS	GPH	% BHP	KTAS	GPH
2500	24	77	130	10.3	74	131	9.9	72	132	9.6
	23	72	127	9.7	70	128	9.4	68	128	9.1
	22	68	123	9.1	66	124	8.8	63	124	8.6
	21	63	120	8.6	61	120	8.3	59	120	8.1
2400	25	---	---	---	76	132	10.1	73	133	9.8
	24	74	128	9.9	72	129	9.6	69	130	9.3
	23	70	125	9.3	67	126	9.0	65	126	8.8
	22	65	121	8.8	63	122	8.5	61	122	8.3
2300	25	76	129	10.1	73	130	9.7	71	131	9.4
	24	71	126	9.5	69	127	9.2	67	127	8.9
	23	67	123	9.0	65	123	8.7	63	123	8.5
	22	63	119	8.5	61	119	8.2	59	119	8.0
2200	24	69	124	9.2	66	124	8.9	64	125	8.6
	23	64	121	8.7	62	121	8.4	60	120	8.2
	22	60	117	8.2	58	116	7.9	56	116	7.7
	21	56	112	7.7	54	112	7.5	52	111	7.3
2100	23	62	118	8.3	59	118	8.1	57	118	7.9
	22	57	114	7.9	55	114	7.6	54	113	7.4
	21	53	109	7.4	52	109	7.2	50	108	7.0
	20	49	105	6.9	48	103	6.7	46	101	6.6

Figure 5-8. Cruise Performance (Sheet 1 of 6)

## CRUISE PERFORMANCE

### PRESSURE ALTITUDE 4000 FEET

CONDITIONS:  
2650 Pounds  
Recommended Lean Mixture  
Cowl Flaps Closed

**NOTE**  
For best fuel economy, operate at the leanest mixture that results in smooth engine operation or at peak EGT if an EGT indicator is installed.

		20°C BELOW STANDARD TEMP -13°C			STANDARD TEMPERATURE 7°C			20°C ABOVE STANDARD TEMP 27°C		
RPM	MP	% BHP	KTAS	GPH	% BHP	KTAS	GPH	% BHP	KTAS	GPH
2500	24	---	---	---	77	135	10.2	74	136	9.9
	23	75	131	10.0	72	132	9.7	70	132	9.4
	22	70	127	9.4	68	128	9.1	66	128	8.8
	21	66	124	8.8	63	124	8.6	61	124	8.3
2400	24	77	132	10.2	74	133	9.9	72	134	9.6
	23	72	129	9.7	70	130	9.3	67	130	9.0
	22	68	126	9.1	65	126	8.8	63	126	8.5
	21	63	122	8.6	61	121	8.3	59	121	8.1
2300	25	---	---	---	76	134	10.1	73	135	9.7
	24	74	130	9.9	71	131	9.5	69	131	9.2
	23	70	127	9.3	67	127	9.0	65	127	8.7
	22	65	123	8.8	63	123	8.5	61	123	8.3
2200	24	71	128	9.5	69	129	9.2	66	129	8.9
	23	67	125	9.0	65	125	8.7	62	125	8.4
	22	63	121	8.5	60	121	8.2	58	120	8.0
	21	58	116	8.0	56	116	7.7	54	115	7.5
2100	23	64	122	8.6	62	122	8.4	60	122	8.1
	22	60	118	8.2	58	118	7.9	56	117	7.7
	21	56	114	7.7	54	113	7.4	52	112	7.2
	20	52	109	7.2	50	108	7.0	48	106	6.8
	19	48	103	6.7	46	101	6.6	44	98	6.4

Figure 5-8. Cruise Performance (Sheet 2 of 6)

## CRUISE PERFORMANCE

### PRESSURE ALTITUDE 6000 FEET

CONDITIONS:  
2650 Pounds  
Recommended Lean Mixture  
Cowl Flaps Closed

**NOTE**  
For best fuel economy, operate at the leanest mixture that results in smooth engine operation or at peak EGT if an EGT indicator is installed.

		20°C BELOW STANDARD TEMP -17°C			STANDARD TEMPERATURE 3°C			20°C ABOVE STANDARD TEMP 23°C		
RPM	MP	% BHP	KTAS	GPH	% BHP	KTAS	GPH	% BHP	KTAS	GPH
2500	23	---	---	---	75	136	10.0	72	136	9.6
	22	73	132	9.7	70	132	9.4	68	132	9.1
	21	68	128	9.1	66	128	8.8	63	128	8.6
	20	63	123	8.6	61	123	8.3	59	123	8.1
2400	24	---	---	---	77	137	10.2	74	138	9.9
	23	75	133	10.0	72	134	9.6	70	134	9.3
	22	70	130	9.4	68	130	9.1	66	130	8.8
	21	66	126	8.8	63	126	8.6	61	125	8.3
2300	24	77	134	10.2	74	135	9.8	71	136	9.5
	23	72	131	9.6	70	132	9.3	67	132	9.0
	22	68	127	9.1	65	128	8.8	63	127	8.5
	21	63	123	8.5	61	123	8.3	59	123	8.0
2200	24	74	132	9.9	71	133	9.5	69	133	9.2
	23	70	129	9.3	67	129	9.0	65	129	8.7
	22	65	125	8.8	63	125	8.5	61	125	8.2
	21	61	121	8.3	59	120	8.0	57	120	7.8
2100	23	67	126	8.9	64	126	8.7	62	126	8.4
	22	62	122	8.5	60	122	8.2	58	122	7.9
	21	58	118	8.0	56	117	7.7	54	117	7.5
	20	54	113	7.5	52	112	7.3	50	110	7.0
	19	50	108	7.0	48	106	6.8	46	103	6.6

Figure 5-8. Cruise Performance (Sheet 3 of 6)

## CRUISE PERFORMANCE

### PRESSURE ALTITUDE 8000 FEET

CONDITIONS:  
2650 Pounds  
Recommended Lean Mixture  
Cowl Flaps Closed

NOTE

For best fuel economy, operate at the leanest mixture that results in smooth engine operation or at peak EGT if an EGT indicator is installed.

		20°C BELOW STANDARD TEMP -21°C			STANDARD TEMPERATURE -1°C			20°C ABOVE STANDARD TEMP 19°C		
RPM	MP	% BHP	KTAS	GPH	% BHP	KTAS	GPH	% BHP	KTAS	GPH
2700	22	---	---	---	77	140	10.3	74	141	9.9
	21	75	135	10.0	72	136	9.6	70	136	9.3
2600	22	---	---	---	75	138	10.0	72	139	9.6
	21	73	134	9.7	70	134	9.4	68	134	9.1
	20	68	129	9.1	65	129	8.8	63	129	8.5
2500	22	75	136	10.0	73	136	9.7	70	137	9.4
	21	71	132	9.4	68	132	9.1	66	132	8.8
	20	66	128	8.8	63	127	8.6	61	127	8.3
	19	61	123	8.3	59	122	8.0	57	121	7.8
2400	22	73	134	9.7	70	134	9.4	68	134	9.1
	21	68	130	9.1	66	130	8.8	63	129	8.6
	20	64	125	8.6	61	125	8.3	59	124	8.1
	19	59	120	8.0	57	120	7.8	55	118	7.6
2300	22	70	132	9.4	68	132	9.1	65	132	8.8
	21	66	128	8.8	63	127	8.5	61	127	8.3
	20	61	123	8.3	59	122	8.0	57	121	7.8
	19	57	118	7.8	55	117	7.5	53	115	7.3
2200	22	68	129	9.1	65	129	8.8	63	129	8.5
	21	63	125	8.5	61	125	8.3	59	124	8.0
	20	59	120	8.0	57	120	7.8	55	118	7.6
	19	54	115	7.5	52	114	7.3	51	112	7.1
2100	22	65	127	8.7	63	127	8.5	60	126	8.2
	21	61	122	8.2	59	122	8.0	57	121	7.7
	20	56	117	7.7	54	116	7.5	53	115	7.3
	19	52	112	7.3	50	110	7.0	49	108	6.8
	18	48	105	6.8	46	102	6.6	45	99	6.4

Figure 5-8. Cruise Performance (Sheet 4 of 6)

## CRUISE PERFORMANCE

### PRESSURE ALTITUDE 10,000 FEET

CONDITIONS:  
2650 Pounds  
Recommended Lean Mixture  
Cowl Flaps Closed

**NOTE**  
For best fuel economy, operate at the leanest mixture that results in smooth engine operation or at peak EGT if an EGT indicator is installed.

		20°C BELOW STANDARD TEMP -25°C			STANDARD TEMPERATURE -5°C			20°C ABOVE STANDARD TEMP 15°C		
RPM	MP	% BHP	KTAS	GPH	% BHP	KTAS	GPH	% BHP	KTAS	GPH
2700	20	72	136	9.7	70	136	9.3	67	136	9.0
	19	67	131	9.0	65	131	8.7	62	130	8.4
2600	20	70	134	9.4	68	134	9.0	65	133	8.8
	19	65	129	8.8	63	128	8.5	61	128	8.2
	18	60	123	8.2	58	123	7.9	56	121	7.7
2500	20	68	132	9.1	66	132	8.8	63	131	8.5
	19	63	127	8.5	61	126	8.3	59	125	8.0
	18	58	121	8.0	56	120	7.7	54	119	7.5
	17	54	115	7.4	52	113	7.2	50	110	7.0
2400	20	66	130	8.9	63	129	8.6	61	129	8.3
	19	61	124	8.3	59	124	8.0	57	123	7.8
	18	56	119	7.7	54	118	7.5	52	115	7.3
	17	52	112	7.2	50	110	7.0	48	107	6.8
2300	20	64	127	8.6	61	127	8.3	59	126	8.0
	19	59	122	8.0	57	121	7.8	55	119	7.5
	18	54	116	7.5	52	114	7.3	51	112	7.1
	17	50	109	7.0	48	106	6.8	46	103	6.6
2200	20	61	125	8.3	59	124	8.0	57	123	7.8
	19	57	119	7.8	55	118	7.5	53	116	7.3
	18	52	113	7.3	50	111	7.0	49	108	6.9
2100	20	59	122	8.0	57	121	7.8	55	119	7.5
	19	55	116	7.5	52	115	7.3	51	112	7.1
	18	50	110	7.0	48	107	6.8	47	104	6.6

Figure 5-8. Cruise Performance (Sheet 5 of 6)

## CRUISE PERFORMANCE

### PRESSURE ALTITUDE 12,000 FEET

CONDITIONS:  
2650 Pounds  
Recommended Lean Mixture  
Cowl Flaps Closed

**NOTE**  
For best fuel economy, operate at the leanest mixture that results in smooth engine operation or at peak EGT if an EGT indicator is installed.

		20°C BELOW STANDARD TEMP -29°C			STANDARD TEMPERATURE -9°C			20°C ABOVE STANDARD TEMP +11°C		
RPM	MP	% BHP	KTAS	GPH	% BHP	KTAS	GPH	% BHP	KTAS	GPH
2700	19	69	135	9.3	67	135	9.0	64	134	8.7
	18	64	130	8.7	62	129	8.4	60	128	8.1
2600	19	67	133	9.0	65	133	8.7	63	132	8.5
	18	62	128	8.4	60	127	8.2	58	125	7.9
	17	57	121	7.8	55	120	7.6	53	117	7.4
2500	19	65	131	8.8	63	131	8.5	61	130	8.3
	18	61	126	8.2	58	125	8.0	56	123	7.7
	17	56	119	7.6	54	117	7.4	52	115	7.2
	16	51	112	7.1	49	108	6.9	47	104	6.7
2400	19	63	129	8.6	61	128	8.3	59	127	8.0
	18	59	123	7.8	56	122	7.7	54	120	7.5
	17	54	117	7.4	52	114	7.2	50	111	7.0
	16	49	108	6.9	47	105	6.7	46	100	6.5
2300	19	61	126	8.3	59	125	8.0	57	124	7.8
	18	57	120	7.8	54	119	7.5	53	116	7.3
	17	52	113	7.2	50	111	7.0	48	107	6.8
2200	19	59	124	8.1	57	123	7.8	55	121	7.6
	18	55	118	7.5	53	115	7.3	51	112	7.1
	17	50	110	7.0	48	107	6.8	46	103	6.6
2100	19	57	121	7.8	55	119	7.5	53	117	7.3
	18	52	114	7.3	50	112	7.1	49	108	6.9
	17	48	106	6.8	46	102	6.6	45	98	6.4

Figure 5-8. Cruise Performance (Sheet 6 of 6)

## RANGE PROFILE

### 45 MINUTES RESERVE 44 GALLONS USABLE FUEL

**CONDITIONS:**

2650 Pounds  
Recommended Lean Mixture for Cruise  
Standard Temperature  
Zero Wind

**NOTE:**

This chart allows for the fuel used for engine start, taxi, takeoff and climb, and the distance during a normal climb up to 8000 feet and maximum climb above 8000 feet.

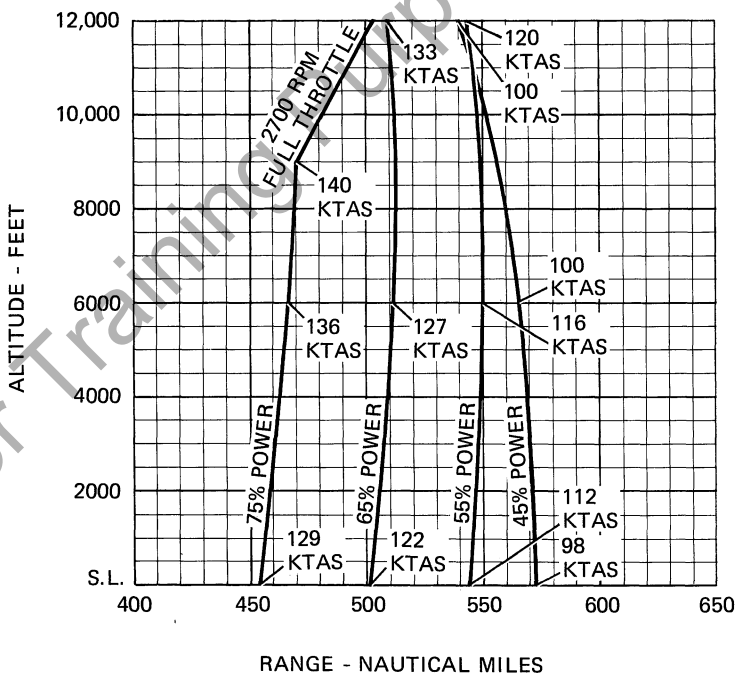

Figure 5-9. Range Profile (Sheet 1 of 2)

## RANGE PROFILE 45 MINUTES RESERVE 62 GALLONS USABLE FUEL

CONDITIONS:  
2650 Pounds  
Recommended Lean Mixture for Cruise  
Standard Temperature  
Zero Wind:

NOTE:  
This chart allows for the fuel used for engine start, taxi, takeoff and climb, and the distance during a normal climb up to 8000 feet and maximum climb above 8000 feet.

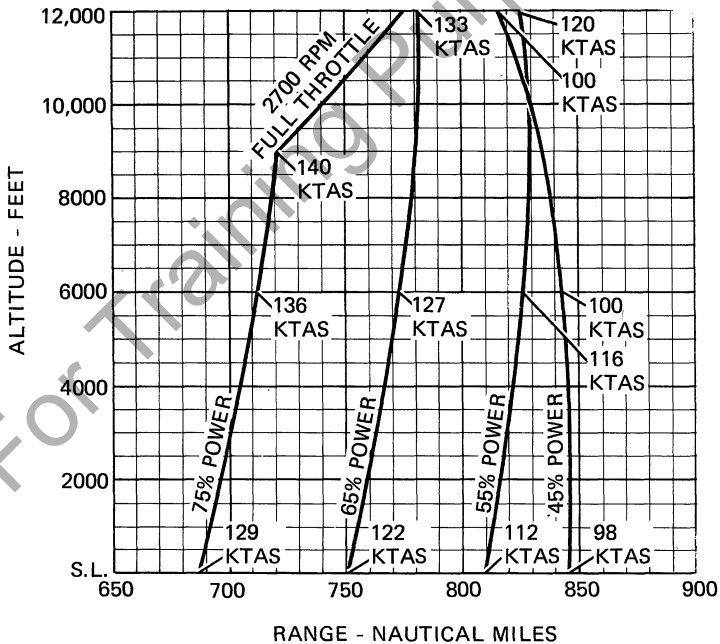

Figure 5-9. Range Profile (Sheet 2 of 2)



## ENDURANCE PROFILE

45 MINUTES RESERVE  
44 GALLONS USABLE FUEL

CONDITIONS:  
2650 Pounds  
Recommended Lean Mixture for Cruise  
Standard Temperature

NOTE:  
This chart allows for the fuel used for engine start, taxi, takeoff and climb, and the time during a normal climb up to 8000 feet and maximum climb above 8000 feet.

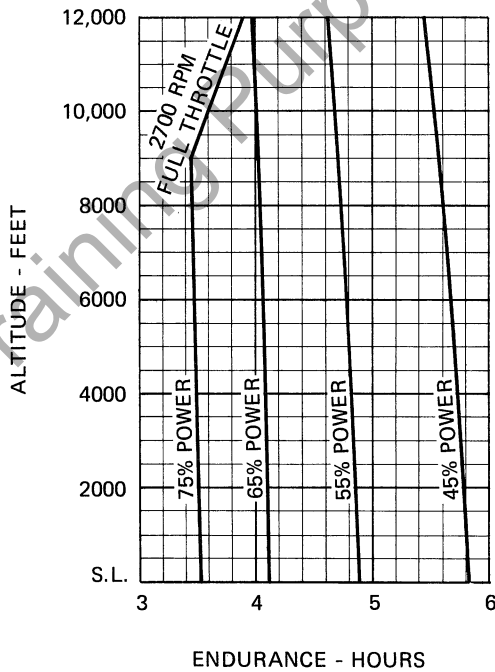

Figure 5-10. Endurance Profile (Sheet 1 of 2)

## ENDURANCE PROFILE

45 MINUTES RESERVE  
62 GALLONS USABLE FUEL

CONDITIONS:

2650 Pounds  
Recommended Lean Mixture for Cruise  
Standard Temperature

NOTE:

This chart allows for the fuel used for engine start, taxi, takeoff and climb, and the time during a normal climb up to 8000 feet and maximum climb above 8000 feet.

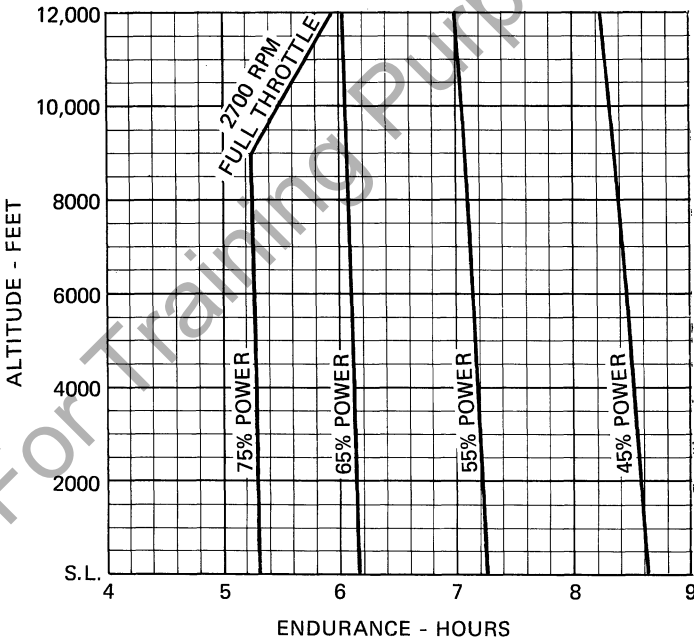

Figure 5-10. Endurance Profile (Sheet 2 of 2)

# LANDING DISTANCE

## SHORT FIELD

**CONDITIONS:**

- Flaps 30°
- Power Off
- Maximum Braking
- Paved, Level, Dry Runway
- Zero Wind

**NOTES:**

1. Short field technique as specified in Section 4.
2. Decrease distances 10% for each 9 knots headwind. For operation with tailwinds up to 10 knots, increase distances by 10% for each 2 knots.
3. For operation on a dry, grass runway, increase distances by 40% of the "ground roll" figure.
4. If a landing with flaps up is necessary, increase the approach speed by 9 KIAS and allow for 35% longer distances.

WEIGHT LBS	SPEED AT 50 FT KIAS	PRESS ALT FT	0°C		10°C		20°C		30°C		40°C	
			GRND ROLL FT	TOTAL FT TO CLEAR 50 FT OBS	GRND ROLL FT	TOTAL FT TO CLEAR 50 FT OBS	GRND ROLL FT	TOTAL FT TO CLEAR 50 FT OBS	GRND ROLL FT	TOTAL FT TO CLEAR 50 FT OBS	GRND ROLL FT	TOTAL FT TO CLEAR 50 FT OBS
2650	63	S.L.	590	1290	615	1325	635	1355	660	1395	680	1425
		1000	615	1325	635	1355	660	1395	680	1425	705	1460
		2000	635	1355	660	1395	685	1430	705	1465	730	1500
		3000	660	1395	685	1430	710	1470	735	1505	760	1545
		4000	685	1430	710	1470	735	1510	760	1545	785	1585
		5000	710	1470	740	1515	765	1550	790	1590	815	1630
		6000	740	1515	765	1555	795	1595	820	1635	850	1680
		8000	770	1560	795	1600	825	1645	855	1690	885	1735

Figure 5-11. Landing Distance

For Training Purposes Only

# SECTION 6 WEIGHT & BALANCE/ EQUIPMENT LIST

## TABLE OF CONTENTS

	Page
Introduction . . . . .	6-3
Airplane Weighing Procedures . . . . .	6-3
Weight And Balance . . . . .	6-6
Baggage Tie-Down . . . . .	6-6
Equipment List . . . . .	6-15

For Training Purposes Only

For Training Purposes Only

## INTRODUCTION

This section describes the procedure for establishing the basic empty weight and moment of the airplane. Sample forms are provided for reference. Procedures for calculating the weight and moment for various operations are also provided. A comprehensive list of all Cessna equipment available for this airplane is included at the back of this section.

It should be noted that specific information regarding the weight, arm, moment and installed equipment for this airplane as delivered from the factory can only be found in the plastic envelope carried in the back of this handbook.

It is the responsibility of the pilot to ensure that the airplane is loaded properly.

## AIRPLANE WEIGHING PROCEDURES

1. Preparation:
  - a. Inflate tires to recommended operating pressures.
  - b. Remove fuel tank sump quick-drain fittings and use sampler cup at quick-drain valve in fuel selector to drain all fuel.
  - c. Service engine oil as required to obtain a normal full indication (8 quarts on dipstick).
  - d. Move sliding seats to the most forward position.
  - e. Raise flaps to the fully retracted position.
  - f. Place all control surfaces in neutral position.
2. Leveling:
  - a. Place scales under each wheel (minimum scale capacity, 1000 pounds).
  - b. Deflate the nose tire and/or lower or raise the nose strut to properly center the bubble in the level (see figure 6-1).
3. Weighing:
  - a. With the airplane level and brakes released, record the weight shown on each scale. Deduct the tare, if any, from each reading.
4. Measuring:
  - a. Obtain measurement A by measuring horizontally (along the airplane center line) from a line stretched between the main wheel centers to a plumb bob dropped from the firewall.
  - b. Obtain measurement B by measuring horizontally and parallel to the airplane center line, from center of nose wheel axle, left side, to a plumb bob dropped from the line between the main wheel centers. Repeat on right side and average the measurements.
5. Using weights from item 3 and measurements from item 4, the airplane weight and C.G. can be determined.
6. Basic Empty Weight may be determined by completing figure 6-1.

SECTION 6  
WEIGHT & BALANCE/  
EQUIPMENT LIST

CESSNA  
MODEL 172RG

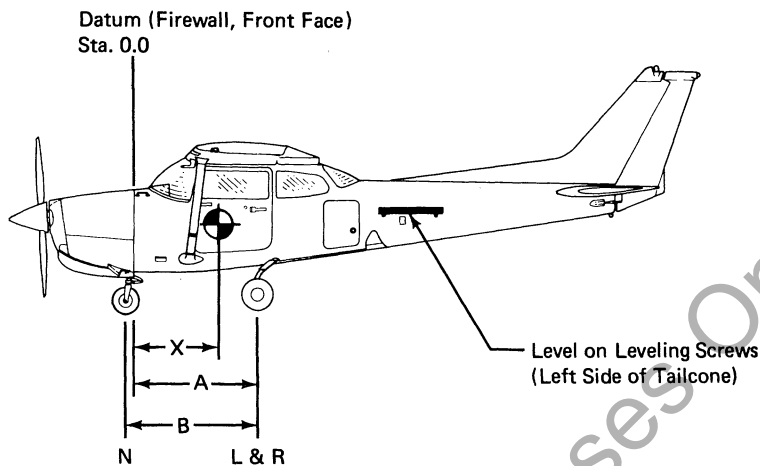

Scale Position	Scale Reading	Tare	Symbol	Net Weight
Left Wheel			L	
Right Wheel			R	
Nose Wheel			N	
Sum of Net Weights (As Weighed)			W	

$$X = \text{ARM} = \frac{(A) - (N) \times (B)}{W}; X = ( \quad ) - ( \quad ) \times ( \quad ) = ( \quad ) \text{ IN.}$$

Item	Weight (Lbs.)	X C.G. Arm (In.)	Moment/1000 (Lbs.-In.)
Airplane Weight (From Item 5, Page 6-3)			
Add Unusable Fuel: (4 Gal at 6 Lbs/Gal)	24.0	46.0	1.1
Equipment Changes			
Airplane Basic Empty Weight			

Figure 6-1. Sample Airplane Weighing





## WEIGHT AND BALANCE

The following information will enable you to operate your Cessna within the prescribed weight and center of gravity limitations. To figure weight and balance, use the Sample Problem, Loading Graph, and Center of Gravity Moment Envelope as follows:

Take the basic empty weight and moment from appropriate weight and balance records carried in your airplane, and enter them in the column titled YOUR AIRPLANE on the Sample Loading Problem.

### NOTE

In addition to the basic empty weight and moment noted on these records, the C.G. arm (fuselage station) is also shown, but need not be used on the Sample Loading Problem. The moment which is shown must be divided by 1000 and this value used as the moment/1000 on the loading problem.

Use the Loading Graph to determine the moment/1000 for each additional item to be carried; then list these on the loading problem.

### NOTE

Loading Graph information for the pilot, passengers and baggage is based on seats positioned for average occupants and baggage loaded in the center of the baggage areas as shown on the Loading Arrangements diagram. For loadings which may differ from these, the Sample Loading Problem lists fuselage stations for these items to indicate their forward and aft C.G. range limitations (seat travel and baggage area limitation). Additional moment calculations, based on the actual weight and C.G. arm (fuselage station) of the item being loaded, must be made if the position of the load is different from that shown on the Loading Graph.

Total the weights and moments/1000 and plot these values on the Center of Gravity Moment Envelope to determine whether the point falls within the envelope, and if the loading is acceptable.

## BAGGAGE TIE-DOWN

A nylon baggage net having six tie-down straps is provided as standard equipment to secure baggage on the cabin floor aft of the rear seat (baggage area 1) and on the top of the wheel well (baggage area 2). Six

eyebolts serve as attaching points for the net. Two eyebolts for the forward tie-down straps are mounted on the cabin floor near each sidewall just forward of the baggage door approximately at station 90; two eyebolts are installed near the top of the forward surface of the wheel well slightly inboard of each sidewall approximately at station 108; and two eyebolts are located on the bulkhead below the aft window near each sidewall approximately at station 108.

When the cabin floor (baggage area 1) only is utilized for baggage, the two floor-mounted eyebolts and the two eyebolts on the forward surface of the wheel well (or the two eyebolts below the aft window) may be used, depending on the height of the baggage. When baggage is carried on the wheel well (baggage area 2), the eyebolts on the forward surface of the wheel well and the eyebolts below the aft window should be used. When baggage is loaded in both areas, all six eyebolts should be utilized.

A placard on the baggage door defines the weight limitations in the baggage areas.

## LOADING ARRANGEMENTS

\*Pilot or passenger center of gravity on adjustable seats positioned for average occupant. Numbers in parentheses indicate forward and aft limits of occupant center of gravity range.

\*\*Arm measured to the center of the areas shown.

- NOTES:
1. The usable fuel C.G. arm is located at station 48.0.
  2. The rear cabin wall (approximate station 108) or aft baggage wall (approximate station 124) can be used as convenient interior reference points for determining the location of baggage area fuselage stations.

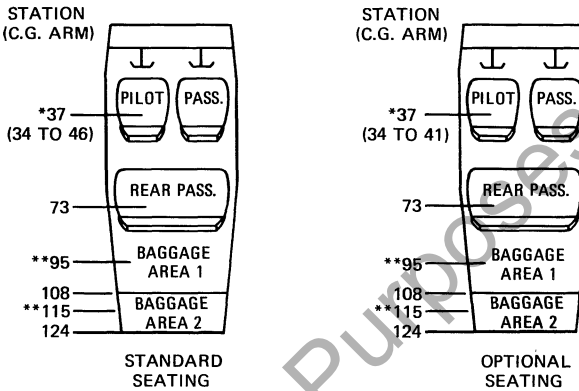
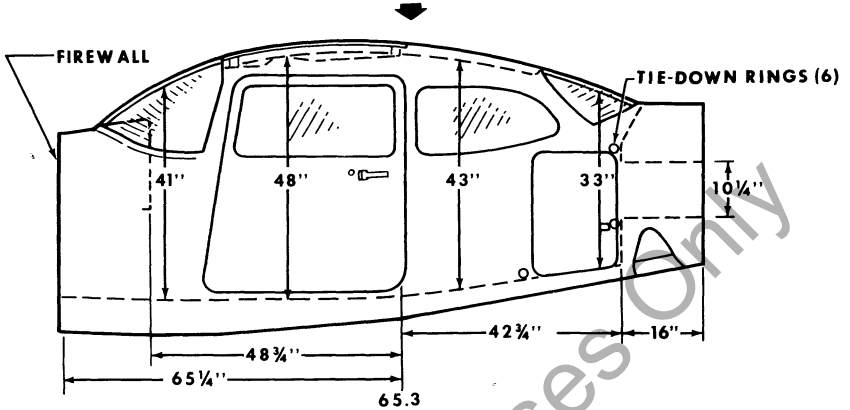

Figure 6-3. Loading Arrangements

**CABIN HEIGHT MEASUREMENTS**



**DOOR OPENING DIMENSIONS**

	WIDTH (TOP)	WIDTH (BOTTOM)	HEIGHT (FRONT)	HEIGHT (REAR)
CABIN DOOR	32"	37"	40 1/2"	39"
BAGGAGE DOOR	15 1/4"	15 1/4"	22"	21"

== WIDTH ==  
● LWR WINDOW LINE  
\* CABIN FLOOR

**CABIN WIDTH MEASUREMENTS**

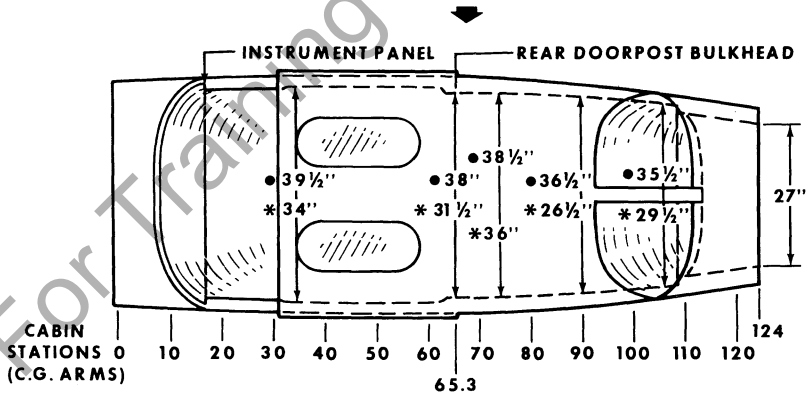

Figure 6-4. Internal Cabin Dimensions

SECTION 6  
WEIGHT & BALANCE/  
EQUIPMENT LIST

CESSNA  
MODEL 172RG

SAMPLE LOADING PROBLEM	SAMPLE AIRPLANE		YOUR AIRPLANE	
	Weight (lbs.)	Moment (lb.-ins. /1000)	Weight (lbs.)	Moment (lb.-ins. /1000)
1. Basic Empty Weight (Use the data pertaining to your airplane as it is presently equipped. Includes unusable fuel and full oil) . . . . .	1664	63.1		
2. Usable Fuel (At 6 Lbs./Gal.) Standard Tanks (62 Gal. Maximum) . . . . .				
Reduced Fuel (44 Gal.) . . . . .	264	12.7		
3. Pilot and Front Passenger (Station 34 to 46) . . . . .	340	12.6		
4. Rear Passengers . . . . .	340	24.8		
5. * Baggage Area 1 (Station 82 to 108 - 200 Lbs. Max.) . . . . .	50	4.8		
6. * Baggage Area 2 (Station 108 to 124 - 50 Lbs. Max.) . . . . .				
7. RAMP WEIGHT AND MOMENT	2658	118.0		
8. Fuel allowance for engine start, taxi, and runup	-8	-.4		
9. TAKEOFF WEIGHT AND MOMENT (Subtract Step 8 from Step 7)	2650	117.6		
10. Locate this point (2650 at 117.6) on the Center of Gravity Moment Envelope, and since this point falls within the envelope, the loading is acceptable.  *The maximum allowable combined weight capacity for baggage areas 1 and 2 is 200 pounds.				

Figure 6-5. Sample Loading Problem (Sheet 1 of 2)



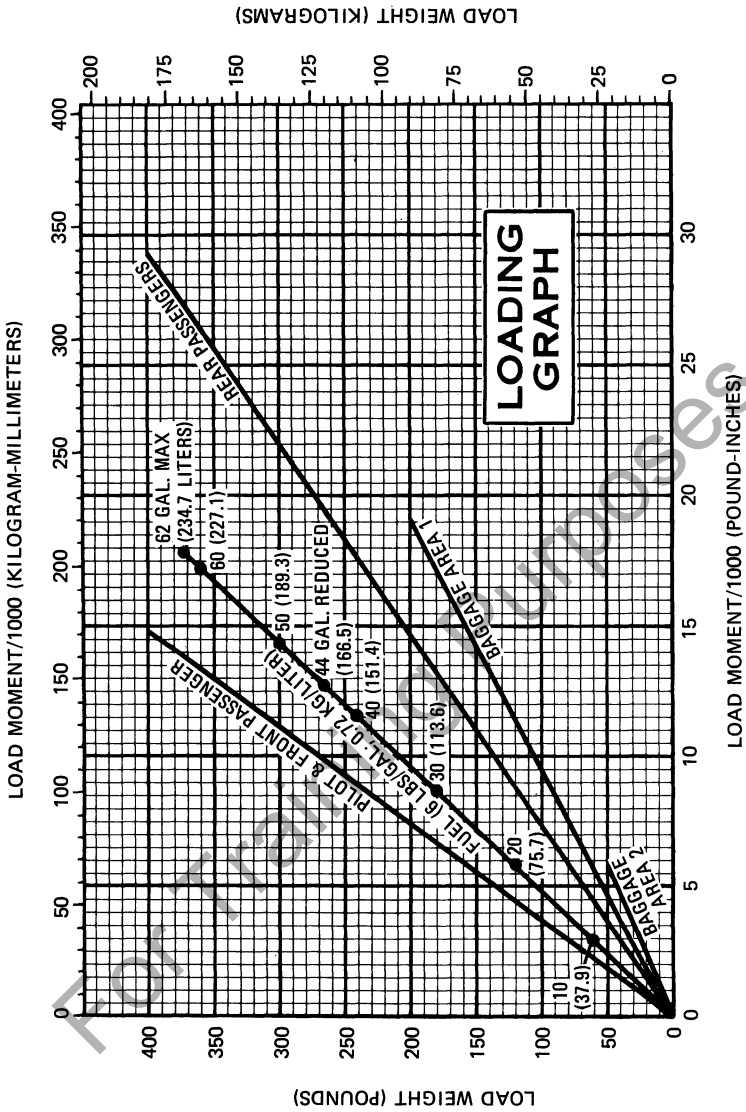

NOTES: Line representing adjustable seats shows the pilot or passenger center of gravity on adjustable seats positioned for an average occupant. Refer to the Loading Arrangements diagram for forward and aft limits of occupant C.G. range.

Figure 6-6. Loading Graph



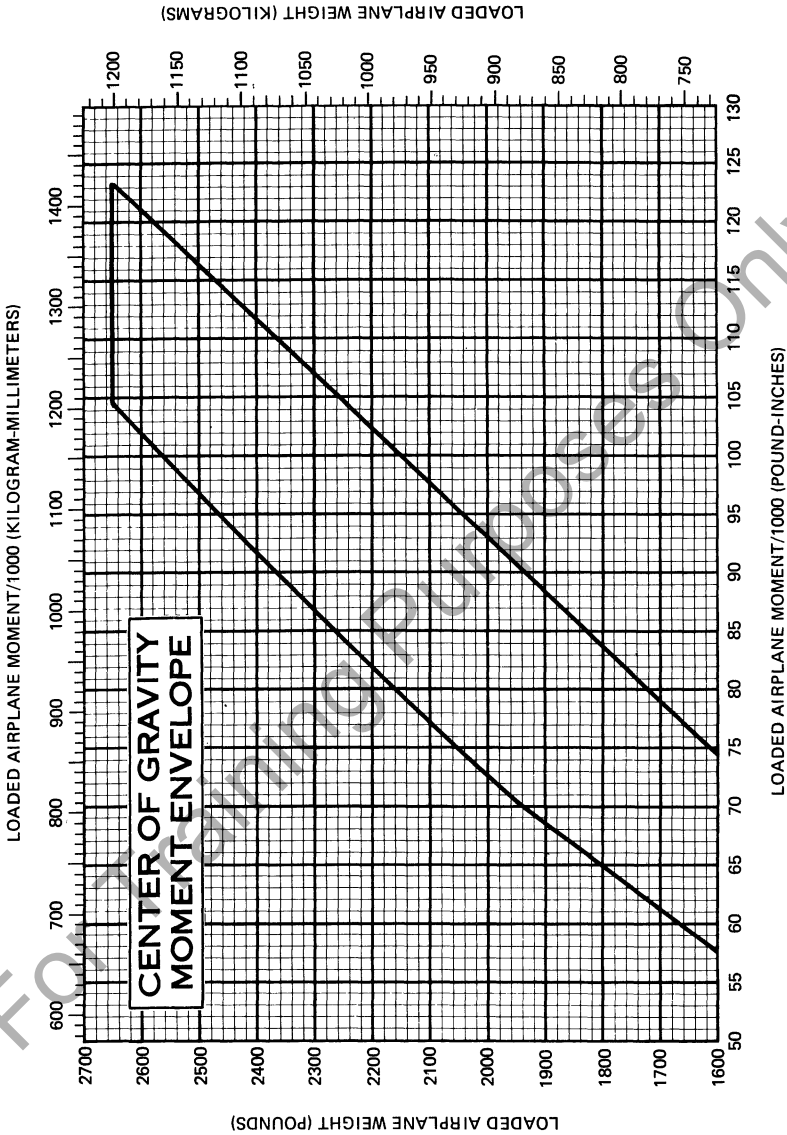

Figure 6-7. Center of Gravity Moment Envelope

SECTION 6  
WEIGHT & BALANCE/  
EQUIPMENT LIST

CESSNA  
MODEL 172RG

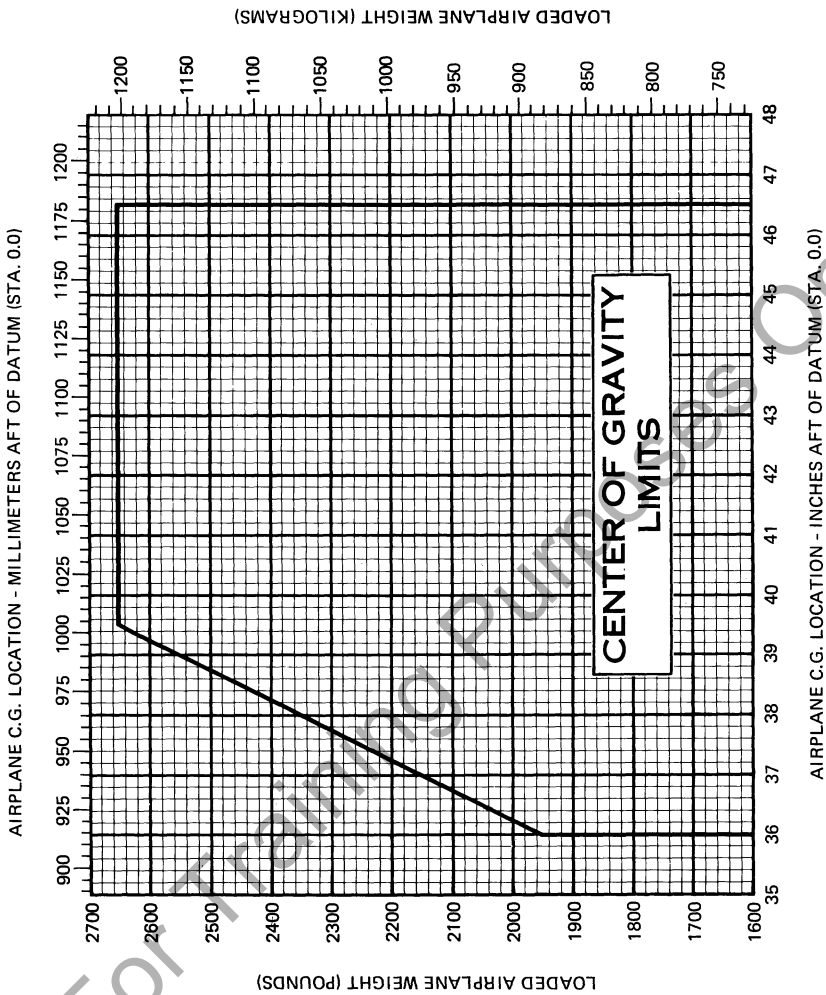

Figure 6-8. Center of Gravity Limits

## EQUIPMENT LIST

The following equipment list is a comprehensive list of all Cessna equipment available for this airplane. A separate equipment list of items installed in your specific airplane is provided in your aircraft file. The following list and the specific list for your airplane have a similar order of listing.

This equipment list provides the following information:

An **item number** gives the identification number for the item. Each number is prefixed with a letter which identifies the **descriptive** grouping (example: A. Powerplant & Accessories) under which it is listed. Suffix letters identify the equipment as a required item, a standard item or an optional item. Suffix letters are as follows:

- R = required items of equipment for FAA certification
- S = standard equipment items
- O = optional equipment items replacing required or standard items
- A = optional equipment items which are in addition to required or standard items

A **reference drawing** column provides the drawing number for the item.

### NOTE

If additional equipment is to be installed, it must be done in accordance with the reference drawing, accessory kit instructions, or a separate FAA approval.

Columns showing **weight (in pounds)** and **arm (in inches)** provide the weight and center of gravity location for the equipment.

### NOTE

Unless otherwise indicated, true values\* (not net change values) for the weight and arm are shown. Positive arms are distances aft of the airplane datum; negative arms are distances forward of the datum.

### NOTE

Asterisks (\*) after the item weight and arm indicate complete assembly installations. Some major components of the assembly are listed on the lines immediately following. The summation of these major components does not necessarily equal the complete assembly installation.

SECTION 6  
WEIGHT & BALANCE/  
EQUIPMENT LIST

CESSNA  
MODEL 172RG

ITEM NO	EQUIPMENT LIST DESCRIPTION	REF DRAWING	WT LBS	ARM INS
	A. POWERPLANT & ACCESSORIES			
A01-R	ENGINE, LYCOMING O-360-F1A6 (INCLUDED ELECTRIC STARTER, VACUUM PAD, 8 SPARK PLUGS, TWO MAGNETOS AND OIL FILTER)	245000-1	303.5	-22.5
A05-R	FILTER, CARBURETOR AIR	C294510-0501	1.2	-11.0
A09-R	ALTERNATOR, 28 V 60 AMP.	C611503-0102	10.7	-32.0
A33-R	PROPELLER, CONSTANT SPEED	C161008-0111	53.2	-43.7
A37-R	GOVERNOR, PROPELLER	C161031-0112	2.7	-32.5
A41-R	SPINNER INSTALLATION -SPINNER DOME	2450002 2450004-1	4.1* 2.0	-43.8* -46.4
A61-S	VACUUM SYSTEM INSTALLATION -VACUUM PUMP -FILTER INSTL -VACUUM GAUGE -RELIEF VALVE -LOW WARNING LIGHT	2406001 C431003-0101 1201075 C668509-0101 C482001-0401 S-2571	3.0* 1.8 0.3 0.1 0.4 0.1	-2.3* -10.7 4.7 16.2 14.5 17.5
A70-S	PRIMER SYSTEM, ENGINE (3 CYLINDER)	2450000-2	0.5	-12.0
A73-O	OIL QUICK DRAIN VALVE (NET CHANGE)	1701015-2	NEGL	--
	B. LANDING GEAR & ACCESSORIES			
B01-R	WHEEL, BRAKE & TIRE, 15X6.00X6 MAIN (2) -WHEEL ASSEMBLY (EACH) -BRAKE ASSEMBLY (EACH) -TIRE, 6-PLY BLACK (EACH) -TUBE (EACH)	C163019B0203 C163006-0101 C163030 C262006-0101 C262026-0101	33.8* 7.6 1.9 6.1 1.3	58.5* 59.0 54.5 59.0 59.0
B04-R	WHEEL & TIRE ASSY., 5.00X5 NOSE	C163018-0104	10.4*	-4.9*

ITEM NO	EQUIPMENT LIST DESCRIPTION	REF DRAWING	WT LBS	ARM INS
	-WHEEL ASSY., MCCAULLY -TIRE, 6-PLY BLACKWALL -TUBE	C163005-0201 C262003-0202 C262023-0101	3.8 5.2 1.4	-4.9 -4.9 -4.9
	C. ELECTRICAL SYSTEMS			
C01-R	BATTERY, 24 VOLT (STD CAPACITY)	C614002-0101	23.2	130.0
C01-O	BATTERY, 24 VOLT (HEAVY DUTY)	C614002-0102	25.2	130.0
C04-R	ALTERNATOR CONTROL UNIT, 28 VOLT W/HIGH PROTECTION & LOW SENSING	C611005-0101	0.4	3.4
C07-A	GROUND SERVICE PLUG RECEPTACLE	2401005-1	2.7	126.0
C16-O	HEATED PITOT SYS. (NET CHANGE)	2401004-1	0.6	24.4
C22-A	LIGHT INSTAL., INSTRUMENT POST	2413142-1	0.5	17.3
C25-A	MAP LIGHT INSTL. CONTROL WHEEL MOUNTED, (REQUIRES WITH E89-O)	--	0.2	21.5
C28-S	LIGHT INSTL., MAP & INSTRUMENT PANEL FLOOD (DOORPOST MOUNTED)	0700149	0.3	32.0
C31-A	LIGHT INSTALLATION, COURTESY (SET OF 2)	0521101-1	0.5	61.0
C40-A	DETECTORS, NAVIGATION LIGHT (SET OF TWO)	0701013-1,-2	NEGL	--
C43-A	LIGHT INSTALLATION, OMNIFLASH BEACON -BEACON LIGHT, IN FIN TIP -POWER SUPPLY IN VERTICAL FIN -RESISTOR - MEMCOR (7174) -WIRING & MISC. HARDWARE	2406002-1 C621001-0102 C594502-0102 DR95-6	1.4* 0.4 0.6 0.2 0.2	204.7* 242.5 205.1 208.3 124.3
C46-A	LIGHT INSTALLATION, WING TIP STROBE -POWER SUPPLY (SET OF 2) -STROBE LIGHTS (SET OF 2) -WIRING & MISC. HARDWARE	0501027-5 C622008-0102 C622006-0107	3.4* 2.3 0.2 0.9	43.3* 47.0 40.8 33.8

SECTION 6  
WEIGHT & BALANCE/  
EQUIPMENT LIST

CESSNA  
MODEL 172RG

ITEM NO	EQUIPMENT LIST DESCRIPTION	REF DRAWING	WT LBS	ARM INS
C49-S	LANDING & TAXI LIGHT INSTL., WING MOUNTED -LAMP 250 WATT (G.E.) -LAMP 250 WATT (G.E.) -BRACKETS, WIRING & HARDWARE  D. INSTRUMENTS	4596 4587	2.2* 0.5 0.5 1.2	25.3* 29.0 29.0 22.2
D01-R	INDICATOR, AIRSPEED	C661064-0108	0.6	16.0
D01-O	INDICATOR, TRUE AIRSPEED	2401012-1	0.7	16.3
D04-A	STATIC AIR, ALTERNATE SOURCE	0501017-1	0.2	15.5
D07-R	ALTIMETER, SENSITIVE (INCHES OF MERCURY)	C661071-0101	0.9	14.0
D07-O-1	ALTIMETER, (FEET AND MILLIBARS) (SENSITIVE WITH 50 FT MARKINGS)	C661071-0102	0.8	14.0
D07-O-2	ALTIMETER, (FEET AND MILLIBARS) (SENSITIVE WITH 20 FT MARKINGS)	C661025-0102	0.7	14.0
D10-A	ALTIMETER INSTALLATION - DUAL	2001015	0.8	14.0
D16-A-1	ENCODING ALTIMETER, (REQUIRES RELOCATION OF REG. ALTIMETER)	0501049-1	3.0	14.8
D16-A-2	ALTITUDE ENCODER, (BLIND, DOES NOT REQUIRE INSTRUMENT PANEL MOUNTING) -ENCODER	2401009-1 C744001-0101	1.5* 1.3	14.4* 14.6
D22-A	GAGE, CARBURETOR AIR TEMPERATURE	2401019-1	1.0	14.0
D25-S	CLOCK, ELECTRIC	C664508-0102	0.3	16.3
D25-O	CLOCK ELECTRONIC, DIGITAL READ-OUT	C664511-0101	0.3	16.3
D28-R	COMPASS INSTALLATION, (MAGNETIC)	0513262	0.5	26.0

ITEM NO	EQUIPMENT LIST DESCRIPTION	REF DRAWING	WT LBS	ARM INS
D38-R	INSTRUMENT CLUSTER, LH & RH FUEL	C669562-0101	0.4	16.2
D41-R	INSTRUMENT CLUSTER, CYL. HEAD & OIL TEMP.	C669561-0101	0.4	16.2
D43-R	INSTRUMENT CLUSTER, AMMETER & OIL PRES.	*C669560-0101	0.4	16.2
D49-A	INDICATOR, ECONOMY MIXTURE (E.G.T.)	2401008-1	0.6	7.8
D55-R	GAGE, MANIFOLD PRESSURE & FUEL FLOW	C662035-0104	0.9	16.5
D64-S	GYRO INSTALLATION, NON NAV-G-MATIC -DIRECTIONAL INDICATOR -ATTITUDE INDICATOR -HOSES & MISC HARDWARE	2406001-1 C661075-0104 C661076-0101	5.7* 2.5 1.9 1.4	12.4* 13.5 14.5 14.7
D64-0	GYRO INSTALLATION, 300 NAV-G-MATIC -DIRECTIONAL IND (ARC) -ATTITUDE INDICATOR -HOSES & MISC HARDWARE	2406001-2 40760-0104 C661076-0101	6.0* 2.7 1.9 1.4	12.5* 13.5 14.5 14.7
D67-A	RECORDER, FLIGHT HOUR	2401014-1	0.5	6.3
D82-S	GAGE, OUTSIDE AIR TEMP	0500221	0.1	28.6
D85-R	TACHOMETER INSTALLATION -RECORDING TACH HEAD	2406000 C668020-0124	1.0* 0.6	13.0* 15.5
D88-S-1	INDICATOR, TURN COORDINATOR, 28 VOLT ONLY	C661003-0507	1.8	15.8
D88-S-2	INDICATOR, TURN COORDINATOR, 10 - 30 VOLT	C661003-0506	1.0	15.8
D88-0	INDICATOR, TURN COORDINATOR, (AUTOPILOT)	42320-0028	1.2	15.8
D91-S	INDICATOR, VERTICAL SPEED	C661080-0101	0.8	15.7
E05-R	E. CABIN ACCOMMODATIONS  SEAT, ADJUST. FORE & AFT, PILOT	0514203-1	16.3	44.0

\* C669560-0108 on airplanes modified by Service Kit SK172-85.

SECTION 6  
WEIGHT & BALANCE/  
EQUIPMENT LIST

CESSNA  
MODEL 172RG

ITEM NO	EQUIPMENT LIST DESCRIPTION	REF DRAWING	WT LBS	ARM INS
E05-0	SEAT, INFINITE ADJUSTING, PILOT	0514204-1	23.0	41.5
E07-S	SEAT, ADJ. FORE & AFT, CO-PILOT	0514203-1	16.3	44.0
E07-0	SEAT, INFINITE ADJUST, CO-PILOT	0514204-2	23.0	41.5
E09-S	SEAT REAR, 2 PIECE BACK CUSHION	0514202-2	25.6	79.5
E15-R	BELT ASSEMBLY, FOR PILOT LAP	S-2275-103	1.0	37.0
E15-S	SHOULDER HARNESS ASSY., PILOT	S-2275-201	0.6	37.0
E19-0	INERTIA REEL - SEAT BELT INSTL; PILOT AND CO-PILOT (NET CHANGE)	S2577-5,-6	2.0	82.0
E23-S	BELT & SHOULDER ASSY., CO-PILOT	S-2275-3	1.6	37.0
E27-S	BELTS ASSEMBLY, REAR (SET OF 2)	S-1746-13	2.0	70.0
E27-0	BELT & SHOULDER ASSY 2ND ROW (2)	S-2275-8	3.2	70.0
E33-0	CARPETING, BLACK (EXCHG FOR STD)		NEGL	--
E34-0-1	DELUXE GLARESHIELD (NET CHANGE)	0515034-1	1.0	21.0
E34-0-2	SIDE PANEL COVERING, LEATHER (NET CHG)		1.0	63.0
E35-A-1	SEAT COVERING, VINYL (NET CHG.)		NEGL	--
E35-A-2	SEAT COVERING, LEATHER (NET CHG)	CES-1151	2.0	62.0
E36-A	FLOORMATS, REMOVABLE (2)	0501120-1	3.8	20.5
E37-A	WINDOW, RH DOOR HINGED (NET CHG)	0501107-2	2.3	47.0
E39-A	WINDOW, OVERHEAD CABIN (NET CHG)	0511800-12	0.9	47.9
E43-A	VENTILATION SYSTEM, AT REAR SEAT	0700322-15	1.8	50.9
E49-A	CUP HOLDERS, BEVERAGE (SET OF 2)	0715083-1	0.1	15.5
E50-A	HEADRESTS, FRONT SEAT (SET OF 2)	1215073-11	1.5	47.0



ITEM NO	EQUIPMENT LIST DESCRIPTION	REF DRAWING	WT LBS	ARM INS
E51-A	HEADRESTS, REAR SEAT (SET OF 2)	1215073-11	1.5	86.0
E55-S	SUN VISORS (SET OF 2)	0514166-1	0.9	32.8
E57-O	TINTED GLASS, CABIN, (NET CHG.)	0500267-4	0.0	--
E59-A	APPROACH PLATE HOLDER INSTL.	0415044-2	0.1	20.5
E65-R	BAGGAGE NET, TIE DOWN	2015009-8	0.5	95.0
E65-A	DUAL CONTROL INSTALLATION, INCLUDES-- CO-PILOT'S WHEEL, PEDALS & TIE BRAKES -CONTROL WHEEL W/PADDING -RUDDER PEDAL (SET OF 2)	2401007-1 0415030-1 2467000-1	5.5 2.0 1.1	12.4* 26.0 6.8
E87-S	RUDDER TRIM SYSTEM INSTL.	0513290	1.9	9.4
E89-O-1	CONTROL WHEEL, ALL PURPOSE, PILOT (INCLUDED MIKE SW & PANEL MOUNTED AUXILIARY MIKE JACK) (NET CHANGE)	0501068-4	NEGL	--
E89-O-2	CONTROL WHEEL W/MIKE ATTACH	2401035-1	NEGL	--
E89-O-3	LARGE CONTROL WHEEL INSTL. (NET CHG)		1.6	22.0
F01-R	F. PLACARDS, WARNINGS & MANUALS			
F01-O-1	PLACARD, OPERATIONAL LIMITATIONS VFR DAY PLACARD, OPERATIONAL LIMITATIONS VFR DAY- NIGHT	0505087 0505087	NEGL NEGL	-- --
F01-O-2	PLACARD, OPERATIONAL LIMITATIONS IFR DAY- NIGHT	0505087	NEGL	--
F07-R	STALL AND GEAR, WARNING BLACKBOX RQS--H61-R FOR AUDIBLE OPERATION	2401004-1	0.5	39.1

SECTION 6  
WEIGHT & BALANCE/  
EQUIPMENT LIST

CESSNA  
MODEL 172RG

ITEM NO	EQUIPMENT LIST DESCRIPTION	REF DRAWING	WT LBS	ARM INS
F10-S	PILOT'S CHECKLIST, STOWED (LOCATED IN GLOVE BOX)	D6106	0.3	14.5
F16-R	PILOT'S OPERATING HANDBOOK & FAA APPROVED AIRPLANE FLIGHT MANUAL (LOCATED AT BACK OF PILOT SEAT)	D1232-13PH	1.1	47.8
	G. AUXILIARY EQUIPMENT			
G07-A	HOISTING RINGS, (CABIN TOP)	0541115-1	1.1	49.1
G13-A	CORROSION PROOFING, INTERNAL	2401006-1	12.9	77.0
G16-A	STATIC DISCHARGER, SET OF 10	0501048-1	0.4	143.2
G19-A	ABRASION BOOTS, (STABILIZER)	0500041-3	2.7	206.0
G22-S	TOW BAR	0501019-1	1.7	87.0
G25-S	PAINT OVERALL EXTERIOR COVER -WHITE BASE, OVERALL -STRIPE COLOR SCHEME	2404004	12.6* 12.0 0.6	92.8* 90.5 139.0
G31-A	CABLES, CORROSION RESISTANT (NET CHANGE)	0500036	NEGL	--
G55-A	FIRE EXTINGUISHER INSTL., (GENERAL CORP) -FIRE EXTINGUISHER -MOUNTING CLAMP	2401011-5 C421001-0201 C421001-0202	5.3* 4.8 0.5	43.8* 44.0 42.2
G58-A	STEPS AND HANDLE, REFUELING	2413123-1	1.7	17.8
G67-A	RUDDER PEDAL EXTENSION, REMOVABLE (STOWABLE - INSTALLED ARM SHOWN) AVAILABLE FROM DEALERS (SET OF 2)	0501082-1	2.3	8.0
G88-A	WINTERIZATION KIT INSTALLATION, ENGINE -COVER PLATE, FWD COWL (INSTL.) -COVER PLATE, FWD COWL (STOWED)	2401020-1 -- --	1.0* 0.4 0.4	-24.3* -32.0 95.0

ITEM NO	EQUIPMENT LIST DESCRIPTION	REF DRAWING	WT LBS	ARM INS
H01-A	H. AVIONICS & AUTOPILOTS  CESSNA 300 ADF INSTALLATION, W/BFO -RECEIVER, P-546E -INDICATOR, IN-346A -SENSE ANT. INSTAL. -LOOP ANT. INSTAL. -WIRING & HARDWARE	3910159-25 41240-0001 40980-1001 0570400-632 3960104-1	6.9* 3.3 0.9 0.2 1.4 1.1	22.3* 13.1 14.1 101.8 59.3 20.8
H04-A	COLLINS DME-451 INSTALLATION -INDICATOR, IND-45CC -TRANSMITTER, TCR-451 -ANTENNA & MISC. ITEMS	3910213-3 622-5588-001 622-3670-001 622-4011-001	7.6* 0.9 5.3 0.2 1.2	92.3* 14.5 118.0 32.0 47.2
H05-A	COLLINS ANS-351C R-NAV INSTALLATION -INDICATOR, IN-442AR, ADDED -INDICATOR, IN-380A, DELETED -COMPUTER, R-NAV, ANS-351C -COOLING, WIRING & HARDWARE	3910214-2 43910-1000 50570-1000 622-5579-001 3930251-5	3.7* 1.0 1.8 -1.8 3.3 1.1	26.0* 14.7 14.7 14.5 47.8
H07-A	CESSNA 400 GLIDESLOPE, INCLUDES VOR/ILS INDICATOR, EXCHG FOR VOR/LOC INDICATOR -GLIDESLOPE RECEIVER, R-443B -ANTENNA COUPLER, (NET CHG.) -VOR/ILS IND., IN-381A ADDED -VOR/LOC IND., IN-380A DELETED -WIRING AND MISC. HARDWARE	3910157-18  42100-0000 52473-1 50570-2000 50570-1000	4.7*  2.1 NEGL 1.9 -1.8 2.5	89.6*  133.9 14.7 14.7 55.4
H08-A-1	AUTO RADIAL CENTERING INDICATOR, ARC/LOC EXCHANGE FOR VOR/LOC IND (300 SERIES) NAV COM 720 CH; USED WITH H22-A (WT NET CHG.) -VOR/LOC IND., IN-380AC ADDED -VOR/LOC IND., IN-380A DELETED	3910196-3  50570-1200 50570-1000	NEGL  1.8 -1.8	--  14.7 14.7
H08-A-2	AUTO RADIAL CENTERING INDICATOR, ARC/ILS EXCHANGE FOR VOR/ILS INDICATOR USED WITH ITEM H07-A 400 GLIDESLOPE, (WT NET CHG.) -ARC/ILS IND., IN-381AC ADDED -VOR/ILS IND., IN-381A DELETED	3910196-4  50570-2200 50570-2000	NEGL  1.9 -1.9	--  14.7 14.7

SECTION 6  
WEIGHT & BALANCE/  
EQUIPMENT LIST

CESSNA  
MODEL 172RG

ITEM NO	EQUIPMENT LIST DESCRIPTION	REF DRAWING	WT LBS	ARM INS
H11-A	SUNAIR ASB-125HF TRANSCEIVER, 2ND UNIT -AUDIO CONTROL PANEL -ANTENNA LOAD BOX, CU-1000A -POWER SUPPLY & SHOCK RACK -TRANSCEIVER, PANEL MOUNTED -ANTENNA INSTL. 351 IN LONG -WIRING AND MISC. HARDWARE	3910158-43 3970131-1 99816 99391 99681 3960117-3	21.9* 1.1 5.2 8.5 5.3 0.3 1.4	97.3* 15.8 127.2 140.6 141.1 170.1 102.2
H13-A	CESSNA 400 MARKER BEACON INSTALLATION -RECEIVER, R-402 -ANTENNA, L. ROD -WIRING & HARDWARE	3910164-28 51170-0000 0770681-1 3950149	2.2* 0.6 0.7 0.9	63.7* 20.7 140.0 33.0
H16-A-1	CESSNA 300 TRANSPONDER INSTALLATION -RADIO COOLING (PARTIAL) -TRANSCEIVER, RT-359A -TRANSPONDER, ANTENNA -WIRING AND HARDWARE	3910127-29 3930251-4 41420-0028 42940-0000 3950149	3.8* 0.1 0.7 0.2 0.8	17.8* 17.7 14.1 59.3 21.1
H16-A-2	CESSNA 400 TRANSPONDER INSTALLATION -TRANSCIVER, RT-459A -TRANSPONDER, ANTENNA -WIRING AND HARDWARE	3910128-28 41470-1028 42940-0000 3950149	3.8* 2.8 0.2 0.8	18.0* 14.1 59.3 21.1
H22-A	CESSNA 300 NAV/COM 720 CH COM INSTALLATION REQUIRES--H34-A TO BE OPERATIONAL, 1ST UNIT H37-A TO BE OPERATIONAL, 2ND UNIT -RECEIVER-TRANSCIVER, RT-385A -VDR/LOC INDICATOR, IN-380A -WIRING, MOUNTING AND HARDWARE	3910183-43  46660-1000 50570-1000 3950149	7.9*  5.5 1.8 0.6	13.3*  13.5 14.5 12.5
H28-A	EMERGENCY LOCATOR TRANSMITTER INSTL. -TRANSMITTER -ANTENNA -HARDWARE	0470435 C589512-0103 C589512-0106	3.0* 2.7 0.2 0.1	116.7* 116.4 122.0 114.3
H31-A-1	NAV-G-MATIC 200A INSTALLATION, AF-295B -CONTROLLER & MOUNT, CA-295B -TURN COORDINATOR (NET CHG) -A/P RELAY INSTALLATION, KIT -ROLL ACTUATOR, PA-495	3910162-25 43610-1202 42320-0028 2470016-4 42730-3908	8.4* 1.1 0.2 0.4 3.8	51.3* 13.8 15.8 4.0 68.1

ITEM NO	EQUIPMENT LIST DESCRIPTION	REF DRAWING	WT LBS	ARM INS
H31-A-2	-WIRING AND MISC. HARDWARE NAV-CONTROL 300A INSTALLATION, AF-395A -CONTROLLER-AMPLIFIER, CA-395A -D64-0 GYRO INSTL., NET CHANGE -D88-0 TURN COORD., NET CHANGE -APP RELAY INSTALLATION, PA KIT -AILERON ROLL ACTUATOR, PA-495 -WIRING AND MISC. HARDWARE	3910163-25 42660-1202 2406001-2 42320-0028 2470019-4 42730-3908 3950149-17	2.9 9.0* 1.4 0.3 0.2 0.4 3.8 2.9	52.3 48.6* 13.8 15.5 15.8 4.0 68.1 51.9
H33-A	INTERCOM SYSTEM INSTALLATION REQUIRES—E89-0 ALL PURPOSE CONTROL WHEEL E85-A DUAL CONTROL INSTALLATION -JACK FOR INTERPHONE, R.H. -H56-A HEADPHONE & WIRE (2) -INTERCOM, P/C BOARD ASSY. -CONTROL WHEEL INSTL., R.H.	3970150-2 C596531-0101 3970149-1 3970153-4	0.3 2.2 0.2 0.3	18.0 13.0 14.0 19.0
H34-A	BASIC AVIONICS KIT INSTALLATION: REQUIRES 1ST NAV/COM TO OPERATE -BLOWER & COOLING INSTALLATION -NOISE FILTER - AUDIO (ON ALT.) -LH VHF COM ANTENNA CABLE INSTL -NAV ANTENNA CABLE INSTALLATION -COM ANTENNA - STATIC NAV. ANT. -LH VHF COM ANT. INSTALLATION -MICROPHONE & MIC JACK HANDHELD -HEADPHONE & JACK, STOWED ITEM -AUDIO CONTROL PNL, INSTALLATION -STATIC KIT ANTI-PRECIPIATION	3910186-17 3930251-1,-2 3940148-2 3950149-10 3950149-8 3960142-1 3960113-1 3970124-7 3970125-4 3970152-1 0501048-1	5.0* 1.0 0.4 0.6 0.5 0.4 0.3 0.2 0.1 0.4	59.7* 2.8 -29.0 27.8 176.0 220.8 62.4 17.2 14.2 15.8 143.2
H37-A	COM ANTENNA & OMNI COUPLER KIT INSTL. -RH VHF COM ANTENNA CABLE INSTL -ANT. COUPLER (SIGNAL SPLITTER) -RH VHF COM ANT. INSTALLATION -2ND N/C TRANSCEIVER KIT INSTAL -RADIO COOLING INSTL. (PARTIAL)	3910185-15 3950149-9 3960113-12 3960113-2 3930180-4 3930251-3	1.2* 0.4 0.2 0.4 0.1 0.1	33.2* 27.0 7.0 62.4 16.5 7.1
H43-A	AVIONICS OPTION D AUTOPILOT WING PROVISION	0522632-6	1.7	68.2
H55-A	MIKE-HEADSET COMBO. INSTL (HEADSET STOWED) (REQ ALL PURPOSE CONTROL WHEEL E89-0-1,-2)	C596533-0101	0.3	13.0

SECTION 6  
WEIGHT & BALANCE/  
EQUIPMENT LIST

CESSNA  
MODEL 172RG

ITEM NO	EQUIPMENT LIST DESCRIPTION	REF DRAWING	WT LBS	ARM INS
H56-A	MICROPHONE AND HEADSET, PADDED (STOWED) (RQS ALL PURPOSE CONTROL WHEEL E89-0-1,-2)	C596531-0101	1.1	13.0
H61-R	SPEAKER & GEAR WARNING HORN (USES W/F07-R)	C596510-0101	1.9	38.5
H64-A	AVIONICS PARTIAL OPTION 'A' (EXPORT ONLY) -BLOWER COOLING INSTAL -LH CABLE OMNI ANTENNA -LH CABLE VHF INSTAL -LH ANTENNA VHF INSTAL -MICROPHONE & MIC JACK -HEADPHONE & HEAD JACK	3910206-23 3930251-1 3950149-8 3950149-10 3960113-1 3970124-7 3970125-4	2.9* 1.0 0.6 0.4 0.4 0.2 0.2	40.0* 2.4 116.0 27.8 62.4 14.2
H67-A	AVIONICS PARTIAL OPTION 'B' (EXPORT ONLY) -OPTION 'A', (INCLUDED) -RH VHF ANT, CABLE INSTL -ANTENNA COUPLER INSTL -RH VHF ANTENNA INSTL	3910206-24 3910206-23 3950149-9 3960111-12 3960113-2	3.9* 2.9 0.4 0.2 0.4	39.4* 40.0 27.8 7.0 62.4
J. SPECIAL OPTION PACKAGES				
J01-A	CUTLASS RG II EQUIPMENT CONSISTS OF ITEMS -C16-0 HEATED PITOT SYSTEM INSTL -C31-A COURTESY LIGHT INSTL (2) -C40-A NAV LIGHT DETECTOR INSTL -C43-A LIGHT INSTL FLASH BEACON -C63-A LIQ SPEED IND., (NET BECHG.) -D01-0 STATIC, ALTRNATE INSTALLATION -D04-A DUAL ADF INSTL -E85-A 300 TRANSPONDER, RT-359A -H01-A-1 NAV/COM, IN-380A -H22-A EMERGENCY LOC TRANSMITTER -H28-A BASIC AVIONICS KIT INSTL -H34-A	- 2401004-1 0521101-1 0761013-1,-2 2406002-1 2401012-1 0501017-1 2401007-1 3910159-25 3910127-29 3910183-43 0470435 3910186-17	34.9* 0.6 0.5 NEGL 1.4 0.1 0.2 5.9 6.8 3.8 7.9 3.0 5.0	39.5* 24.4 61.0 204.7 16.5 15.4 22.3 17.8 116.7 59.7
J04-A	CUTLASS RG II W/NAV-PAC CONSISTS OF ITEMS -H07-A GLIDESLOPE, R-443 INSTL -H13-A 400 MARKER BEACON INSTL -H22-A NAV/COM INSTL, 2ND UNIT -H37-A ANTENNA AND COUPLER KIT	3910157-18 3910164-28 3910183-43 3910185-15	16.0* 4.2 7.9 1.2	44.2* 89.6 63.7 13.3 33.2

# SECTION 7

## AIRPLANE & SYSTEMS DESCRIPTIONS

### TABLE OF CONTENTS

	Page
Introduction . . . . .	7-3
Airframe . . . . .	7-3
Flight Controls . . . . .	7-8
Trim Systems . . . . .	7-8
Instrument Panel . . . . .	7-8
Ground Control . . . . .	7-9
Wing Flap System . . . . .	7-10
Landing Gear System . . . . .	7-11
Landing Gear Lever . . . . .	7-11
Landing Gear Position Indicator Lights . . . . .	7-12
Landing Gear Operation . . . . .	7-12
Emergency Hand Pump . . . . .	7-13
Landing Gear Warning System . . . . .	7-13
Baggage Compartment . . . . .	7-13
Seats . . . . .	7-13
Seat Belts And Shoulder Harnesses . . . . .	7-14
Seat Belts . . . . .	7-14
Shoulder Harnesses . . . . .	7-15
Integrated Seat Belt/Shoulder Harnesses With Inertia Reels . . . . .	7-15
Entrance Doors And Cabin Windows . . . . .	7-17
Control Locks . . . . .	7-18
Engine . . . . .	7-18
Engine Controls . . . . .	7-18
Engine Instruments . . . . .	7-19
New Engine Break-In And Operation . . . . .	7-20
Engine Lubrication System . . . . .	7-20
Ignition-Starter System . . . . .	7-21
Air Induction System . . . . .	7-21
Exhaust System . . . . .	7-22
Carburetor And Priming System . . . . .	7-22
Cooling System . . . . .	7-22
Propeller . . . . .	7-23
Fuel System . . . . .	7-23

## TABLE OF CONTENTS (Continued)

	Page
Hydraulic System . . . . .	7-27
Brake System . . . . .	7-29
Electrical System . . . . .	7-29
Master Switch . . . . .	7-31
Avionics Power Switch . . . . .	7-31
Ammeter . . . . .	7-32
Alternator Control Unit And Low-Voltage Warning Light . . . . .	7-32
Circuit Breakers And Fuses . . . . .	7-32
Ground Service Plug Receptacle . . . . .	7-33
Lighting Systems . . . . .	7-33
Exterior Lighting . . . . .	7-33
Interior Lighting . . . . .	7-34
Cabin Heating, Ventilating And Defrosting System . . . . .	7-35
Pitot-Static System And Instruments . . . . .	7-37
Airspeed Indicator . . . . .	7-38
Vertical Speed Indicator . . . . .	7-38
Altimeter . . . . .	7-38
Vacuum System And Instruments . . . . .	7-38
Attitude Indicator . . . . .	7-40
Directional Indicator . . . . .	7-40
Suction Gage . . . . .	7-40
Low-Vacuum Warning Light . . . . .	7-40
Stall Warning System . . . . .	7-41
Avionics Support Equipment . . . . .	7-41
Avionics Cooling Fan . . . . .	7-41
Microphone - Headset Installations . . . . .	7-41
Static Dischargers . . . . .	7-42



## INTRODUCTION

This section provides description and operation of the airplane and its systems. Some equipment described herein is optional and may not be installed in the airplane. Refer to Section 9, Supplements, for details of other optional systems and equipment.

## AIRFRAME

The airplane is an all-metal, four-place, high-wing, single-engine airplane equipped with retractable tricycle landing gear and designed for general utility purposes.

The construction of the fuselage is a conventional formed sheet metal bulkhead, stringer, and skin design referred to as semimonocoque. Major items of structure are the front and rear carry-through spars to which the wings are attached, a bulkhead with attaching plates at the base of the forward doorposts for the lower attachment of the wing struts, and the forgings and structure for the retractable main landing gear in the lower aft portion of the fuselage center section. Four engine mount stringers are also attached to the forward doorposts and extend forward to the firewall. A tunnel incorporated into the fuselage structure below the engine, in front of the firewall, is required for the forward retracting nose wheel.

The externally braced wings, containing the fuel tanks, are constructed of a front and rear spar with formed sheet metal ribs, doublers, and stringers. The entire structure is covered with aluminum skin. The front spars are equipped with wing-to-fuselage and wing-to-strut attach fittings. The aft spars are equipped with wing-to-fuselage attach fittings, and are partial-span spars. Conventional hinged ailerons and single-slot type flaps are attached to the trailing edge of the wings. The ailerons are constructed of a forward spar containing balance weights, formed sheet metal ribs and "V" type corrugated aluminum skin joined together at the trailing edge. The flaps are constructed basically the same as the ailerons, with the exception of balance weights and the addition of a formed sheet metal leading edge section.

The empennage (tail assembly) consists of a conventional vertical stabilizer, rudder, horizontal stabilizer, and elevator. The vertical stabilizer consists of a forward and aft spar, formed sheet metal ribs and reinforcements, a wrap-around skin panel, formed leading edge skin, and a dorsal. The rudder is constructed of a formed leading edge skin and spar with attached hinge brackets and ribs, a center spar, a wrap-around skin, and a ground adjustable trim tab at the base of the trailing edge. The top of the rudder incorporates a leading edge extension which contains a balance

**AILERON CONTROL SYSTEM**

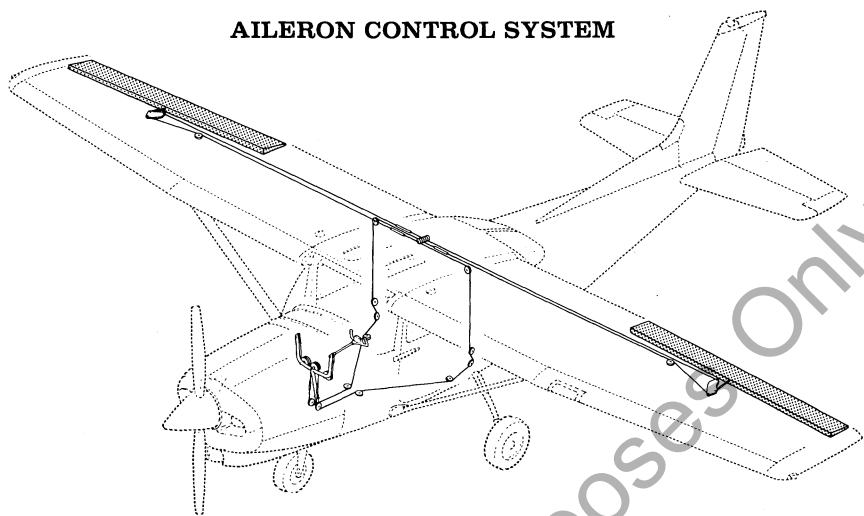

**RUDDER AND RUDDER TRIM CONTROL SYSTEMS**

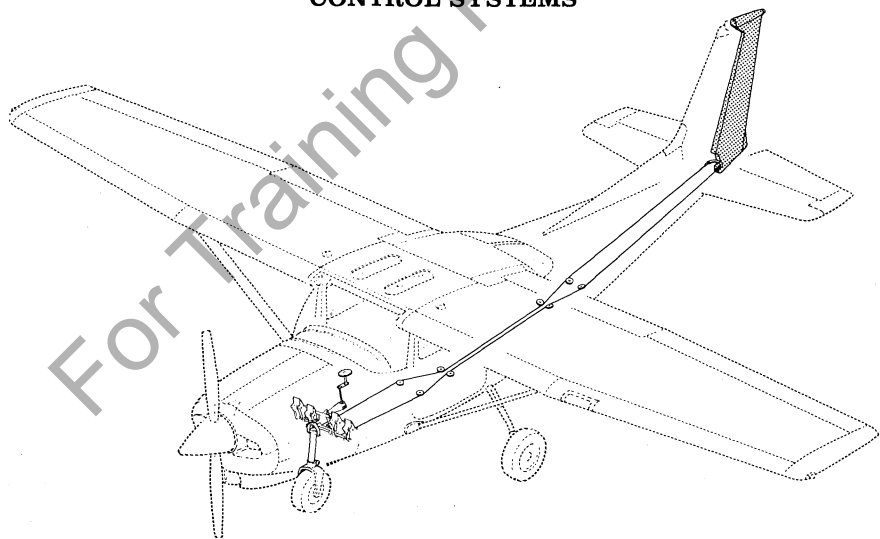
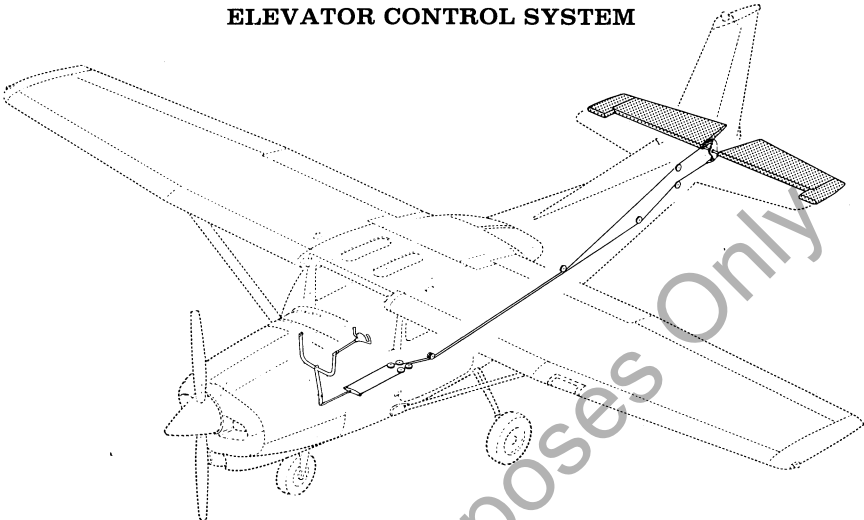

Figure 7-1. Flight Control and Trim Systems (Sheet 1 of 2)

**ELEVATOR CONTROL SYSTEM**



**ELEVATOR TRIM CONTROL SYSTEM**



Figure 7-1. Flight Control and Trim Systems (Sheet 2 of 2)

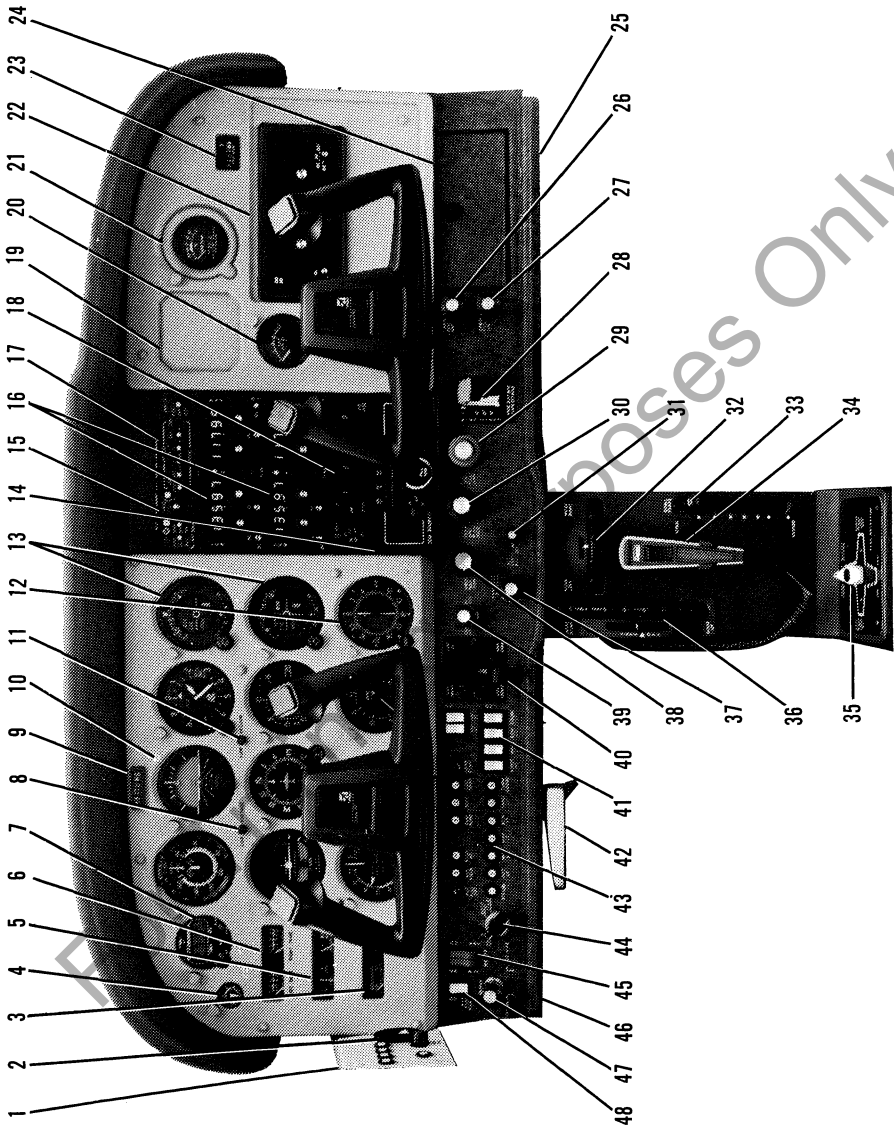

Figure 7-2. Instrument Panel (Sheet 1 of 2)

- |     |   |     |  |
|-----|---|-----|--|
| 1.  | Sidewall Circuit Breaker Panel                      | 27. | Cabin Air Control                                  |
| 2.  | Avionics Power Switch                               | 28. | Wing Flap Switch and Position Indicator            |
| 3.  | Cylinder Head Temperature and Oil Temperature Gages | 29. | Mixture Control                                    |
| 4.  | Suction Gage  | 30. | Propeller Control                                  |
| 5.  | Ammeter and Oil Pressure Gage                       | 31. | Static Pressure Alternate Source Valve             |
| 6.  | Fuel Quantity Indicators                            | 32. | Rudder Trim Control Wheel and Position Indicator   |
| 7.  | Digital Clock                                       | 33. | Cowl Flap Control Lever                            |
| 8.  | Low-Voltage Warning Light                           | 34. | Microphone   |
| 9.  | Airplane Registration Number                        | 35. | Fuel Selector Valve Handle                         |
| 10. | Flight Instrument Group                             | 36. | Elevator Trim Control Wheel and Position Indicator |
| 11. | Low-Vacuum Warning Light                            | 37. | Instrument and Radio Dial Lights Rheostats         |
| 12. | ADF Bearing Indicator                               | 38. | Throttle (With Friction Lock)                      |
| 13. | Course Deviation and Glide Slope Indicators         | 39. | Carburetor Heat Control                            |
| 14. | Autopilot Control Unit                              | 40. | Landing Gear Lever and Position Indicator Lights   |
| 15. | Marker Beacon Indicator Lights and Switches         | 41. | Electrical Switches                                |
| 16. | NAV/COM Radios                                      | 42. | Parking Brake Handle                               |
| 17. | Audio Control Panel                                 | 43. | Circuit Breakers                                   |
| 18. | Transponder   | 44. | Ignition Switch                                    |
| 19. | Additional Instrument Space                         | 45. | Master Switch                                      |
| 20. | Economy Mixture Indicator (EGT)                     | 46. | Headset Jacks (Pilot)                              |
| 21. | Carburetor Air Temperature Gage                     | 47. | Primer   |
| 22. | ADF Radio   | 48. | Auxiliary Fuel Pump Switch                         |
| 23. | Flight Hour Recorder                                |     |  |
| 24. | Map Compartment                                     |     |  |
| 25. | Headset Jacks (Front Passenger)                     |     |  |
| 26. | Cabin Heat Control                                  |     |  |

Figure 7-2. Instrument Panel (Sheet 2 of 2)

weight. The horizontal stabilizer is constructed of a forward and aft spar, ribs and stiffeners, center upper and lower skin panels, left and right upper and lower skin panels, and formed leading edge skins. The horizontal stabilizer also contains the elevator trim tab actuator. Construction of the elevator consists of formed leading edge skins, a forward spar, ribs, torque tube and bellcrank, left upper and lower "V" type corrugated skins, and right upper and lower "V" type corrugated skins incorporating a trailing edge cut-out for the trim tab. The elevator trim tab consists of a spar, rib and upper and lower "V" type corrugated skins. Both elevator tip leading edge extensions incorporate balance weights.

## FLIGHT CONTROLS

The airplane's flight control system (see figure 7-1) consists of conventional aileron, rudder, and elevator control surfaces. The control surfaces are manually operated through mechanical linkage using a control wheel for the ailerons and elevator, and rudder/brake pedals for the rudder.

Extensions are available for the rudder/brake pedals. They consist of a rudder pedal face, two spacers and two spring clips. To install an extension, place the clip on the bottom of the extension under the bottom of the rudder pedal and snap the top clip over the top of the rudder pedal. Check that the extension is firmly in place. To remove the extensions, reverse the above procedures.

## TRIM SYSTEMS

Manually-operated rudder and elevator trim is provided (see figure 7-1). Rudder trimming is accomplished through a bungee connected to the rudder control system and a trim control wheel mounted on the control pedestal. Rudder trimming is accomplished by rotating the horizontally mounted trim control wheel either left or right to the desired trim position. Rotating the trim wheel to the right will trim nose-right; conversely, rotating it to the left will trim nose-left. Elevator trimming is accomplished through the elevator trim tab by utilizing the vertically mounted trim control wheel. Forward rotation of the trim wheel will trim nose-down; conversely, aft rotation will trim nose-up.

## INSTRUMENT PANEL

The instrument panel (see figure 7-2) is designed around the basic "T" configuration. The gyros are located immediately in front of the pilot, and arranged vertically. The airspeed indicator and altimeter are located to the left and right of the gyros respectively. The remaining flight instruments

are located around the basic "T". Warning lights which indicate low voltage and low vacuum are located directly in front of the pilot between the attitude and directional indicators. The suction gage, clock, fuel quantity indicators, ammeter, oil pressure gage, oil temperature gage, and cylinder head temperature gage are located to the left of the flight instruments. Avionics equipment is stacked approximately on the centerline of the panel, with the right side of the panel containing the economy mixture indicator (EGT), flight hour recorder, and space for additional instruments and avionics equipment. A switch and control panel, at the lower edge of the instrument panel, contains most of the controls, switches, and circuit breakers necessary to operate the airplane. The left side of the panel contains the auxiliary fuel pump switch, engine primer, master switch, ignition switch, general circuit breakers, electrical switches, landing gear indicator lights, and landing gear lever. The center area contains the carburetor heat, light intensity, throttle, propeller, and mixture controls and the static pressure alternate source valve (if installed). The right side of the switch and control panel contains the wing flap switch and position indicator, cabin heat and cabin air controls, and map compartment. A pedestal, extending from the switch and control panel to the floorboard, contains the elevator and rudder trim control wheels, cowl flap control lever, and microphone bracket. The fuel selector valve handle is located at the base of the pedestal. A parking brake handle is mounted below the switch and control panel in front of the pilot. The avionics power switch and avionics circuit breakers are mounted on a small circuit breaker panel located adjacent to the pilot on the left cabin sidewall.

For details concerning the instruments, switches, circuit breakers, and controls on this panel and on the left sidewall circuit breaker panel, refer in this section to the description of the systems to which these items are related.

## GROUND CONTROL

Effective ground control while taxiing is accomplished through nose wheel steering by using the rudder pedals; left rudder pedal to steer left and right rudder pedal to steer right. When a rudder pedal is depressed, a spring-loaded steering bungee (which is connected to the nose gear and to the rudder bars) will turn the nose wheel through an arc of approximately 15° each side of center. By applying either left or right brake, the degree of turn may be increased up to 30° each side of center.

Moving the airplane by hand is most easily accomplished by attaching a tow bar to the nose gear strut. (The tow bar is stowed under the rear seat with the handle secured behind the forward seat legs. When inserted under the front of the seat and positioned in this manner, it is held secure in

maneuvering flight.) If a tow bar is not available, or pushing is required, use the wing struts as push points. Do not use the vertical or horizontal surfaces to move the airplane. If the airplane is to be towed by vehicle, never turn the nose wheel more than 30° either side of center or structural damage to the nose gear could result.

The minimum turning radius of the airplane, using differential braking and nose wheel steering during taxi, is approximately 27 feet. To obtain a minimum radius turn during ground handling, the airplane may be rotated around either main landing gear by pressing down on a tailcone bulkhead just forward of the horizontal stabilizer to raise the nose wheel off the ground.

## WING FLAP SYSTEM

The single-slot type wing flaps (see figure 7-3) are extended or retracted by positioning the wing flap switch lever on the right side of the switch and control panel to the desired flap deflection position. The switch lever is moved up or down in a slotted panel that provides mechanical stops at the 10° and 20° positions. For flap settings greater than 10°, move the switch lever to the right to clear the stop and position it as desired. A scale and pointer on the left side of the switch lever indicates flap travel in degrees. The wing flap system circuit is protected by a 15-amp push-to-reset circuit breaker, labeled FLAP, on the left side of the switch and control panel.

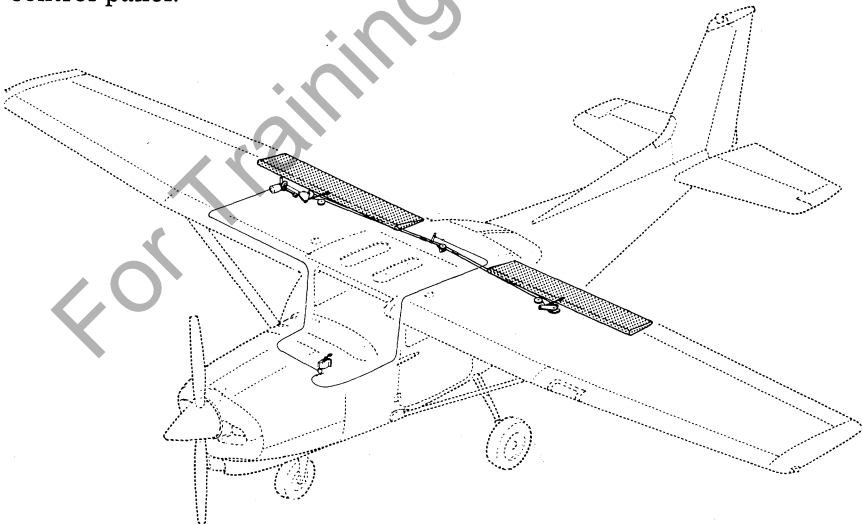

Figure 7-3. Wing Flap System



A gear warning interconnect switch is incorporated in the flap system, and sounds a warning horn when the flaps are extended beyond 20° with the landing gear retracted.

## LANDING GEAR SYSTEM

The landing gear is a retractable, tricycle type with a steerable nose wheel and two main wheels. Shock absorption is provided by the tubular spring-steel main landing gear struts and the air/oil nose gear shock strut. Each main gear wheel is equipped with a hydraulically actuated single-disc brake on the inboard side of each wheel.

The landing gear extension, retraction, and main gear down lock release operation is accomplished by hydraulic actuators powered by an electrically-driven hydraulic power pack (see figure 7-7). The power pack is located aft of the firewall between the pilot's and copilot's rudder pedals. The hydraulic system fluid level may be checked by utilizing the dipstick/filler cap located on the top left side of the power pack adjacent to the motor mounting flange. The system should be checked at 25-hour intervals. If the fluid level is at or below the ADD line on the dipstick, hydraulic fluid (MIL-H-5606) should be added to bring the level to the top of the dipstick/filler cap opening. A normal operating pressure of 1000 PSI to 1500 PSI is automatically maintained in the landing gear system, and is sufficient to provide a positive up pressure on the landing gear. The nose gear and main gear incorporate positive mechanical down locks. Also, the nose gear has mechanically-actuated wheel well doors. The doors open when the nose gear extends, and close when it retracts.

Power pack operation is started and stopped by a pressure switch, and hydraulic pressure is directed by the landing gear lever. Two position indicator lights are provided to show landing gear position and power pack operation. The landing gear system is also equipped with a nose gear safety (squat) switch, an emergency extension hand pump, and a gear-up warning system.

## LANDING GEAR LEVER

The landing gear lever is located on the switch and control panel to the right of the electrical switches. The lever has two positions, labeled GEAR UP and GEAR DOWN, which give a mechanical indication of the gear position selected. From either position, the lever must be pulled out to clear a detent before it can be repositioned; operation of the landing gear system will not begin until the lever has been repositioned. After the lever has been repositioned, it directs hydraulic pressure within the system to ac-

tuates the gear to the selected position.

## LANDING GEAR POSITION INDICATOR LIGHTS

Two position indicator lights, adjacent to the landing gear lever, indicate that the gear is down and locked (green GEAR LOCKED light on) or that one or more gear is not fully up (red GEAR UNSAFE light on). In addition, the red light is a dual function light and will illuminate anytime the gear pump motor is operating. Both of these lights are the press-to-test type, incorporating dimming shutters for night operation. If an indicator light bulb should burn out, it can be replaced in flight with the bulb from any post light or the remaining gear indicator light.

## LANDING GEAR OPERATION

To retract or extend the landing gear, pull out on the gear lever and move it to the desired position. After the lever is positioned, the power pack comes on to create pressure in the system and actuate the landing gear to the selected position. During a normal cycle, the gear extends and locks or retracts fully, limit switches actuate, and the green light comes on (extend cycle) or the red light goes off (retract cycle), indicating completion of the cycle. Whenever fluid pressure in the system drops below 1000 PSI, the pressure switch will close and start power pack operation, and the red GEAR UNSAFE light will illuminate, except when the nose gear safety (squat) switch is open.

### NOTE

It is possible to have both the red GEAR UNSAFE and the green GEAR LOCKED light on at the same time. Under normal circumstances this may occur only momentarily. However, any time both lights stay on or the red GEAR UNSAFE light does not go off, a malfunction has occurred. Refer to Section 3, Emergency Procedures, for appropriate action to be taken in this event.

The safety (squat) switch, actuated by the nose gear, electrically prevents inadvertent retraction whenever the nose gear strut is compressed by the weight of the airplane. When the nose gear is lifted off the runway during takeoff, the squat switch will close, which may cause the power pack to operate for 1 to 2 seconds (red GEAR UNSAFE light on) and return system pressure to 1500 PSI in the event pressure has dropped below 1000 PSI. A "pull-off" type circuit breaker is also provided in the system as a maintenance safety feature. With the circuit breaker pulled out, landing gear operation by the gear pump motor is prevented. After maintenance is completed, and prior to flight, the circuit breaker should be pushed back in.

## EMERGENCY HAND PUMP

A hand-operated hydraulic pump, located between the front seats, is provided for manual extension of the landing gear in the event of a hydraulic system failure. The landing gear cannot be retracted with the hand pump. To utilize the pump, extend the handle forward, and pump vertically. For complete emergency procedures, refer to Section 3.

## LANDING GEAR WARNING SYSTEM

The airplane is equipped with a landing gear warning system designed to help prevent the pilot from inadvertently making a wheels-up landing. The system consists of a throttle actuated switch which is electrically connected to a dual warning unit. The warning unit is connected to the airplane speaker.

When the throttle is retarded below approximately 12 inches of manifold pressure at low altitude (master switch on), the throttle linkage will actuate a switch which is electrically connected to the gear warning portion of a dual warning unit. If the landing gear is retracted (or not down and locked), an intermittent tone will be heard on the airplane speaker. An interconnect switch in the wing flap system also sounds the horn when the wing flaps are extended beyond 20° with the landing gear retracted.

## BAGGAGE COMPARTMENT

The baggage compartment consists of the area from the back of the rear passenger seats to the aft cabin bulkhead. A baggage shelf, above the wheel well, extends aft from the aft cabin bulkhead. Access to the baggage compartment and the shelf is gained through a lockable baggage door on the left side of the airplane, or from within the airplane cabin. A baggage net with six tie-down straps is provided for securing baggage, and is attached by tying the straps to tie-down rings provided in the airplane. For further information on baggage tie-down, refer to Section 6. When loading the airplane, children should not be placed or permitted in the baggage compartment, and any material that may be hazardous to the airplane or occupants should not be placed anywhere in the airplane. For baggage area and door dimensions, refer to Section 6.

## SEATS

The seating arrangement consists of two individually adjustable four-way or six-way seats for the pilot and front seat passenger, and a split-backed fixed seat for the rear seat passengers.

The four-way seats may be moved forward or aft, and the seat back angle adjusted to any comfortable angle. To position either seat, lift the

tubular handle under the center of the seat, slide the seat into position, release the handle, and check that the seat is locked in place. The seat back angle is controlled by a cylinder lock release button which is spring-loaded to the locked position. The release button is located on the right side, below the forward corner of the seat cushion. To adjust the angle of the seat back, push up on the release button, position the seat back to the desired angle and release the button. When the seat is not occupied, the seat back will automatically fold forward whenever the release button is pushed up.

The six-way seats may be moved forward or aft, and are infinitely adjustable for height and seat back angle. To position the seat, lift the tubular handle under the center of the seat bottom, slide the seat into position, release the handle, and check that the seat is locked in place. Raise or lower the seat by rotating the large crank under the inboard corner of either seat. The seat back is adjusted by rotating the small crank under the outboard corner of either seat. The seat bottom angle will change as the seat back angle changes, providing proper support. The seat backs will also fold full forward.

The rear passengers' seat consists of a fixed one-piece seat bottom with individually adjustable seat backs. The seat backs are adjusted by cylinder lock release buttons, recessed into skirts located below the seat frame at the outboard ends of the seat. To adjust a seat back, push up on the adjacent cylinder lock release button, which is spring-loaded to the locked position, recline the seat back to the desired position and release the button. When the seat is not occupied, the seat backs will automatically fold forward whenever the cylinder lock release button is pushed up.

Headrests are available for any of the seat configurations. To adjust the headrest, apply enough pressure to it to raise or lower it to the desired level. The headrest may be removed at any time by raising it until it disengages from the top of the seat back.

## **SEAT BELTS AND SHOULDER HARNESSSES**

All seat positions are equipped with seat belts (see figure 7-4). The pilot's and front passenger's seats are also equipped with separate shoulder harnesses; separate shoulder harnesses are available for the rear seat positions and can be readily installed to attach points furnished in the airplane. Integrated seat belt/shoulder harnesses with inertia reels can be furnished for the pilot's and front passenger's seat positions if desired.

### **SEAT BELTS**

The seat belts used with the pilot's and front passenger's seats, are attached to fittings on the floorboard. The buckle half is inboard of each seat and the link half is outboard of each seat. The belts for the rear seat are

attached to floorboard fittings and to the seat frame, with the link halves on the left and right sides of the seat bottom, and the buckles at the center of the seat bottom.

To use the seat belts for the front seats, position the seat as desired, and then lengthen the link half of the belt as needed by grasping the sides of the link and pulling against the belt. Insert and lock the belt link into the buckle. Tighten the belt to a snug fit. Seat belts for the rear seat are used in the same manner as the belts for the front seats. To release the seat belts, grasp the top of the buckle opposite the link and pull upward.

## **SHOULDER HARNESSSES**

Each front seat shoulder harness is attached to a rear doorpost above the window line and is stowed behind a stowage sheath above the cabin door. To stow the harness, fold it and place it behind the sheath. When rear seat shoulder harnesses are furnished, they are attached adjacent to the lower corners of the aft side windows. Each rear seat harness is stowed behind a stowage sheath above an aft side window.

To use a front or rear seat shoulder harness, fasten and adjust the seat belt first. Lengthen the harness as required by pulling on the connecting link on the end of the harness and the narrow release strap. Snap the connecting link firmly onto the retaining stud on the seat belt link half. Then adjust to length. A properly adjusted harness will permit the occupant to lean forward enough to sit completely erect, but prevent excessive forward movement and contact with objects during sudden deceleration. Also, the pilot will want the freedom to reach all controls easily.

Removing the shoulder harness is accomplished by pulling upward on the narrow release strap, and removing the harness connecting link from the stud on the seat belt link. In an emergency, the shoulder harness may be removed by releasing the seat belt first and allowing the harness, still attached to the link half of the seat belt, to drop to the side of the seat.

## **INTEGRATED SEAT BELT/SHOULDER HARNESSSES WITH INERTIA REELS**

Integrated seat belt/shoulder harnesses with inertia reels are available for the pilot and front seat passenger. The seat belt/shoulder harnesses extend from inertia reels located in the cabin top structure, through slots in the overhead console to attach points inboard of the two front seats. A separate seat belt half and buckle is located outboard of the seats. Inertia reels allow complete freedom of body movement. However, in the event of a sudden deceleration, they will lock automatically to protect the occupants.

STANDARD SHOULDER  
HARNESS

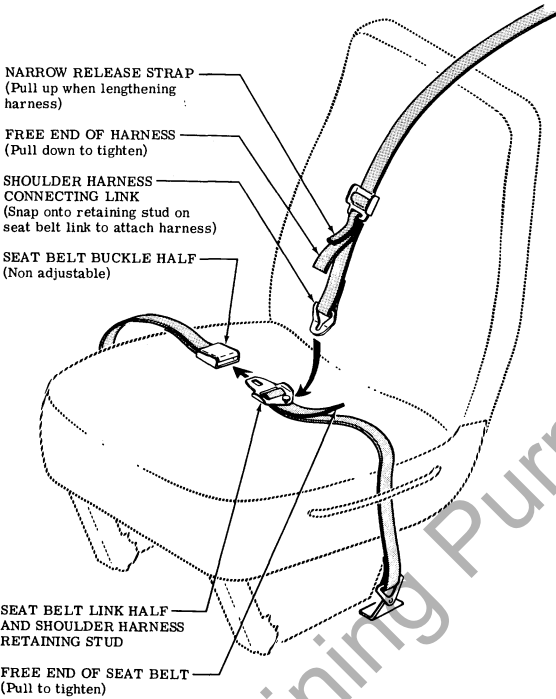

(PILOT'S SEAT SHOWN)

SEAT BELT/SHOULDER  
HARNESS WITH INERTIA  
REEL

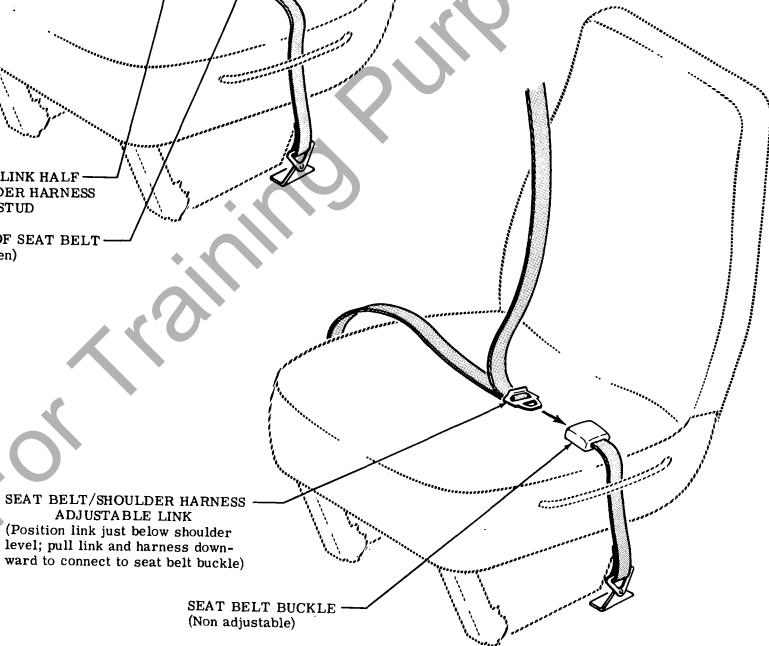

Figure 7-4. Seat Belts and Shoulder Harnesses

To use the seat belt/shoulder harness, position the adjustable metal link on the harness at about shoulder level, pull the link and harness downward, and insert the link in the seat belt buckle. Adjust belt tension across the lap by pulling upward on the shoulder harness. Removal is accomplished by releasing the seat belt buckle, which will allow the inertia reel to pull the harness inboard of the seat.

## ENTRANCE DOORS AND CABIN WINDOWS

Entry to, and exit from the airplane is accomplished through either of two entry doors, one on each side of the cabin at the front seat positions (refer to Section 6 for cabin and cabin door dimensions). The doors incorporate a recessed exterior door handle, a conventional interior door handle, a key-operated door lock (left door only), a door stop mechanism, and an openable window in the left door. An openable right door window is also available.

### NOTE

The door latch design on this model requires that the outside door handle on the pilot and front passenger doors be extended out whenever the doors are open. When closing the door, do not attempt to push the door handle in until the door is fully shut.

To open the doors from outside the airplane, utilize the recessed door handle near the aft edge of either door by grasping the forward edge of the handle and pulling outboard. To close or open the doors from inside the airplane, use the combination door handle and arm rest. The inside door handle has three positions and a placard at its base which reads OPEN, CLOSE, and LOCK. The handle is spring-loaded to the CLOSE (up) position. When the door has been pulled shut and latched, lock it by rotating the door handle forward to the LOCK position (flush with the arm rest). When the handle is rotated to the LOCK position, an over-center action will hold it in that position. Both cabin doors should be locked prior to flight, and should not be opened intentionally during flight.

### NOTE

Accidental opening of a cabin door in flight due to improper closing does not constitute a need to land the airplane. The best procedure is to set up the airplane in a trimmed condition at approximately 80 KIAS, open a window, momentarily shove the door outward slightly, and forcefully close and lock the door.

Exit from the airplane is accomplished by rotating the door handle from the LOCK position, past the CLOSE position, aft to the OPEN position and pushing the door open. To lock the airplane, lock the right cabin door

with the inside handle, close the left cabin door, and using the ignition key, lock the door.

The left cabin door is equipped with an openable window which is held in the closed position by a detent equipped latch on the lower edge of the window frame. To open the window, rotate the latch upward. The window is equipped with a spring-loaded retaining arm which will help rotate the window outward and hold it there. An openable window is also available for the right door, and functions in the same manner as the left window. If required, either window may be opened at any speed up to 164 KIAS. The cabin top windows (if installed), rear side windows, and rear window are of the fixed type and cannot be opened.

## CONTROL LOCKS

A control lock is provided to lock the aileron and elevator control surfaces to prevent damage to these systems by wind buffeting while the airplane is parked. The lock consists of a shaped steel rod and flag. The flag identifies the control lock and cautions about its removal before starting the engine. To install the control lock, align the hole in the top of the pilot's control wheel shaft with the hole in the top of the shaft collar on the instrument panel and insert the rod into the aligned holes. Installation of the lock will secure the ailerons in a neutral position and the elevators in a slightly trailing edge down position. Proper installation of the lock will place the flag over the ignition switch. In areas where high or gusty winds occur, a control surface lock should be installed over the vertical stabilizer and rudder. The control lock and any other type of locking device should be removed prior to starting the engine.

## ENGINE

The airplane is powered by a horizontally-opposed, four-cylinder, overhead-valve, air-cooled, carbureted engine with a wet sump lubrication system. The engine is a Lycoming Model O-360-F1A6 and is rated at 180 horsepower at 2700 RPM. Major accessories include a starter, belt-driven alternator, and propeller governor on the front of the engine and dual magnetos, fuel pump, vacuum pump, and full-flow oil filter on the rear of the engine.

## ENGINE CONTROLS

Engine manifold pressure is controlled by a throttle located on the center area of the switch and control panel. The throttle operates in a conventional manner; in the full forward position, the throttle is open, and in the full aft position, it is closed. A friction lock, which is a round knurled



disk, is located at the base of the throttle and is operated by rotating the lock clockwise to increase friction or counterclockwise to decrease it.

The mixture control, mounted near the propeller control, is a red knob with raised points around the circumference and is equipped with a lock button in the end of the knob. The rich position is full forward, and full aft is the idle cut-off position. For small adjustments, the control may be moved forward by rotating the knob clockwise, and aft by rotating the knob counterclockwise. For rapid or large adjustments, the knob may be moved forward or aft by depressing the lock button in the end of the control, and then positioning the control as desired.

## ENGINE INSTRUMENTS

Engine operation is monitored by the following instruments: oil pressure gage, oil temperature gage, cylinder head temperature gage, tachometer, manifold pressure gage and fuel pressure gage. An economy mixture (EGT) indicator and carburetor air temperature gage are also available.

The oil pressure gage, located on the left side of the instrument panel, is operated by oil pressure. A direct pressure oil line from the engine delivers oil at engine operating pressure to the oil pressure gage. Gage markings indicate that minimum idling pressure is \*25 PSI (red line), the normal operating range is \*60 to 90 PSI (green arc), and maximum pressure is 115 PSI (red line).

Oil temperature is indicated by a gage below the oil pressure gage. The gage is operated by an electrical resistance type temperature sensor which receives power from the airplane electrical system. Gage markings indicate the normal operating range (green arc) which is 100°F (38°C) to 245°F (118°C), and the maximum (red line) which is 245°F (118°C).

The cylinder head temperature gage, adjacent to the oil temperature gage, is operated by an electrical-resistance type temperature sensor on the engine which receives power from the airplane electrical system. Gage markings indicate the normal operating range (green arc) which is 200°F (93°C) to 500°F (260°C) and the maximum (red line) which is 500°F (260°C).

The engine-driven mechanical tachometer is located on the lower right side of the pilot's control column. The instrument is calibrated in increments of 100 RPM and indicates both engine and propeller speed. An hour meter below the center of the tachometer dial records elapsed engine time in hours and tenths. Instrument markings include a normal operating range (multiple width green arc) of 2100 to 2700 RPM, and a maximum (red line) of 2700 RPM.

\* 20 psi (red line) and 50 to 90 psi (green arc) on airplanes modified by Service Kit SK172-85.

26 May 1982

Revision 2 - 1 December 1983

7-19

The manifold pressure gage is the left half of a dual-indicating instrument located on the lower left side of the pilot's control column. The gage is direct reading and indicates induction air manifold pressure in inches of mercury. It has a normal operating range (green arc) of 15 to 25 inches of mercury.

The fuel pressure gage is the right half of this dual-indicating instrument located on the lower left side of the pilot's control column. The gage indicates fuel pressure to the carburetor. Gage markings indicate that minimum pressure is 0.5 PSI (red line), normal operating range is 0.5 to 8 PSI (green arc), and maximum pressure is 8 PSI (red line).

An economy mixture (EGT) indicator is available for the airplane and is located on the right side of the instrument panel. A thermocouple probe in the right exhaust stack assembly measures exhaust gas temperature and transmits it to the indicator. The indicator serves as a visual aid to the pilot in adjusting the mixture during climb or cruise as described in Section 4. Exhaust gas temperature varies with fuel-to-air ratio, power, and RPM. However, the difference between the peak EGT and the EGT at the desired mixture setting is essentially constant and this provides a useful leaning aid. The indicator is equipped with a manually positioned reference pointer which is especially useful for leaning during climb.

A carburetor air temperature gage is available for the airplane. Details of this gage are presented in Section 9, Supplements.

## **NEW ENGINE BREAK-IN AND OPERATION**

The engine underwent a run-in at the factory and is ready for the full range of use. It is, however, suggested that cruising be accomplished at 75% power as much as practicable until a total of 50 hours has accumulated or oil consumption has stabilized. This will ensure proper seating of the rings.

## **ENGINE LUBRICATION SYSTEM**

The engine utilizes a full pressure, wet sump-type lubrication system with aviation grade oil used as the lubricant. Engine oil is also used for propeller and propeller governor operation. The capacity of the engine sump (located on the bottom of the engine) is 8 quarts (one additional quart is required for the full flow oil filter). Oil is drawn from the sump through an oil suction strainer screen into the engine-driven oil pump. From the pump, oil is routed to a bypass valve. If the oil is cold, the bypass valve allows the oil to bypass the oil cooler and go directly from the pump to the full flow oil filter. If the oil is hot, the bypass valve routes the oil out of the accessory housing and into a flexible hose leading to the oil cooler on the upper right side of the engine. Pressure oil from the cooler returns to the accessory housing where it passes through the oil filter. The filtered

oil then enters a pressure relief valve which regulates engine oil pressure by allowing excessive oil to return to the sump while the balance of the oil is circulated to various engine parts for lubrication. Residual oil is returned to the sump by gravity flow.

An oil filler cap/oil dipstick is located at the rear of the engine on the right side. The filler cap/dipstick is accessible through an access door in the engine cowling. The engine should not be operated on less than five quarts of oil. To minimize loss of oil through the breather, fill to seven quarts for normal flights of less than three hours. For extended flight, fill to eight quarts (dipstick indication only). For engine oil grade and specifications, refer to Section 8 of this handbook.

An oil quick-drain valve is installed on the bottom of the oil sump, to provide a quick, clean method of draining the engine oil. To drain the oil, slip a hose over the end of the valve and push upward on the end of the valve until it snaps into the open position. Spring clips will hold the valve open. After draining, use a suitable tool to snap the valve into the extended (closed) position and remove the drain hose.

## IGNITION-STARTER SYSTEM

Engine ignition is provided by two engine-driven magnetos, and two spark plugs in each cylinder. The right magneto fires the lower right and upper left spark plugs, and the left magneto fires the lower left and upper right spark plugs. Normal operation is conducted with both magnetos due to the more complete burning of the fuel-air mixture with dual ignition.

Ignition and starter operation is controlled by a rotary type switch located on the left switch and control panel. The switch is labeled clockwise, OFF, R, L, BOTH, and START. The engine should be operated on both magnetos (BOTH position) except for magneto checks. The R and L positions are for checking purposes and emergency use only. When the switch is rotated to the spring-loaded START position (with the master switch in the ON position), the starter contactor is energized and the starter will crank the engine. When the switch is released, it will automatically return to the BOTH position.

## AIR INDUCTION SYSTEM

Ram air for the engine induction system is received through the left opening in the nose cap. An induction system air scoop is located in the aft vertical baffle just behind the engine on the left side. This scoop is covered by an air filter which removes dust and other foreign matter from the

induction air. After passing through the filter, the induction air enters an airbox which is mounted on the carburetor inlet. From the airbox, the air enters the carburetor and is ducted to the engine cylinders through intake manifold tubes. In the event carburetor ice is encountered or the intake filter becomes blocked, alternate heated air can be obtained from a shroud around number four cylinder exhaust riser. This heated air is ducted to the airbox and passes through a valve controlled by the carburetor heat control on the instrument panel. Heated air from the shroud is obtained from unfiltered air inside the cowling. Use of full carburetor heat at full throttle will result in a loss of approximately one inch of manifold pressure.

## **EXHAUST SYSTEM**

Exhaust gas from each cylinder passes through riser assemblies to a muffler and tailpipe. The muffler is constructed with a shroud around the outside which forms a heating chamber for cabin heater air.

## **CARBURETOR AND PRIMING SYSTEM**

The engine is equipped with a horizontally-mounted, side-draft, float-type, fixed jet carburetor mounted below the engine adjacent to the firewall. The carburetor is equipped with an enclosed accelerator pump, an idle cut-off mechanism, and a manual mixture control. Fuel is delivered from the fuel system to the carburetor by gravity flow, the engine-driven fuel pump, and/or auxiliary fuel pump. In the carburetor, fuel is atomized, proportionally mixed with intake air, and delivered to the cylinders through intake manifold tubes. The proportion of atomized fuel to air may be controlled, within limits, by the mixture control located on the center area of the switch and control panel.

For easy starting in cold weather, the engine is equipped with a 3-cylinder manual primer. The primer is actually a small pump which draws fuel from the fuel strainer when the plunger knob is pulled out, and injects it into the engine intake ports when the knob is pushed back in. The plunger knob is equipped with a lock and, after being pushed full in, must be rotated either left or right until the knob cannot be pulled out.

## **COOLING SYSTEM**

Ram air for engine cooling enters through two intake openings in the front of the engine cowling. The cooling air is directed around the cylinders and other areas of the engine by baffling, and is then exhausted through cowl flaps on the lower aft edge of the cowling. The cowl flaps are mechanically operated from the cabin by means of a cowl flap lever on the right side of the control pedestal. The pedestal is labeled OPEN, COWL FLAPS, CLOSED. Before starting the engine, and throughout takeoff and

high power climb operation, the cowl flap lever should be placed in the OPEN position for maximum cooling. This is accomplished by moving the lever to the right to clear a detent, then moving the lever up to the OPEN position. Anytime the lever is repositioned, it must first be moved to the right. While in cruise flight, cowl flaps should be adjusted to keep the cylinder head temperature at approximately two-thirds of the normal operating range (green arc). During extended let-downs, the cowl flaps should be completely closed by pushing the cowl flap lever down to the CLOSED position.

A winterization kit is available for the airplane. Details of this kit are presented in Section 9, Supplements.

## PROPELLER

The airplane has an all-metal, two-bladed, constant-speed, governor-regulated propeller. A setting introduced into the governor with the propeller control establishes the propeller speed, and thus the engine speed to be maintained. The governor then controls flow of engine oil, boosted to high pressure by the governing pump, to or from a piston in the propeller hub. Oil pressure acting on the piston twists the blades toward high pitch (low RPM). When oil pressure to the piston in the propeller hub is relieved, centrifugal force, assisted by an internal spring, twists the blades toward low pitch (high RPM).

A control knob on the center area of the switch and control panel is used to set the propeller and control engine RPM as desired for various flight conditions. The knob is labeled PROP RPM, PUSH INCR. When the control knob is pushed in, blade pitch will decrease, giving a higher RPM. When the control knob is pulled out, the blade pitch increases, thereby decreasing RPM. The propeller control knob is equipped with a vernier feature which allows slow or fine RPM adjustments by rotating the knob clockwise to increase RPM, and counterclockwise to decrease it. To make rapid or large adjustments, depress the button on the end of the control knob and reposition the control as desired.

## FUEL SYSTEM

The airplane fuel system (see figure 7-5) consists of two vented integral fuel tanks (one in each wing), a four-position selector valve, fuel strainer, manual primer, engine-driven fuel pump, electric auxiliary fuel pump and carburetor. Refer to figure 7-6 for fuel quantity data for the system.

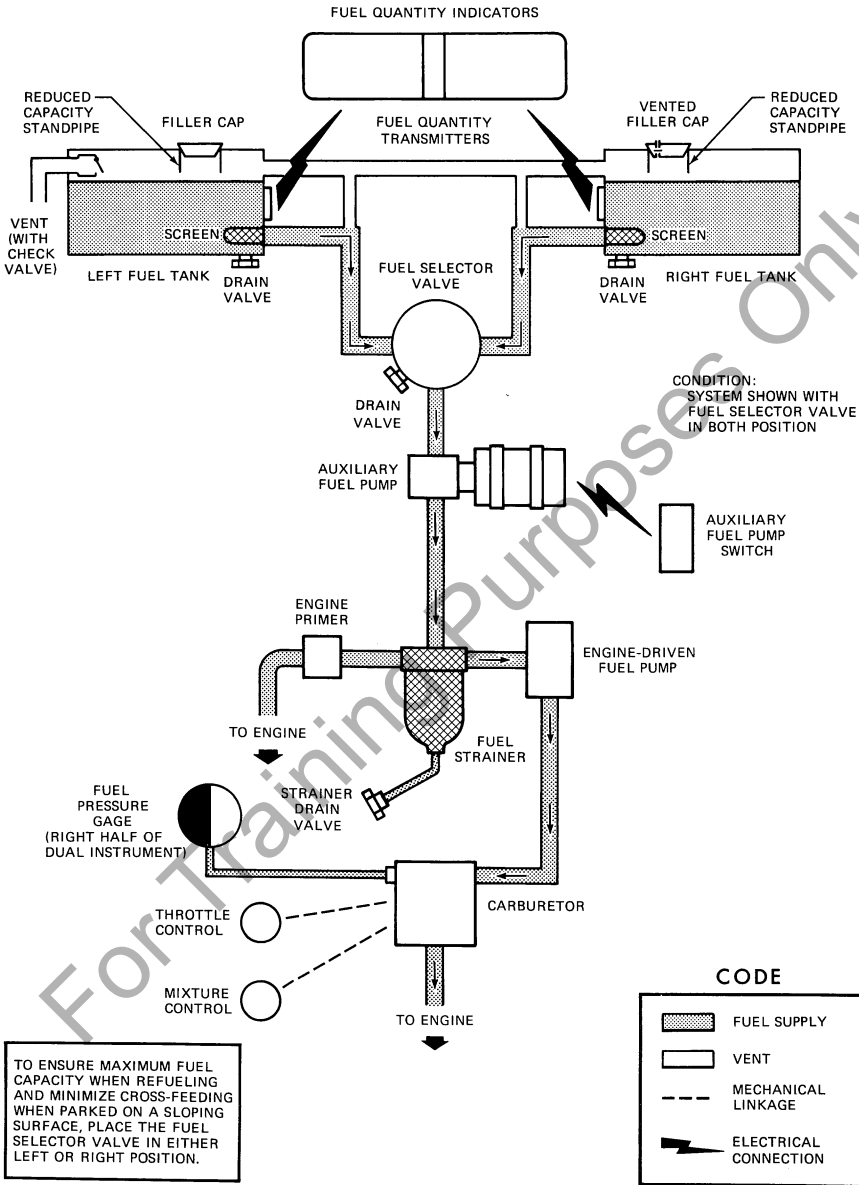

Figure 7-5. Fuel System

Fuel flows by gravity from the two integral wing tanks to a four-position selector valve, labeled BOTH, RIGHT, LEFT, and OFF. With the selector valve in either the BOTH, RIGHT, or LEFT position, fuel flows through a bypass in the auxiliary fuel pump (when it is not in operation) and a strainer to the engine-driven fuel pump, and from the pump to the carburetor. From the carburetor, mixed fuel and air flows to the cylinders through intake manifold tubes. The manual primer draws its fuel from the fuel strainer and injects it into the engine intake ports.

The airplane may be serviced to a reduced fuel capacity to permit heavier cabin loadings by filling each fuel tank to the bottom edge of the fuel filler collar, thus giving a reduced fuel load of 24.0 gallons in each tank (22 gallons usable in all flight conditions).

Fuel system venting is essential to system operation. Blockage of the system will result in decreasing fuel flow and eventual engine stoppage. Venting is accomplished by an interconnecting line from the right fuel tank to the left tank. The left fuel tank is vented overboard through a vent line, equipped with a check valve, which protrudes from the bottom surface of the left wing near the wing strut. The right fuel tank filler cap is also vented.

Fuel quantity is measured by two float-type fuel quantity transmitters (one in each tank) and indicated by two electrically-operated fuel quantity indicators on the left side of the instrument panel. The fuel quantity indicators are calibrated in gallons (lower scale) and pounds (upper scale). An empty tank is indicated by a red line and the letter E. When an indicator shows an empty tank, approximately 2 gallons remain in a tank as unusable fuel. The indicators cannot be relied upon for accurate readings during skids, slips, or unusual attitudes. If both indicator pointers should rapidly move to a zero reading, check the cylinder head temperature gage for operation. If these gages are not indicating, an electrical malfunction has occurred.

The auxiliary fuel pump switch is located on the left side of the switch and control panel and is a rocker-type switch. It is labeled AUX FUEL PUMP. When the pump is operating, it will maintain fuel pressure to the carburetor. It should be used whenever the indicated fuel pressure falls below 0.5 PSI, but is not required when gravity flow and/or the engine-driven fuel pump can maintain indicated pressures above 0.5 PSI.

The fuel selector valve should be in the BOTH position for takeoff, climb, descent, landing, and maneuvers that involve prolonged slips or skids. Operation from either LEFT or RIGHT tank is reserved for level cruising flight only.

FUEL QUANTITY DATA (U.S. GALLONS)				
FUEL TANKS	FUEL LEVEL (QUANTITY EACH TANK)	TOTAL FUEL	TOTAL UNUSABLE	TOTAL USABLE ALL FLIGHT CONDITIONS
STANDARD	FULL (33)	66	4	62
	REDUCED (24)	48	4	44

Figure 7-6. Fuel Quantity Data

NOTE

Unusable fuel is at a minimum due to the design of the fuel system. However, with 1/4 tank or less, prolonged uncoordinated flight such as slips or skids can uncover the fuel tank outlets, causing fuel starvation and engine stoppage. Therefore, with low fuel reserves, do not allow the airplane to remain in uncoordinated flight for periods in excess of 30 seconds.

NOTE

When the fuel selector valve handle is in the BOTH position in cruising flight, unequal fuel flow from each tank may occur if the wings are not maintained exactly level. Resulting wing heaviness can be alleviated gradually by turning the selector valve handle to the tank in the "heavy" wing.

NOTE

It is not practical to measure the time required to consume all of the fuel in one tank, and, after switching to the opposite tank, expect an equal duration from the remaining fuel. The airspace in both fuel tanks is interconnected by a vent line and, therefore, some sloshing of fuel between tanks can be expected when the tanks are nearly full and the wings are not level.

If a fuel tank quantity is completely exhausted in flight, it is recommended that the fuel selector valve be switched back to the BOTH position for the remainder of the flight. This will allow some fuel from the fuller tank to transfer back through the selector valve to the empty tank while in coordinated flight which in turn will prevent fuel starvation when operating in prolonged slips or skids.



The fuel system is equipped with drain valves to provide a means for the examination of fuel in the system for contamination and grade. The system should be examined before the first flight of every day and after each refueling, by using the sampler cup provided to drain fuel from the wing tank sumps and selector valve, and the fuel strainer drain valve on the lower left side of the engine cowling. If takeoff weight limitations for the next flight permit, the fuel tanks should be filled after each flight to prevent condensation.

## HYDRAULIC SYSTEM

Hydraulic power (see figure 7-7) is supplied by an electrically-driven hydraulic power pack located behind the firewall between the pilot's and copilot's rudder pedals. The power pack's only function is to supply hydraulic power for operation of the retractable landing gear. This is accomplished by applying hydraulic pressure to actuator cylinders which extend or retract the gear. The hydraulic system normally operates at 1000 PSI to 1500 PSI, and is protected by relief valves which prevent high pressure damage to the pump and other components in the system. The electrical portion of the power pack is protected by a 35-amp "pull-off" type circuit breaker switch, labeled GEAR PUMP, on the left switch and control panel.

The hydraulic power pack is turned on by a pressure switch on the power pack when the landing gear lever is placed in either the GEAR UP or GEAR DOWN position. When the lever is placed in the GEAR UP or GEAR DOWN position, it mechanically rotates a selector valve which applies hydraulic pressure in the direction selected. As soon as the landing gear reaches the selected position, a series of electrical switches will illuminate the green GEAR LOCKED light and turn off the red GEAR UNSAFE light to show gear position and completion of the cycle.

### NOTE

In the event the hydraulic pump continues to run (longer than one minute) after completion of a cycle as evidenced by audible sound from the gear pump motor and the red GEAR UNSAFE light staying on, it is recommended that the circuit breaker labeled GEAR PUMP be pulled out to prevent possible damage due to overheating.

The hydraulic system includes an emergency hand pump to permit manual extension of the landing gear in the event of hydraulic power pack failure. The hand pump is located on the cabin floor between the front seats.

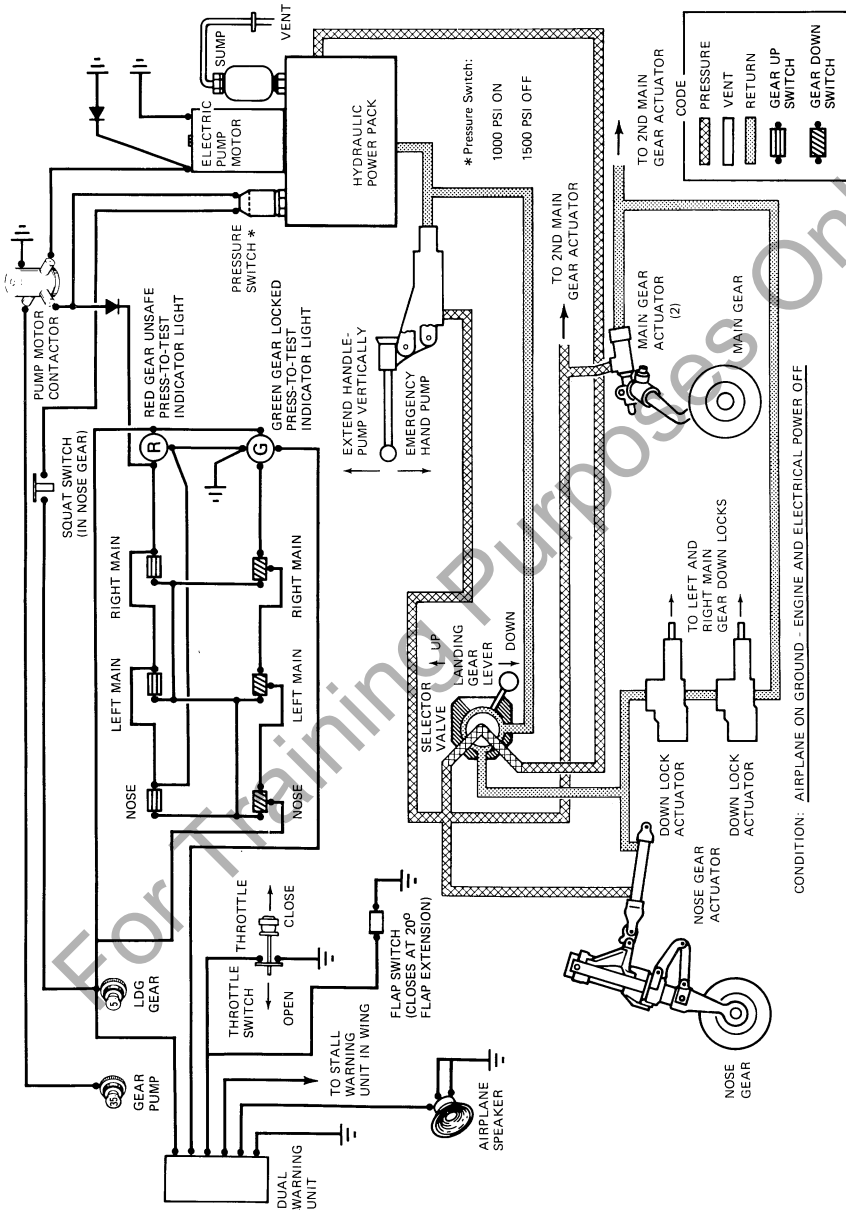

Figure 7-7. Hydraulic System

During normal operations, the landing gear should require from 5 to 7 seconds to fully extend or retract. For malfunctions of the hydraulic and landing gear systems, refer to Section 3 of this handbook.

## BRAKE SYSTEM

The airplane has a single-disc, hydraulically-actuated brake on each main landing gear wheel. Each brake is connected, by a hydraulic line, to a master cylinder attached to each of the pilot's rudder pedals. The brakes are operated by applying pressure to the top of either the left (pilot's) or right (copilot's) set of rudder pedals, which are interconnected. When the airplane is parked, both main wheel brakes may be set by utilizing the parking brake which is operated by a handle below the left side of the switch and control panel. To apply the parking brake, set the brakes with the rudder pedals, pull the handle aft, and rotate it 90° down.

For maximum brake life, keep the brake system properly maintained, and minimize brake usage during taxi operations and landings.

Some of the symptoms of impending brake failure are: gradual decrease in braking action after brake application, noisy or dragging brakes, soft or spongy pedals, and excessive travel and weak braking action. If any of these symptoms appear, the brake system is in need of immediate attention. If, during taxi or landing roll, braking action decreases, let up on the pedals and then re-apply the brakes with heavy pressure. If the brakes become spongy or pedal travel increases, pumping the pedals should build braking pressure. If one brake becomes weak or fails, use the other brake sparingly while using opposite rudder, as required, to offset the good brake.

## ELECTRICAL SYSTEM

The airplane is equipped with a 28-volt, direct-current electrical system (see figure 7-8). The system uses a battery, located aft of the rear cabin wall, as the source of electrical energy and a belt-driven 60-amp alternator to maintain the battery's state of charge. Power is supplied to most general electrical and all avionics circuits through the primary bus bar and the avionics bus bar, which are interconnected by an avionics power switch. The primary bus bar is on anytime the master switch is turned on, and is not affected by starter or external power usage. Both bus bars are on anytime the master and avionics power switches are on.

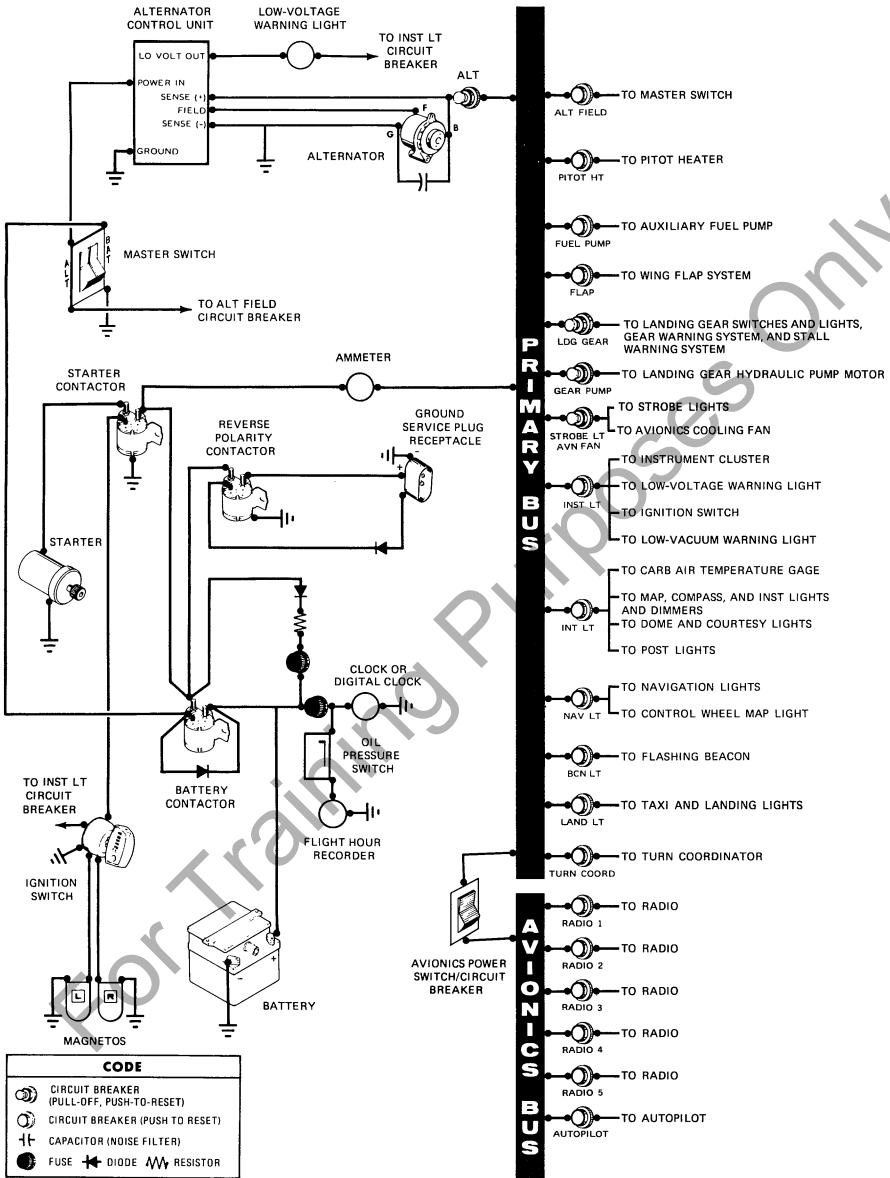

Figure 7-8. Electrical System

### CAUTION

Prior to turning the master switch on or off, starting the engine, or applying an external power source, the avionics power switch, labeled AVN PWR, should be turned off to prevent any harmful transient voltage from damaging the avionics equipment.

### MASTER SWITCH

The master switch is a split-rocker type switch labeled MASTER, and is ON in the up position and off in the down position. The right half of the switch, labeled BAT, controls all electrical power to the airplane. The left half, labeled ALT, controls the alternator.

Normally, both sides of the master switch should be used simultaneously; however, the BAT side of the switch could be turned ON separately to check equipment while on the ground. To check or use avionics equipment or radios while on the ground, the avionics power switch must be turned ON. The ALT side of the switch, when placed in the off position, removes the alternator from the electrical system. With this switch in the off position, the entire electrical load is placed on the battery. Continued operation with the alternator switch in the off position will reduce battery power low enough to open the battery contactor, remove power from the alternator field, and prevent alternator restart.

### AVIONICS POWER SWITCH

Electrical power from the airplane primary bus to the avionics bus (see figure 7-8) is controlled by a single rocker switch/circuit breaker labeled AVN PWR. The switch is located on the left sidewall circuit breaker panel and is ON in the up position and OFF in the down position. With the switch in the OFF position, no electrical power will be applied to the avionics equipment, regardless of the position of the master switch or the individual equipment switches. The avionics power switch also functions as a circuit breaker. If an electrical malfunction should occur and cause the circuit breaker to open, electrical power to the avionics equipment (including the avionics cooling fan) will be interrupted and the switch will automatically move to the OFF position. If this occurs, allow the circuit breaker to cool approximately two minutes before placing the switch in the ON position again. If the circuit breaker opens again, do not reset it. The avionics power switch should be placed in the OFF position prior to turning the master switch ON or off, starting the engine, or applying an external power source, and may be utilized in place of the individual avionics equipment switches.

## AMMETER

The ammeter, located beneath the fuel gages, indicates the amount of current, in amperes, from the alternator to the battery or from the battery to the airplane electrical system. When the engine is operating and the master switch is turned on, the ammeter indicates the charging rate applied to the battery. In the event the alternator is not functioning or the electrical load exceeds the output of the alternator, the ammeter indicates the battery discharge rate.

## ALTERNATOR CONTROL UNIT AND LOW-VOLTAGE WARNING LIGHT

The airplane is equipped with a combination alternator regulator high-voltage control unit mounted on the engine side of the firewall and a red warning light, labeled **LOW VOLTAGE**, on the left side of the instrument panel above the pilot's control column.

In the event an over-voltage condition occurs, the alternator control unit automatically removes alternator field current which shuts down the alternator. The battery will then supply system current as shown by a discharge rate on the ammeter. Under these conditions, depending on electrical system load, the low-voltage warning light will illuminate when system voltage drops below normal. The alternator control unit may be reset by turning the master switch off and back on again. If the warning light does not illuminate, normal alternator charging has resumed; however, if the light does illuminate again, a malfunction has occurred, and the flight should be terminated as soon as practicable.

### NOTE

Illumination of the low-voltage light and ammeter discharge indications may occur during low RPM conditions with an electrical load on the system, such as during a low RPM taxi. Under these conditions, the light will go out at higher RPM. The master switch need not be recycled since an over-voltage condition has not occurred to de-activate the alternator system.

The warning light may be tested by turning on the landing lights and momentarily turning off the ALT portion of the master switch while leaving the BAT portion turned on.

## CIRCUIT BREAKERS AND FUSES

Most of the electrical circuits in the airplane are protected by "push-to-reset" type circuit breakers mounted on the lower left side of the switch

and control panel. However, circuit breakers protecting the alternator output, the landing gear system hydraulic pump motor and position indicator lights circuits, and the strobe light/avionics cooling fan circuits are the "pull-off" type. In addition to the individual circuit breakers, a single-rocker switch/circuit breaker, labeled AVN PWR on the avionics panel, located on the left cabin sidewall between the forward doorpost and the switch and control panel, also protects the avionics systems. The control wheel map light (if installed) is protected by the NAV LIGHTS circuit breaker and a fuse behind the instrument panel. Electrical circuits which are not protected by circuit breakers are the battery contactor closing (external power) circuit, clock circuit, and flight hour recorder circuit. These circuits are protected by fuses mounted adjacent to the battery.

Spare fuses are required to be carried in the airplane at all times. To assist the pilot in meeting this requirement, a special spare fuse holder is located inside the cover of the Pilot's Operating Handbook. This holder contains an assortment of spare fuses to be used in the event an installed fuse requires replacement. If one of the fuses from the holder is used, a replacement spare should be obtained for the fuse holder.

## GROUND SERVICE PLUG RECEPTACLE

A ground service plug receptacle may be installed to permit the use of an external power source for cold weather starting and during lengthy maintenance work on the electrical and electronic equipment. Details of the ground service plug receptacle are presented in Section 9, Supplements.

## LIGHTING SYSTEMS

### EXTERIOR LIGHTING

Conventional navigation lights are located on the wing tips and top of the rudder. Dual landing/taxi lights are located in the left wing leading edge. Additional lighting is available and includes a flashing beacon mounted on top of the vertical fin, a strobe light on each wing tip, and a courtesy light recessed into the lower surface of each wing slightly outboard of the cabin doors. Details of the strobe light system are presented in Section 9, Supplements. The courtesy lights are operated by the DOME LIGHTS switch located on the overhead console; push the switch to the right to turn the lights on. The remaining exterior lights are operated by rocker switches located on the left switch and control panel; push the rocker up to the ON position.

The flashing beacon should not be used when flying through clouds or overcast; the flashing light reflected from water droplets or particles in the atmosphere, particularly at night, can produce vertigo and loss of orientation.

## INTERIOR LIGHTING

Instrument panel and switch and control panel lighting is provided by flood lighting, integral lighting, and post lighting (if installed). Lighting intensity is controlled by a dual dimming rheostat equipped with an outer knob labeled PANEL LT, and an inner knob labeled RADIO LT, located below the throttle. A slide-type switch (if installed) on the overhead console, labeled PANEL LIGHTS, is used to select flood lighting in the FLOOD position, post lighting in the POST position, or a combination of post and flood lighting in the BOTH position.

Instrument panel and switch and control panel flood lighting consists of a single red flood light in the forward edge of the overhead console. To use flood lighting, move the slide switch in the overhead console, labeled PANEL LIGHTS, to the FLOOD position and rotate the outer knob on the light dimming rheostat, labeled PANEL LT, clockwise to the desired light intensity.

Post lights (if installed) are mounted at the edge of each instrument and provide direct lighting. To use post lighting, move the slide switch in the overhead console, labeled PANEL LIGHTS, to the POST position and rotate the outer knob on the light dimming rheostat, labeled PANEL LT, clockwise to obtain the desired light intensity. When the PANEL LIGHTS switch is placed in the BOTH position, the flood lights and post lights will operate simultaneously.

The engine instrument cluster, radio equipment, digital clock and magnetic compass have integral lighting and operate independently of post or flood lighting. The intensity of instrument cluster, radio, and digital clock lighting is controlled by the inner knob on the light dimming rheostat labeled RADIO LT; compass lighting is controlled by the outer knob labeled PANEL LT. Rotate the knobs clockwise to obtain the desired light intensity. However, for daylight operation, the engine instrument, digital clock and compass lights may be turned off while still maintaining maximum light intensity for the digital readouts in the radio equipment. This is accomplished by rotating the knobs full counterclockwise. The flood lights/post lights are also turned off for daylight operation by rotating the PANEL LT knob full counterclockwise.

A cabin dome light, in the aft part of the overhead console, is operated by a switch near the light. To turn the light on, move the switch to the right.



A control wheel map light is available and is mounted on the bottom of the pilot's control wheel. The light illuminates the lower portion of the cabin just forward of the pilot and is helpful when checking maps and other flight data during night operations. To operate the light, first turn on the NAV LT switch; then adjust the map light's intensity with the knurled disk type rheostat control located at the bottom of the control wheel.

A doorpost map light is located on the left forward doorpost. It contains both red and white bulbs and may be positioned to illuminate any area desired by the pilot. The light is controlled by a switch, below the light, which is labeled RED, OFF, and WHITE. Placing the switch in the top position will provide a red light. In the bottom position, standard white lighting is provided. In the center position, the map light is turned off. Red light intensity is controlled by the outer knob on the light dimming rheostat labeled PANEL LT.

The most probable cause of a light failure is a burned out bulb; however, in the event any of the lighting systems fail to illuminate when turned on, check the appropriate circuit breaker. If the circuit breaker has opened (white button popped out), and there is no obvious indication of a short circuit (smoke or odor), turn off the light switch of the affected lights, reset the breaker, and turn the switch on again. If the breaker opens again, do not reset it.

## **CABIN HEATING, VENTILATING AND DEFROSTING SYSTEM**

Heated air from a muffler shroud and heater valve and ventilating air from an external ventilating air door are supplied to a manifold just forward of the pilot's and copilot's feet (see figure 7-9). The temperature and volume of airflow to the manifold and then to the cabin is regulated by manipulation of the push-pull CABIN HEAT and CABIN AIR controls. Both controls permit intermediate settings.

Cabin heat and ventilating air from the manifold to the cabin is supplied by two ducts, one extending down each side of the cabin to an outlet at the front door post at floor level. Windshield defrost air is also supplied by dual ducts leading from the cabin manifold to outlets on top of the glare shield. Two knobs on each outlet control sliding valves which permit regulation of defroster airflow.

For cabin ventilation, pull the CABIN AIR knob out, with the CABIN HEAT knob pushed full in. To raise the air temperature, pull the CABIN HEAT knob out until the desired temperature is attained. Additional heat is available by pulling the knob out farther; maximum heat is available

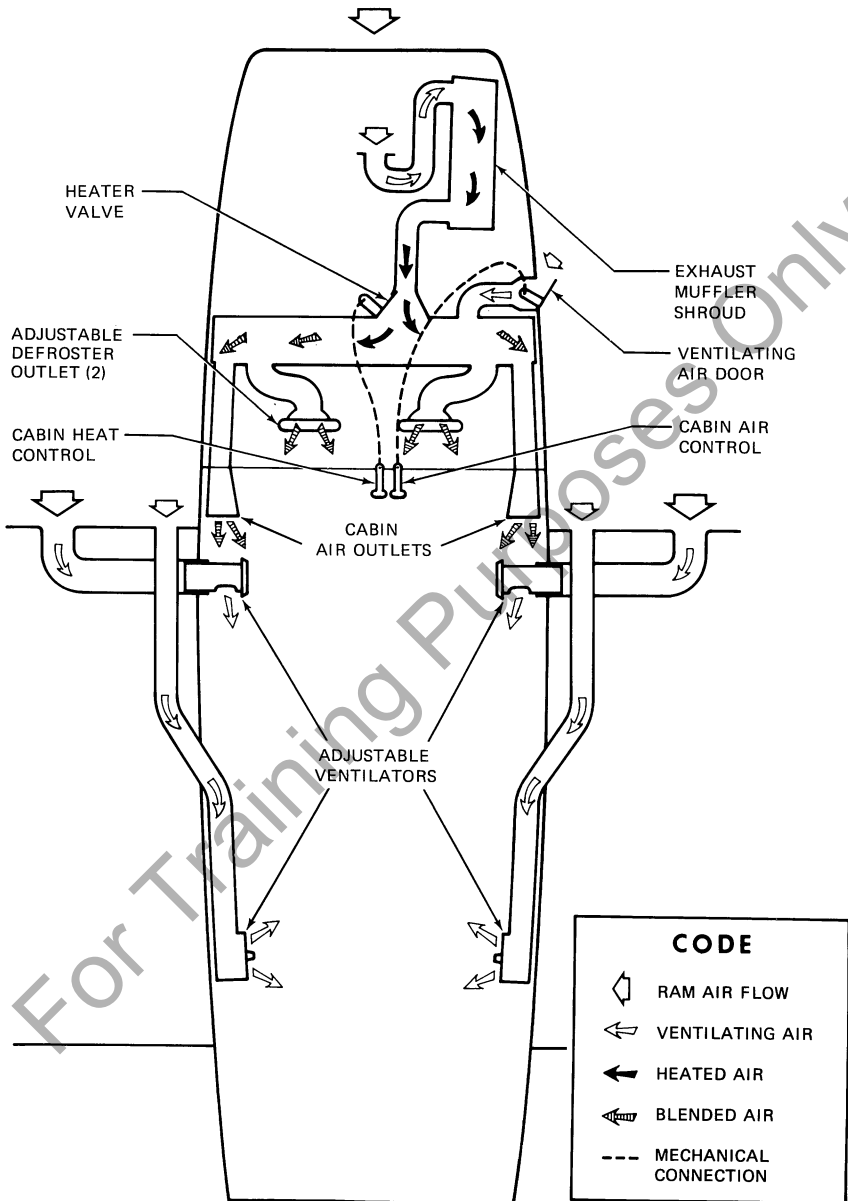

Figure 7-9. Cabin Heating, Ventilating, and Defrosting System

with the CABIN HEAT knob pulled out and the CABIN AIR knob pushed full in.

#### NOTE

For improved partial heating on mild days, pull out the CABIN AIR knob slightly when the CABIN HEAT knob is out. This action increases the airflow through the system, increasing efficiency, and blends cool outside air with the exhaust manifold heated air, thus eliminating the possibility of overheating the system ducting.

Separate adjustable ventilators supply additional ventilation air to the cabin. One near each upper corner of the windshield supplies air for the pilot and copilot, and two ventilators are available for the rear cabin area to supply air to the rear seat passengers. Each rear ventilator outlet can be adjusted in any desired direction by rotating the entire outlet. Rear seat ventilation airflow may be closed off completely, or partially closed, according to the amount of airflow desired, by rotating an adjustment knob protruding from the center of the outlet.

## PITOT-STATIC SYSTEM AND INSTRUMENTS

The pitot-static system supplies ram air pressure to the airspeed indicator and static pressure to the airspeed indicator, vertical speed indicator and altimeter. The system is composed of either an unheated or heated pitot tube mounted on the lower surface of the left wing, two external static ports on the left and right sides of the forward fuselage, and the associated plumbing necessary to connect the instruments to the sources.

The heated pitot system (if installed) consists of a heating element in the pitot tube, a rocker switch labeled PITOT HT and a 10-amp push-to reset circuit breaker on the left side of the switch and control panel, and associated wiring. When the pitot heat switch is turned on, the element in the pitot tube is heated electrically to maintain proper operation in possible icing conditions. Pitot heat should be used only as required.

A static pressure alternate source valve may be installed beneath the throttle, and can be used if the external static source is malfunctioning. This valve supplies static pressure from inside the cabin instead of the external static ports.

If erroneous instrument readings are suspected due to water or ice in the pressure line going to the standard external static pressure source, the

alternate static source valve should be pulled on.

Pressures within the cabin will vary with heater/vents opened or closed and windows open. Refer to Sections 3 and 5 for the effect of varying cabin pressures on airspeed and altimeter readings.

## AIRPEED INDICATOR

The airspeed indicator is calibrated in knots and miles per hour. Limitation and range markings (in KIAS) include the white arc (42 to 100 knots), green arc (50 to 145 knots), yellow arc (145 to 164 knots), and a red line (164 knots).

If a true airspeed indicator is installed, it is equipped with a rotatable ring which works in conjunction with the airspeed indicator dial in a manner similar to the operation of a flight computer. To operate the indicator, first rotate the ring until **pressure** altitude is aligned with outside air temperature in degrees Fahrenheit. Pressure altitude should not be confused with indicated altitude. To obtain pressure altitude, momentarily set the barometric scale on the altimeter to 29.92 and read pressure altitude on the altimeter. Be sure to return the altimeter barometric scale to the original barometric setting after pressure altitude has been obtained. Having set the ring to correct for altitude and temperature, read the true airspeed shown on the rotatable ring by the indicator pointer. For best accuracy, the indicated airspeed should be corrected to calibrated airspeed by referring to the Airspeed Calibration chart in Section 5. Knowing the calibrated airspeed, read true airspeed on the ring opposite the calibrated airspeed.

## VERTICAL SPEED INDICATOR

The vertical speed indicator depicts airplane rate of climb or descent in feet per minute. The pointer is actuated by atmospheric pressure changes resulting from changes of altitude as supplied by the static source.

## ALTIMETER

Airplane altitude is depicted by a barometric type altimeter. A knob near the lower left portion of the indicator provides adjustment of the instrument's barometric scale to the current altimeter setting.

## VACUUM SYSTEM AND INSTRUMENTS

An engine-driven vacuum system (see figure 7-10) provides the suction necessary to operate the attitude indicator and directional indicator.

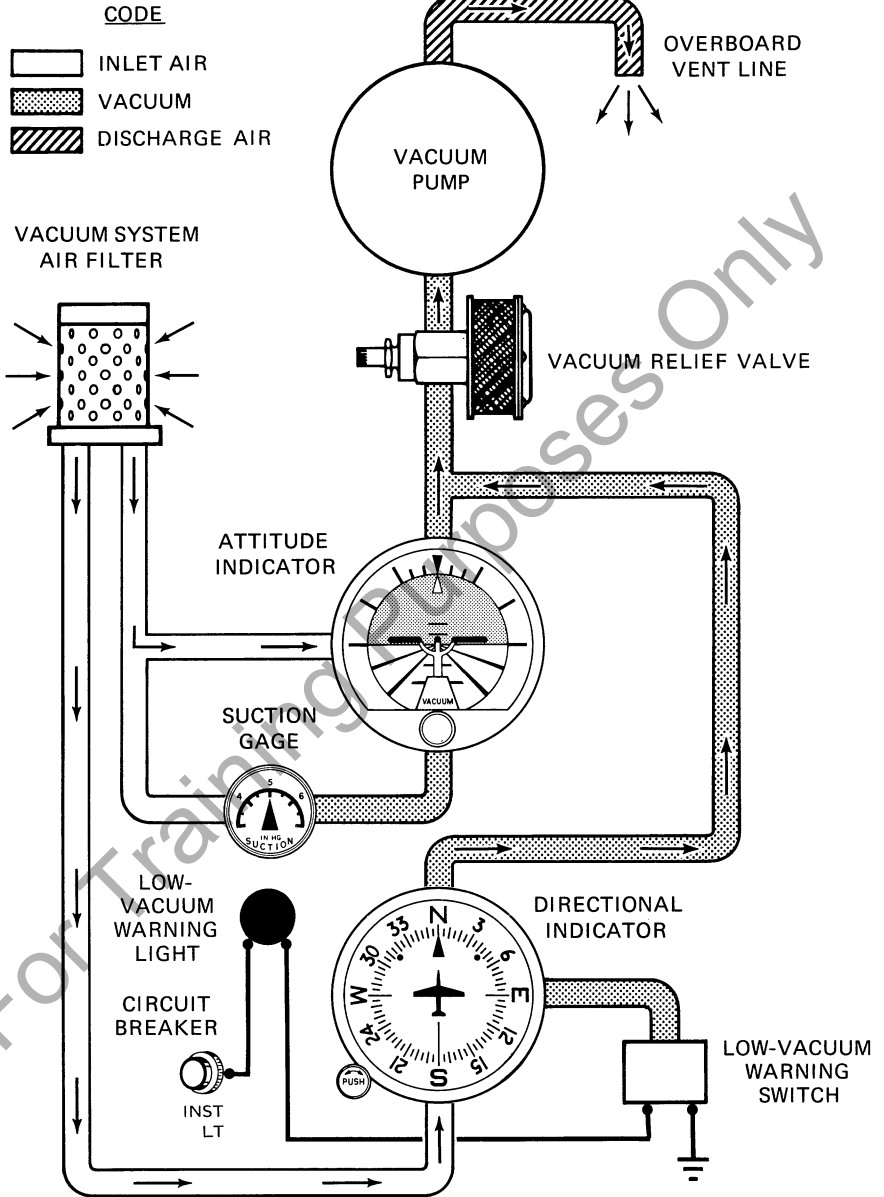

Figure 7-10. Vacuum System

The system consists of a vacuum pump mounted on the engine, a vacuum relief valve and vacuum system air filter on the aft side of the firewall below the instrument panel, vacuum-operated instruments and low-vacuum warning light on the left side of the instrument panel, and a suction gage on the left side of the panel.

## ATTITUDE INDICATOR

An attitude indicator is available and gives a visual indication of flight attitude. Bank attitude is presented by a pointer at the top of the indicator relative to the bank scale which has index marks at 10°, 20°, 30°, 60°, and 90° either side of the center mark. Pitch and roll attitudes are presented by a miniature airplane superimposed over a symbolic horizon area divided into two sections by a white horizon bar. The upper "blue sky" area and the lower "ground" area have arbitrary pitch reference lines useful for pitch attitude control. A knob at the bottom of the instrument is provided for in-flight adjustment of the miniature airplane to the horizon bar for a more accurate flight attitude indication.

## DIRECTIONAL INDICATOR

A directional indicator displays airplane heading on a compass card in relation to a fixed simulated airplane image and index. The directional indicator will precess slightly over a period of time. Therefore, the compass card should be set in accordance with the magnetic compass just prior to takeoff, and occasionally re-adjusted on extended flights. A knob on the lower left edge of the instrument is used to adjust the compass card to correct for precession.

## SUCTION GAGE

The suction gage, located at the upper left corner of the instrument panel, is calibrated in inches of mercury and indicates suction available for operation of the attitude and directional indicators. The desired suction range is 4.5 to 5.4 inches of mercury. A suction reading out of this range may indicate a system malfunction or improper adjustment, and in this case, the indicators should not be considered reliable.

## LOW-VACUUM WARNING LIGHT

A red low-vacuum warning light is installed on the instrument panel to warn the pilot of a possible low-vacuum condition existing in the vacuum system. Illumination of the light warns the pilot to check the suction gage and to be alert for possible erroneous vacuum-driven gyro instrument indications.

## STALL WARNING SYSTEM

The airplane is equipped with a vane-type stall warning unit, in the leading edge of the left wing, which is electrically connected to a dual warning unit located behind the instrument panel. The vane in the wing senses the change in airflow over the wing, and operates the dual warning unit, which produces a continuous tone over the airplane speaker at airspeeds between 5 and 10 knots above the stall in all configurations.

If the airplane has a heated stall warning system, the vane and sensor unit in the wing leading edge is equipped with a heating element. The heated part of the system is operated by the PITOT HT switch, and is protected by the PITOT HT circuit breaker.

The stall warning system should be checked during the pre-flight inspection by momentarily turning on the master switch and actuating the vane in the wing. The system is operational if a continuous tone is heard on the airplane speaker as the vane is pushed upward.

## AVIONICS SUPPORT EQUIPMENT

If the airplane is equipped with avionics, various avionics support equipment may also be installed. Equipment available includes an avionics cooling fan, microphone-headset installations and control surface static dischargers. The following paragraphs discuss these items. Description and operation of radio equipment is covered in Section 9 of this handbook.

### AVIONICS COOLING FAN

An avionics cooling fan system is provided whenever a factory-installed Nav/Com radio is installed. The system is designed to provide internal cooling air from a small electric fan to the avionics units and thereby eliminate the possibility of moisture contamination using an external cooling air source.

Power to the electric fan is supplied directly from a "pull-off" type circuit breaker, labeled STROBE, AVN FAN, located on the left switch and control panel. Hence, power is supplied to the fan anytime the master switch is ON.

### MICROPHONE-HEADSET INSTALLATIONS

Three types of microphone-headset installations are offered. The standard system provided with avionics equipment includes a hand-held

microphone and separate headset. The keying switch for this microphone is on the microphone. Two optional microphone-headset installations are also available; these feature a single-unit microphone-headset combination which permits the pilot or front passenger to conduct radio communications without interrupting other control operations to handle a hand-held microphone. One microphone-headset combination is a lightweight type without a padded headset and the other version has a padded headset. The microphone-headset combinations utilize a remote keying switch located on the left grip of the pilot's control wheel and, if an optional intercom system is installed, a second switch on the right grip of the front passenger's control wheel. The microphone and headset jacks are located on the lower left and right sides of the instrument panel. Audio to all three headsets is controlled by the individual audio selector switches and adjusted for volume level by using the selected receiver volume controls.

#### NOTE

To ensure audibility and clarity when transmitting with the hand-held microphone, always hold it as closely as possible to the lips, then key the microphone and speak directly into it.

### STATIC DISCHARGERS

If frequent IFR flights are planned, installation of wick-type static dischargers is recommended to improve radio communications during flight through dust or various forms of precipitation (rain, snow or ice crystals). Under these conditions, the build-up and discharge of static electricity from the trailing edges of the wings, rudder, elevator, propeller tips, and radio antennas can result in loss of usable radio signals on all communications and navigation radio equipment. Usually the ADF is first to be affected and VHF communication equipment is the last to be affected.

Installation of static dischargers reduces interference from precipitation static, but it is possible to encounter severe precipitation static conditions which might cause the loss of radio signals, even with static dischargers installed. Whenever possible, avoid known severe precipitation areas to prevent loss of dependable radio signals. If avoidance is impractical, minimize airspeed and anticipate temporary loss of radio signals while in these areas.

Static dischargers lose their effectiveness with age, and therefore, should be checked periodically (at least at every annual inspection) by qualified avionics technicians, etc. If testing equipment is not available, it is recommended that the wicks be replaced every two years, especially if the airplane is operated frequently in IFR conditions.



# SECTION 8

## AIRPLANE HANDLING, SERVICE & MAINTENANCE

### TABLE OF CONTENTS

	Page
Introduction . . . . .	8-3
Identification Plate . . . . .	8-3
Owner Notification System . . . . .	8-3
Publications . . . . .	8-3
Airplane File . . . . .	8-4
Airplane Inspection Periods . . . . .	8-5
FAA Required Inspections . . . . .	8-5
Cessna Progressive Care . . . . .	8-6
Cessna Customer Care Program . . . . .	8-6
Pilot Conducted Preventive Maintenance . . . . .	8-7
Alterations or Repairs . . . . .	8-7
Ground Handling . . . . .	8-8
Towing . . . . .	8-8
Parking . . . . .	8-8
Tie-Down . . . . .	8-8
Jacking . . . . .	8-8
Leveling . . . . .	8-9
Flyable Storage . . . . .	8-9
Servicing . . . . .	8-10
Oil . . . . .	8-10
Fuel . . . . .	8-12
Landing Gear . . . . .	8-15
Cleaning and Care . . . . .	8-16
Windshield-Windows . . . . .	8-16
Painted Surfaces . . . . .	8-16
Stabilizer Abrasion Boot Care . . . . .	8-17
Propeller Care . . . . .	8-17
Landing Gear Care . . . . .	8-17
Engine Care . . . . .	8-18
Interior Care . . . . .	8-18
Bulb Replacement During Flight . . . . .	8-18

For Training Purposes Only

## INTRODUCTION

This section contains factory-recommended procedures for proper ground handling and routine care and servicing of your Cessna. It also identifies certain inspection and maintenance requirements which must be followed if your airplane is to retain that new-plane performance and dependability. It is wise to follow a planned schedule of lubrication and preventive maintenance based on climatic and flying conditions encountered in your locality.

Keep in touch with your Cessna Dealer and take advantage of his knowledge and experience. He knows your airplane and how to maintain it. He will remind you when lubrications and oil changes are necessary, and about other seasonal and periodic services.

## IDENTIFICATION PLATE

All correspondence regarding your airplane should include the SERIAL NUMBER. The Serial Number, Model Number, Production Certificate Number (PC) and Type Certificate Number (TC) can be found on the Identification Plate, located on the left forward doorpost. Located adjacent to the Identification Plate is a Finish and Trim Plate which contains a code describing the interior color scheme and exterior paint combination of the airplane. The code may be used in conjunction with an applicable Parts Catalog if finish and trim information is needed.

## OWNER NOTIFICATION SYSTEM

As the owner of a Cessna, you will receive applicable Cessna Owner Advisories at no charge. These Owner Advisories will be mailed to owners of record. A subscription service for Service Information Letters is available directly from the Cessna Customer Services Department. Your Cessna Dealer will be glad to supply you with details concerning this subscription program, and stands ready, through his Service Department, to supply you with fast, efficient, low-cost service.

## PUBLICATIONS

Various publications and flight operation aids are furnished in the

airplane when delivered from the factory. These items are listed below.

- CUSTOMER CARE PROGRAM BOOK
- PILOT'S OPERATING HANDBOOK AND FAA APPROVED AIRPLANE FLIGHT MANUAL
- PILOT'S CHECKLISTS
- POWER COMPUTER
- WORLDWIDE CUSTOMER CARE DIRECTORY

The following additional publications, plus many other supplies that are applicable to your airplane, are available from your Cessna Dealer.

- INFORMATION MANUAL (Contains Pilot's Operating Handbook Information)
- SERVICE MANUALS AND PARTS CATALOGS FOR YOUR:  
AIRPLANE  
ENGINE AND ACCESSORIES  
AVIONICS AND AUTOPILOT

Your Cessna Dealer has a Customer Care Supplies Catalog covering all available items, many of which he keeps on hand. He will be happy to place an order for any item which is not in stock.

**NOTE**

A Pilot's Operating Handbook and FAA Approved Airplane Flight Manual which is lost or destroyed may be replaced by contacting your Cessna Dealer or writing directly to the Customer Services Department, Cessna Aircraft Company, Wichita, Kansas. An affidavit containing the owner's name, airplane serial number and registration number must be included in replacement requests since the Pilot's Operating Handbook and FAA Approved Airplane Flight Manual is identified for specific airplanes only.

## AIRPLANE FILE

There are miscellaneous data, information and licenses that are a part of the airplane file. The following is a checklist for that file. In addition, a periodic check should be made of the latest Federal Aviation Regulations to ensure that all data requirements are met.

- A. To be displayed in the airplane at all times:
1. Aircraft Airworthiness Certificate (FAA Form 8100-2).
  2. Aircraft Registration Certificate (FAA Form 8050-3).
  3. Aircraft Radio Station License, if transmitter installed (FCC Form 556).
- B. To be carried in the airplane at all times:
1. Pilot's Operating Handbook and FAA Approved Airplane Flight Manual.
  2. Weight and Balance, and associated papers (latest copy of the Repair and Alteration Form, FAA Form 337, if applicable).
  3. Equipment List.
- C. To be made available upon request:
1. Airplane Log Book.
  2. Engine Log Book.

Most of the items listed are required by the United States Federal Aviation Regulations. Since the Regulations of other nations may require other documents and data, owners of airplanes not registered in the United States should check with their own aviation officials to determine their individual requirements.

Cessna recommends that these items, plus the Pilot's Checklists, Power Computer, Customer Care Program book and Customer Care Card, be carried in the airplane at all times.

## AIRPLANE INSPECTION PERIODS

### FAA REQUIRED INSPECTIONS

As required by Federal Aviation Regulations, all civil aircraft of U.S. registry must undergo a complete inspection (annual) each twelve calendar months. In addition to the required ANNUAL inspection, aircraft operated commercially (for hire) must have a complete inspection every 100 hours of operation.

The FAA may require other inspections by the issuance of airworthiness directives applicable to the airplane, engine, propeller and components. It is the responsibility of the owner/operator to ensure compliance with all applicable airworthiness directives and, when the inspections are repetitive, to take appropriate steps to prevent inadvertent noncompliance.

In lieu of the 100 HOUR and ANNUAL inspection requirements, an airplane may be inspected in accordance with a progressive inspection schedule, which allows the work load to be divided into smaller operations that can be accomplished in shorter time periods.

The CESSNA PROGRESSIVE CARE PROGRAM has been developed to provide a modern progressive inspection schedule that satisfies the complete airplane inspection requirements of both the 100 HOUR and ANNUAL inspections as applicable to Cessna airplanes. The program assists the owner in his responsibility to comply with all FAA inspection requirements, while ensuring timely replacement of life-limited parts and adherence to factory-recommended inspection intervals and maintenance procedures.

### **CESSNA PROGRESSIVE CARE**

The Cessna Progressive Care Program has been designed to help you realize maximum utilization of your airplane at a minimum cost and downtime. Under this program, your airplane is inspected and maintained in four operations at 50-hour intervals during a 200-hour period. The operations are recycled each 200 hours and are recorded in a specially provided Aircraft Inspection Log as each operation is conducted.

The Cessna Aircraft Company recommends Progressive Care for airplanes that are being flown 200 hours or more per year, and the 100-hour inspection for all other airplanes. The procedures for the Progressive Care Program and the 100-hour inspection have been carefully worked out by the factory and are followed by the Cessna Dealer Organization. The complete familiarity of Cessna Dealers with Cessna equipment and factory-approved procedures provides the highest level of service possible at lower cost to Cessna owners.

Regardless of the inspection method selected by the owner, he should keep in mind that FAR Part 43 and FAR Part 91 establishes the requirement that properly certified agencies or personnel accomplish all required FAA inspections and most of the manufacturer recommended inspections.

### **CESSNA CUSTOMER CARE PROGRAM**

Specific benefits and provisions of the CESSNA WARRANTY plus other important benefits for you are contained in your CUSTOMER CARE PROGRAM book supplied with your airplane. You will want to thoroughly review your Customer Care Program book and keep it in your airplane at all times.

An initial inspection and either a Progressive Care Operation No. 1 or the first 100-hour inspection will be performed within the first 6 months

of ownership at no charge to you. If you take delivery from your Dealer, the initial inspection will have been performed before delivery of the airplane to you. If you pick up your airplane at the factory, plan to take it to your Dealer within 30 days after you take delivery, so the initial inspection may be performed allowing the Dealer to make any minor adjustments which may be necessary.

You will also want to return to your Dealer either at 50 hours for your first Progressive Care Operation, or at 100 hours for your first 100-hour inspection depending on which program you choose to establish for your airplane. While these important inspections will be performed for you by any Cessna Dealer, in most cases you will prefer to have the Dealer from whom you purchased the airplane accomplish this work.

## PILOT CONDUCTED PREVENTIVE MAINTENANCE

A certified pilot who owns or operates an airplane not used as an air carrier is authorized by FAR Part 43 to perform limited maintenance on his airplane. Refer to FAR Part 43 for a list of the specific maintenance operations which are allowed.

### NOTE

Pilots operating airplanes of other than U.S. registry should refer to the regulations of the country of certification for information on preventive maintenance that may be performed by pilots.

A Service Manual should be obtained prior to performing any preventive maintenance to ensure that proper procedures are followed. Your Cessna Dealer should be contacted for further information or for required maintenance which must be accomplished by appropriately licensed personnel.

## ALTERATIONS OR REPAIRS

It is essential that the FAA be contacted **prior to** any alterations on the airplane to ensure that airworthiness of the airplane is not violated. Alterations or repairs to the airplane must be accomplished by licensed personnel.

## GROUND HANDLING

### TOWING

The airplane is most easily and safely maneuvered by hand with the tow-bar attached to the nose wheel. The tow bar is stowed under the rear seat with the handle secured behind the forward seat legs. When inserted under the front of the seat and positioned in this manner, it is held secure in maneuvering flight. When towing with a vehicle, do not exceed the nose gear turning angle of 30° either side of center, or damage to the gear will result. If the airplane is towed or pushed over a rough surface during hangaring, watch that the normal cushioning action of the nose strut does not cause excessive vertical movement of the tail and the resulting contact with low hangar doors or structure. A flat nose tire or deflated strut will also increase tail height.

### PARKING

When parking the airplane, head into the wind and set the parking brakes. Do not set the parking brakes during cold weather when accumulated moisture may freeze the brakes, or when the brakes are overheated. Close the cowl flaps, install the control wheel lock and chock the wheels. In severe weather and high wind conditions, tie the airplane down as outlined in the following paragraph.

### TIE-DOWN

Proper tie-down procedure is the best precaution against damage to the parked airplane by gusty or strong winds. To tie-down the airplane securely, proceed as follows:

1. Set the parking brake and install the control wheel lock.
2. Install a surface control lock over the fin and rudder.
3. Tie sufficiently strong ropes or chains (700 pounds tensile strength) to the wing and tail tie-down fittings and secure each rope to a ramp tie-down.
4. Tie a rope (no chains or cables) to the nose gear torque link and secure to a ramp tie-down.
5. Install a pitot tube cover.

### JACKING

When a requirement exists to jack one or both main gear, the entire airplane should be jacked by using the wing jack points. Refer to the Service Manual for specific procedures and equipment required.

If nose gear maintenance is required, the nose wheel may be raised off



the ground by pressing down on a tailcone bulkhead, just forward of the horizontal stabilizer, and allowing the tail to rest on the tail tie-down ring.

#### **NOTE**

Do not apply pressure on the elevator or outboard stabilizer surfaces. When pushing on the tailcone, always apply pressure at a bulkhead to avoid buckling the skin.

To assist in raising and holding the nose wheel off the ground, weight down the tail by placing sand-bags, or suitable weights, on each side of the horizontal stabilizer, next to the fuselage. If ground anchors are available, the tail should be securely tied down.

#### **NOTE**

Ensure that the nose will be held off the ground under all conditions by means of suitable stands or supports under weight supporting bulkheads near the nose of the airplane.

### **LEVELING**

Longitudinal leveling of the airplane is accomplished by placing a level on the leveling screws located on the left side of the tailcone. Deflate the nose tire and/or lower or raise the nose strut to properly center the bubble in the level. Corresponding points on both upper door sills may be used to level the airplane laterally.

### **FLYABLE STORAGE**

Airplanes placed in non-operational storage for a maximum of 30 days or those which receive only intermittent operational use for the first 25 hours are considered in flyable storage status. Every seventh day during these periods, the propeller should be rotated by hand through five revolutions. This action "limbers" the oil and prevents any accumulation of corrosion on engine cylinder walls.

#### **WARNING**

For maximum safety, check that the ignition switch is OFF, the throttle is closed, the mixture control is in the idle cut-off position, and the airplane is secured before rotating the propeller by hand. Do not stand within the arc of the propeller blades while turning the propeller.

After 30 days, the airplane should be flown for 30 minutes or a ground runup should be made just long enough to produce an oil temperature within the lower green arc range. Excessive ground runup should be avoided.

Engine runup also helps to eliminate excessive accumulations of water in the fuel system and other air spaces in the engine. Keep fuel tanks full to minimize condensation in the tanks. Keep the battery fully charged to prevent the electrolyte from freezing in cold weather. If the airplane is to be stored temporarily, or indefinitely, refer to the Service Manual for proper storage procedures.

## SERVICING

In addition to the PREFLIGHT INSPECTION covered in Section 4, COMPLETE servicing, inspection, and test requirements for your airplane are detailed in the Service Manual. The Service Manual outlines all items which require attention at 50, 100, and 200 hour intervals plus those items which require servicing, inspection, and/or testing at special intervals.

Since Cessna Dealers conduct all service, inspection, and test procedures in accordance with applicable Service Manuals, it is recommended that you contact your Cessna Dealer concerning these requirements and begin scheduling your airplane for service at the recommended intervals.

Cessna Progressive Care ensures that these requirements are accomplished at the required intervals to comply with the 100-hour or ANNUAL inspection as previously covered.

Depending on various flight operations, your local Government Aviation Agency may require additional service, inspections, or tests. For these regulatory requirements, owners should check with local aviation officials where the airplane is being operated.

For quick and ready reference, quantities, materials, and specifications for frequently used service items are as follows:

### OIL

#### OIL SPECIFICATION --

**MIL-L-6082 Aviation Grade Straight Mineral Oil:** Used when the airplane was delivered from the factory and should be used to replenish the supply during the first 25 hours. This oil should be drained after the first 25 hours of operation. Refill the engine and continue to use until a total of 50 hours has accumulated or oil consumption has stabilized.

**MIL-L-22851 Aviation Grade Ashless Dispersant Oil:** Oil conforming to Avco Lycoming Service Instruction No. 1014, and all revisions and supplements thereto, **must be used** after 50 hours or oil consumption has stabilized.

**RECOMMENDED VISCOSITY FOR TEMPERATURE RANGE --**

All temperatures, use multi-viscosity oil or

Above 16°C (60°F), use SAE 50

-1°C (30°F) to 32°C (90°F), use SAE 40

-18°C (0°F) to 21°C (70°F), use SAE 30

**NOTE**

When operating temperatures overlap, use the lighter grade of oil.

**CAPACITY OF ENGINE SUMP -- 8 Quarts.**

Do not operate on less than 5 quarts. To minimize loss of oil through breather, fill to 7 quart level for normal flights of less than 3 hours. For extended flight, fill to 8 quarts. These quantities refer to oil dipstick level readings. During oil and filter changes, one additional quart is required.

**OIL AND OIL FILTER CHANGE --**

After the first 25 hours of operation, drain the engine oil sump and replace the filter. Refill sump with straight mineral oil and use until a total of 50 hours has accumulated or oil consumption has stabilized; then change to dispersant oil. Drain the engine oil sump and replace the oil filter again at the first 50 hours; thereafter, the oil and filter change may be extended to 100-hour intervals. Change engine oil and replace filter at least every 6 months even though less than the recommended hours have accumulated. Reduce intervals for prolonged operation in dusty areas, cold climates, or when short flights and long idle periods result in sludging conditions.

**NOTE**

During the first 25-hour oil and filter change, a general inspection of the overall engine compartment is required. Items which are not normally checked during a preflight inspection should be given special attention. Hoses, metal lines and fittings should be inspected for signs of oil and fuel leaks, and checked for abrasions, chafing, security, proper routing and support, and evidence of deterioration. Inspect the intake and exhaust systems for cracks, evidence of leakage, and security of attachment. Engine controls and linkages should be checked for freedom of movement through their full range, security of attachment and evidence of wear. Inspect wiring for security, chafing, burning, defective insulation, loose or broken terminals, heat deterioration, and corroded terminals. Check the alternator belt in accordance with Service Manual instructions, and retighten if necessary. A periodic check of these

items during subsequent servicing operations is recommended.

## FUEL

### APPROVED FUEL GRADES (AND COLORS) --

100LL Grade Aviation Fuel (Blue).

100 (Formerly 100/130) Grade Aviation Fuel (Green).

#### NOTE

Isopropyl alcohol or ethylene glycol monomethyl ether may be added to the fuel supply in quantities not to exceed 1% or .15% by volume, respectively, of the total. Refer to Fuel Additives in later paragraphs for additional information.

CAPACITY EACH TANK -- 33.0 Gallons.

REDUCED CAPACITY EACH TANK (WHEN FILLED TO BOTTOM OF FUEL FILLER COLLAR) -- 24.0 Gallons.

#### NOTE

Service the fuel system after each flight, and keep fuel tanks full to minimize condensation in the tanks.

#### NOTE

To ensure maximum fuel capacity when refueling, and minimize cross-feeding when parked on a sloping surface, place the fuel selector valve handle in either LEFT or RIGHT position.

### FUEL ADDITIVES --

Strict adherence to recommended preflight draining instructions as called for in Section 4 will eliminate any free water accumulations from the tank sumps. While small amounts of water may still remain in solution in the gasoline, it will normally be consumed and go unnoticed in the operation of the engine.

One exception to this can be encountered when operating under the combined effect of: (1) use of certain fuels, with (2) high humidity conditions on the ground (3) followed by flight at high altitude and low temperature. Under these unusual conditions, small amounts of water in solution can precipitate from the fuel stream and freeze in sufficient quantities to induce partial icing of the engine fuel system.

While these conditions are quite rare and will not normally pose a problem to owners and operators, they do exist in certain areas of the world and consequently must be dealt with, when encountered.

Therefore, to alleviate the possibility of fuel icing occurring under these unusual conditions, it is permissible to add isopropyl alcohol or ethylene glycol monomethyl ether (EGME) compound to the fuel supply.

The introduction of alcohol or EGME compound into the fuel provides two distinct effects: (1) it absorbs the dissolved water from the gasoline and (2) alcohol has a freezing temperature depressant effect.

Alcohol, if used, is to be blended with the fuel in a concentration of 1% by volume. Concentrations greater than 1% are not recommended since they can be detrimental to fuel tank materials.

The manner in which the alcohol is added to the fuel is significant because alcohol is most effective when it is completely dissolved in the fuel. To ensure proper mixing, the following is recommended:

1. For best results, the alcohol should be added during the fueling operation by pouring the alcohol directly on the fuel stream issuing from the fueling nozzle.
2. An alternate method that may be used is to premix the complete alcohol dosage with some fuel in a separate clean container (approximately 2-3 gallon capacity) and then transferring this mixture to the tank prior to the fuel operation.

Any high quality isopropyl alcohol may be used, such as Anti-Icing Fluid (MIL-F-5566) or Isopropyl Alcohol (Federal Specification TT-I-735a). Figure 8-1 provides alcohol-fuel mixing ratio information.

Ethylene glycol monomethyl ether (EGME) compound, in compliance with MIL-I-27686 or Phillips PFA-55MB, if used, must be carefully mixed with the fuel in concentrations not to exceed .15% by volume. Figure 8-1 provides EGME-fuel mixing ratio information.

### CAUTION

Mixing of the EGME compound with the fuel is extremely important because a concentration in excess of that recommended (.15% by volume maximum) will result in detrimental effects to the fuel tanks, such as deterioration of protective primer and sealants and damage to O-rings and

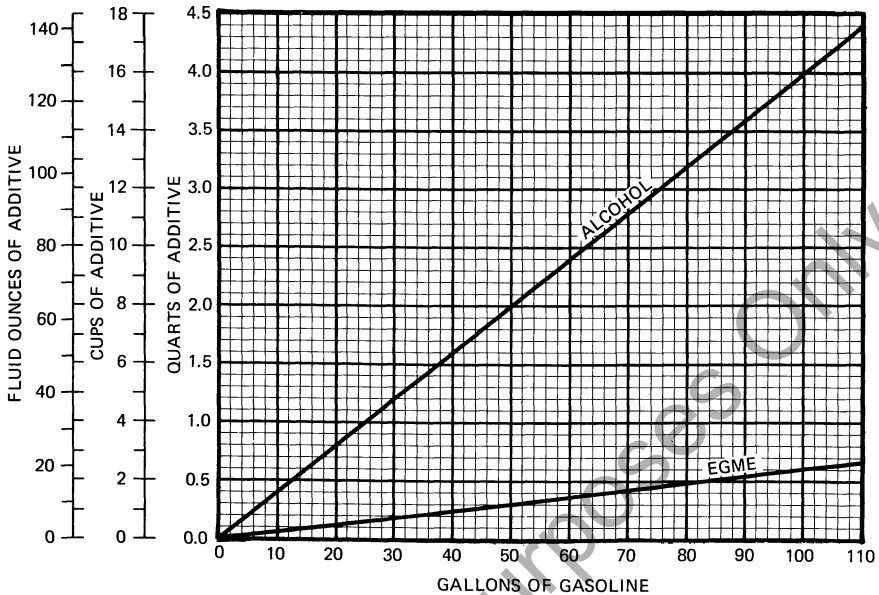

Figure 8-1. Additive Mixing Ratio

seals in the fuel system and engine components. Use only blending equipment that is recommended by the manufacturer to obtain proper proportioning.

### CAUTION

Do not allow the concentrated EGME compound to come in contact with the airplane finish or fuel cell as damage can result.

Prolonged storage of the airplane will result in a water buildup in the fuel which "leeches out" the additive. An indication of this is when an excessive amount of water accumulates in the fuel tank sumps. The concentration can be checked using a differential refractometer. It is imperative that the technical manual for the differential refractometer be followed explicitly when checking the additive concentration.

### FUEL CONTAMINATION --

Fuel contamination is usually the result of foreign material present in the fuel system, and may consist of water, rust, sand, dirt, microbes or bacterial growth. In addition, additives that are not compatible with

fuel or fuel system components can cause the fuel to become contaminated.

Before the first flight of the day and after each refueling, use a clear sampler cup and drain a cupful of fuel from the fuel tank sump, fuel strainer, and fuel selector quick-drain valves to determine if contaminants are present, and that the airplane has been fueled with the proper grade of fuel.

If contamination is detected, continue draining from all fuel drain points until all contamination has been removed. If the airplane has been serviced with the improper fuel grade, defuel completely and refuel with the correct grade. **Do not** fly the airplane with contaminated or unapproved fuel.

In addition, Owners/Operators who are not acquainted with a particular fixed base operator should be assured that the fuel supply has been checked for contamination and is properly filtered before allowing the airplane to be serviced. Also, fuel tanks should be kept full between flights, provided weight and balance considerations will permit, to reduce the possibility of water condensing on the walls of partially filled tanks.

To further reduce the possibility of contaminated fuel, routine maintenance of the fuel system should be performed in accordance with the airplane Service Manual. Only the proper fuel, as recommended in this handbook, should be used, and fuel additives should not be used unless approved by Cessna and the Federal Aviation Administration.

## LANDING GEAR

NOSE WHEEL TIRE PRESSURE -- 40-50 PSI on 5.00-5, 6-Ply Rated Tire.  
MAIN WHEEL TIRE PRESSURE -- 60-68 PSI on 15 x 6.00-6, 6-Ply Rated Tires.

NOSE GEAR SHOCK STRUT --

Keep filled with MIL-H-5606 hydraulic fluid per filling instructions placard, and with no load on the strut, inflate with air to 55 PSI. Do not over-inflate.

HYDRAULIC FLUID RESERVOIR -- Check every 25 hours and service with MIL-H-5606 hydraulic fluid.

BRAKES -- Service as required with MIL-H-5606 hydraulic fluid.

## CLEANING AND CARE

### WINDSHIELD-WINDOWS

The plastic windshield and windows should be cleaned with an aircraft windshield cleaner. Apply the cleaner sparingly with soft cloths, and rub with moderate pressure until all dirt, oil scum and bug stains are removed. Allow the cleaner to dry, then wipe it off with soft flannel cloths.

If a windshield cleaner is not available, the plastic can be cleaned with soft cloths moistened with Stoddard solvent to remove oil and grease.

#### NOTE

**Never use** gasoline, benzine, alcohol, acetone, fire extinguisher or anti-ice fluid, lacquer thinner or glass cleaner to clean the plastic. These materials will attack the plastic and may cause it to craze.

Follow by **carefully** washing with a mild detergent and plenty of water. Rinse thoroughly, then dry with a clean moist chamois. **Do not rub** the plastic with a dry cloth since this builds up an electrostatic charge which attracts dust. Waxing with a good commercial wax will finish the cleaning job. A thin, even coat of wax, polished out by hand with clean soft flannel cloths, will fill in minor scratches and help prevent further scratching.

**Do not use** a canvas cover on the windshield unless freezing rain or sleet is anticipated since the cover may scratch the plastic surface.

### PAINTED SURFACES

The painted exterior surfaces of your new Cessna have a durable, long lasting finish. Approximately 10 days are required for the paint to cure completely; in most cases, the curing period will have been completed prior to delivery of the airplane. In the event that polishing or buffing is required within the curing period, it is recommended that the work be done by someone experienced in handling uncured paint. Any Cessna Dealer can accomplish this work.

Generally, the painted surfaces can be kept bright by washing with water and mild soap, followed by a rinse with water and drying with cloths or a chamois. Harsh or abrasive soaps or detergents which cause corrosion or scratches should never be used. Remove stubborn oil and grease with a cloth moistened with Stoddard solvent.

To seal any minor surface chips or scratches and protect against corrosion, the airplane should be waxed regularly with a good automotive wax



applied in accordance with the manufacturer's instructions. If the airplane is operated in a seacoast or other salt water environment, it must be washed and waxed more frequently to assure adequate protection. Special care should be taken to seal around rivet heads and skin laps, which are the areas most susceptible to corrosion. A heavier coating of wax on the leading edges of the wings and tail and on the cowl nose cap and propeller spinner will help reduce the abrasion encountered in these areas. Reapplication of wax will generally be necessary after cleaning with soap solution or after chemical de-icing operations.

When the airplane is parked outside in cold climates and it is necessary to remove ice before flight, care should be taken to protect the painted surfaces during ice removal with chemical liquids. Isopropyl alcohol will satisfactorily remove ice accumulations without damaging the paint. However, keep the isopropyl alcohol away from the windshield and cabin windows since it will attack the plastic and may cause it to craze.

### **STABILIZER ABRASION BOOT CARE**

If the airplane is equipped with stabilizer abrasion boots, keep them clean and free from oil and grease which can swell the rubber. Wash them with mild soap and water, using Form Tech AC cleaner or naphtha to remove stubborn grease. Do not scrub the boots, and be sure to wipe off all solvent before it dries. Boots with loosened edges or small tears should be repaired. Your Cessna Dealer has the proper materials and know-how to do this correctly.

### **PROPELLER CARE**

Preflight inspection of propeller blades for nicks, and wiping them occasionally with an oily cloth to clean off grass and bug stains will assure long blade life. Small nicks on the propeller, particularly near the tips and on the leading edges, should be dressed out as soon as possible since these nicks produce stress concentrations, and if ignored, may result in cracks. Never use an alkaline cleaner on the blades; remove grease and dirt with Stoddard solvent.

### **LANDING GEAR CARE**

Cessna Dealers' mechanics have been trained in the proper adjustment and rigging procedures on the airplane hydraulic system. To assure trouble-free gear operation, have your Cessna Dealer check the gear regularly and make any necessary adjustments. Only properly trained mechanics should attempt to repair or adjust the landing gear.

## ENGINE CARE

The engine may be cleaned, using a suitable solvent, in accordance with instructions in the airplane Service Manual. Most efficient cleaning is done using a spray-type cleaner. Before spray cleaning, ensure that protection is afforded for components which might be adversely affected by the solvent. Refer to the Service Manual for proper lubrication of controls and components after engine cleaning.

## INTERIOR CARE

To remove dust and loose dirt from the upholstery and carpet, clean the interior regularly with a vacuum cleaner.

Blot up any spilled liquid promptly with cleansing tissue or rags. Don't pat the spot; press the blotting material firmly and hold it for several seconds. Continue blotting until no more liquid is taken up. Scrape off sticky materials with a dull knife, then spot-clean the area.

Oily spots may be cleaned with household spot removers, used sparingly. Before using any solvent, read the instructions on the container and test it on an obscure place on the fabric to be cleaned. Never saturate the fabric with a volatile solvent; it may damage the padding and backing materials.

Soiled upholstery and carpet may be cleaned with foam-type detergent, used according to the manufacturer's instructions. To minimize wetting the fabric, keep the foam as dry as possible and remove it with a vacuum cleaner.

If your airplane is equipped with leather seating, cleaning of the seats is accomplished using a soft cloth or sponge dipped in mild soap suds. The soap suds, used sparingly, will remove traces of dirt and grease. The soap should be removed with a clean damp cloth.

The plastic trim, headliner, instrument panel and control knobs need only be wiped off with a damp cloth. Oil and grease on the control wheel and control knobs can be removed with a cloth moistened with Stoddard solvent. Volatile solvents, such as mentioned in paragraphs on care of the windshield, must never be used since they soften and craze the plastic.

## BULB REPLACEMENT DURING FLIGHT

Figure 8-2 provides instructions to aid the pilot in the replacement of

defective light bulbs during flight without tools. It is suggested that spare bulbs be stored in the map compartment. However, if a spare bulb is not available, an identical bulb which is found to be available from other lights listed herein can be substituted for the defective bulb. For a listing of other bulb requirements and specific tools needed, refer to the Service Manual for this airplane.

#### DOORPOST MOUNTED MAP LIGHT

Remove lens retainer by pulling straight out from housing. To remove either bulb, push forward and turn counterclockwise as far as possible, then pull bulb straight out of socket. Replace with S2243-1 clear, or S2243-2 red bulb as required. To install new bulb in socket, align pins on bulb with slots in socket, then push forward and rotate bulb clockwise as far as possible. Push lens retainer straight on housing until dimples on retainer seat into holes in housing.

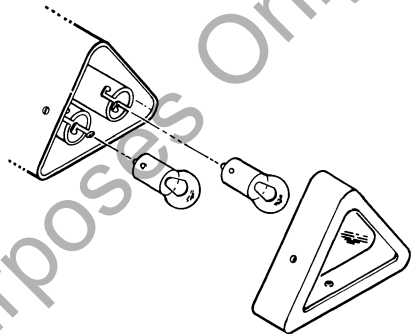

#### POST LIGHTS

Grasp lens cap and pull straight out from socket. Pull bulb from cap and replace with MS25237-327 bulb. Replace cap in socket and rotate cap to direct light in desired direction.

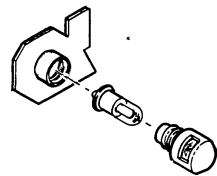

#### LANDING GEAR LIGHTS

Remove lens cap by turning counterclockwise until it separates from housing. Pull bulb from back side of lens cap and replace with MS25237-327 bulb. Replace lens cap by turning it clockwise until hand-tight. After replacing lens cap, check that dimming shutter is not closed. Replacement procedure is identical for "gear up" and "gear down" lights, and either bulb (or a post light bulb) may be used to replace the other, if a spare bulb is not available.

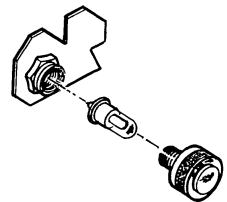

Figure 8-2. Bulb Replacement

For Training Purposes Only

# SECTION 9 SUPPLEMENTS

## (Optional Systems Description & Operating Procedures)

### TABLE OF CONTENTS

#### Introduction

##### General:

- 1 Carburetor Air Temperature Gage . . . . . (2 pages)
- 2 Digital Clock . . . . . (4 pages)
- 3 Ground Service Plug Receptacle . . . . . (4 pages)
- 4 Strobe Light System . . . . . (2 pages)
- 5 Winterization Kit . . . . . (2 pages)

##### Avionics:

- 6 Audio Control Panels . . . . . (8 pages)
- 7 DME (Type 450C) . . . . . (4 pages)
- 8 Emergency Locator Transmitter (ELT) . . . . . (4 pages)
- 9 RNAV (Type ANS-351C) . . . . . (14 pages)
- 10 SSB HF Transceiver (Type ASB-125) . . . . . (4 pages)
- 11 200A Navomatic Autopilot (Type AF-295B) . . . . . (8 pages)
- 12 300 ADF (Type R-546E) . . . . . (6 pages)
- 13 300 Nav/Com (Type RT-385A) . . . . . (8 pages)
- 14 300 Transponder (Type RT-359A) And Optional  
Altitude Encoder (Blind) . . . . . (6 pages)
- 15 300 Transponder (Type RT-359A) And Optional  
Encoding Altimeter (Type EA-401A) . . . . . (6 pages)
- 16 300A Navomatic Autopilot (Type AF-395A) . . . . . (8 pages)
- 17 400 Glide Slope (Type R-443B) . . . . . (4 pages)
- 18 400 Marker Beacon (Type R-402) . . . . . (6 pages)
- 19 400 Transponder (Type RT-459A) And Optional  
Altitude Encoder (Blind) . . . . . (6 pages)
- 20 400 Transponder (Type RT-459A) And Optional  
Encoding Altimeter (Type EA-401A) . . . . . (6 pages)

## INTRODUCTION

This section consists of a series of supplements, each covering a single optional system which may be installed in the airplane. Each supplement contains a brief description, and when applicable, operating limitations, emergency and normal procedures, and performance. As listed in the Table of Contents, the supplements are classified under the headings of General and Avionics, and have been provided with reference numbers. Also, the supplements are arranged alphabetically and numerically to make it easier to locate a particular supplement. Other routinely installed items of optional equipment, whose function and operational procedures do not require detailed instructions, are discussed in Section 7.

Limitations contained in the following supplements are FAA approved. Observance of these operating limitations is required by Federal Aviation Regulations.

## **SUPPLEMENT**

# **CARBURETOR AIR TEMPERATURE GAGE**

### **SECTION 1 GENERAL**

The carburetor air temperature gage provides a means of detecting carburetor icing conditions. The gage is located on the upper right corner of the instrument panel. It is marked in 5° increments from -30°C to +30°C, and has a yellow arc between -15°C and +5°C which indicates the temperature range most conducive to carburetor icing.

### **SECTION 2 LIMITATIONS**

There is no change to the airplane limitations when the carburetor air temperature gage is installed.

### **SECTION 3 EMERGENCY PROCEDURES**

There is no change to the airplane emergency procedures when the carburetor air temperature gage is installed.

## **SECTION 4**

### **NORMAL PROCEDURES**

There is no change to the airplane normal procedures when the carburetor air temperature gage is installed. It is good practice to monitor the gage periodically and keep the needle out of the yellow arc during possible carburetor icing conditions. Refer to Section 4 of the basic handbook for procedures used when operating with carburetor heat applied.

## **SECTION 5**

### **PERFORMANCE**

There is no change to the airplane performance when the carburetor air temperature gage is installed. However, if it is necessary to operate with carburetor heat applied, a small performance loss may be expected at any given power setting due to the warmer induction air temperature.



# **SUPPLEMENT**

## **DIGITAL CLOCK**

### **SECTION 1**

#### **GENERAL**

The Astro Tech LC-2 Quartz Chronometer (see figure 1) is a precision, solid state time keeping device which will display to the pilot the time-of-day, the calendar date, and the elapsed time interval between a series of selected events, such as in-flight check points or legs of a cross-country flight, etc. These three modes of operation function independently and can be alternately selected for viewing on the four digit liquid crystal display (LCD) on the front face of the instrument. Three push button type switches directly below the display control all time keeping functions. These control functions are summarized in figures 2 and 3.

The digital display features an internal light (back light) to ensure good visibility under low cabin lighting conditions or at night. The intensity of the back light is controlled by the RADIO LT rheostat. In addition, the display incorporates a test function (see figure 1) which allows checking that all elements of the display are operating. To activate the test function, press the LH and RH buttons at the same time.

### **SECTION 2**

#### **LIMITATIONS**

There is no change to the airplane limitations when the digital clock is installed.

### **SECTION 3**

#### **EMERGENCY PROCEDURES**

There is no change to the airplane emergency procedures when the digital clock is installed.

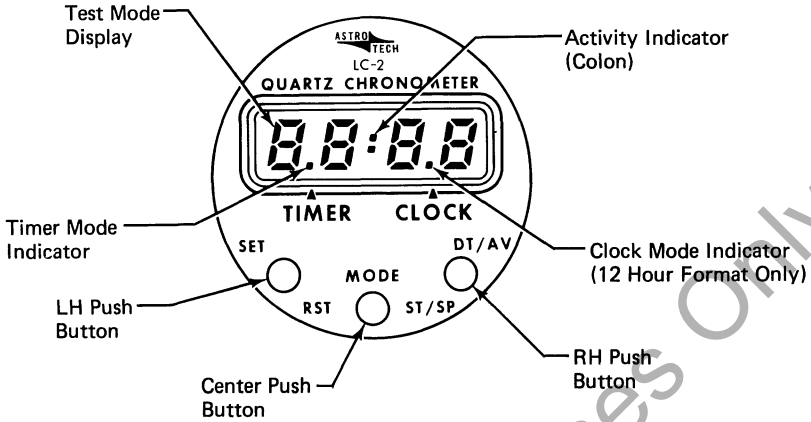

Figure 1. Digital Clock

## SECTION 4

### NORMAL PROCEDURES

#### CLOCK AND DATE OPERATION

When operating in the clock mode (see figure 2), the display shows the time of day in hours and minutes while the activity indicator (colon) will blink off for one second each ten seconds to indicate proper functioning. If the RH push button is pressed momentarily, while in the clock mode, the calendar date appears numerically on the display with month of year to the left of the colon and day of the month shown to the right of the colon. The display automatically returns to the clock mode after approximately 1.5 seconds. However, if the RH button is pressed continuously longer than approximately two seconds, the display will return from the date to the clock mode with the activity indicator (colon) blinking altered to show continuously or be blanked completely from the display. Should this occur, simply press the RH button again for two seconds or longer, and correct colon blinking will be restored.

#### NOTE

The clock mode is set at the factory to operate in the 24-hour format. However, 12-hour format operation may be selected by changing the position of an internal slide switch accessible through a small hole on the bottom of the instrument case. Notice that in the 24-hour format, the clock mode indicator does not appear.

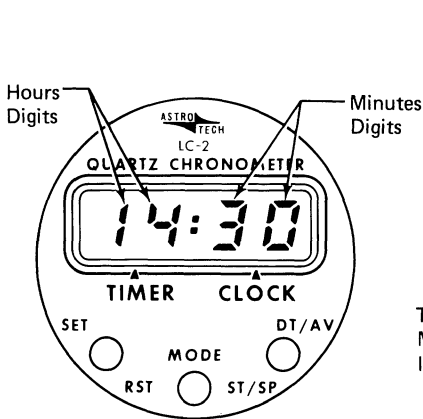

LH Button: Sets date and time of day (when used with RH button).

Center Button: Alternately displays clock or timer status

RH Button: Shows calendar date momentarily; display returns to clock mode after 1.5 seconds.

Figure 2. Clock Mode

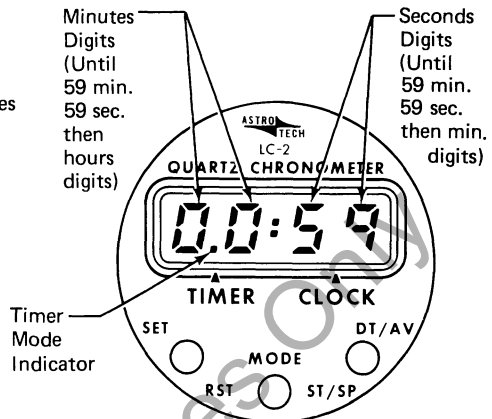

LH Button: Resets timer to "zero".

Center Button: Alternately displays clock or timer status

RH Button: Alternately starts and stops timer; timer starts from any previously accumulated total.

Figure 3. Timer Mode

## SETTING CORRECT DATE AND TIME

The correct date and time are set while in the clock mode using the LH and RH push buttons as follows: press the LH button once to cause the date to appear with the month flashing. Press the RH button to cause the month to advance at one per second (holding button), or one per push until the correct month appears. Push the LH button again to cause the day of month to appear flashing, then advance as before using RH button until correct day of month appears.

Once set correctly, the date advances automatically at midnight each day. February 29 of each leap year is not programmed into the calendar mode, and the date will advance to March 1. This may be corrected the following day by resetting the mode back to March 1.

Pressing the LH button two additional times will cause the time to appear with the hours digits flashing. Using the RH button as before, advance the hour digits to the correct hour as referenced to a known time standard. Another push of the LH button will now cause the minutes digits to flash. Advance the minutes digits to the next whole minute to be reached by the time standard and "hold" the display by pressing the LH button once more. At the exact instant the time standard reaches the value "held" by the display, press the RH button to restart normal clock timing, which will now be synchronized to the time standard.

In some instances, however, it may not be necessary to advance the minutes digits of the clock; for example when changing time zones. In such a case, do not advance the minutes digits while they are flashing. Instead, press the LH button again, and the clock returns to the normal time keeping mode without altering the minutes timing.

#### TIMER OPERATION

The completely independent 24-hour elapsed timer (see figure 3) is operated as follows: press the center (MODE) push button until the timer mode indicator appears. Reset the display to "zero" by pressing the LH button. Begin timing an event by pressing the RH button. The timer will begin counting in minutes and seconds and the colon (activity indicator) will blink off for 1/10 second each second. When 59 minutes 59 seconds have accumulated, the timer changes to count in hours and minutes up to a maximum of 23 hours, 59 minutes. During the count in hours and minutes, the colon blinks off for one second each ten seconds. To stop timing the event, press the RH button once again and the time shown by the display is "frozen". Successive pushes of the RH button will alternately restart the count from the "held" total or stop the count at a new total. The hold status of the timer can be recognized by lack of colon activity, either continuously on or continuously off. The timer can be reset to "zero" at anytime using the LH button.

## SECTION 5 PERFORMANCE

There is no change to the airplane performance when the digital clock is installed.

# SUPPLEMENT

## GROUND SERVICE PLUG RECEPTACLE

### SECTION 1 GENERAL

The ground service plug receptacle permits the use of an external power source for cold weather starting and during lengthy maintenance work on the electrical and avionics equipment. The receptacle is located behind a door on the left side of the fuselage aft of the baggage compartment door.

#### NOTE

If no avionics equipment is to be used or worked on, the avionics power switch should be turned off. If maintenance is required on the avionics equipment, it is advisable to utilize a battery cart external power source to prevent damage to the avionics equipment by transient voltage. Do not crank or start the engine with the avionics power switch turned on.

A special fused circuit is included with the ground service plug receptacle which will close the battery contactor when external power is applied with the master switch turned on. This circuit is intended as a servicing aid when battery power is too low to close the contactor, and should not be used to avoid performing proper maintenance procedures on a low battery.

#### NOTE

Use of the ground service plug receptacle for starting an airplane with a "dead" battery or charging a "dead" battery in the airplane is not recommended. The battery should be removed from the airplane and serviced in accordance with Service Manual procedures. Failure to observe this precaution could result in loss of electrical power during flight.

## **SECTION 2**

### **LIMITATIONS**

The following information must be presented in the form of a placard located on the inside of the ground service plug access door:

<p><b>CAUTION</b>                      <b>24 VOLTS D.C.</b> This aircraft is equipped with alternator and a negative ground system. <b>OBSERVE PROPER POLARITY</b> Reverse polarity will damage electrical components.</p>
--

## **SECTION 3**

### **EMERGENCY PROCEDURES**

There is no change to the airplane emergency procedures when the ground service plug receptacle is installed.

## **SECTION 4**

### **NORMAL PROCEDURES**

Just before connecting an external power source (generator type or battery cart), the avionics power switch should be turned off, and the master switch turned on.

#### **WARNING**

When turning on the master switch, using an external power source, or pulling the propeller through by hand, treat the propeller as if the ignition switch were ON. Do not stand, nor allow anyone else to stand, within the arc of the propeller, since a loose or broken wire or a component malfunction could cause the propeller to rotate.

The ground service plug receptacle circuit incorporates a polarity reversal protection. Power from the external power source will flow only if the ground service plug is correctly connected to the airplane. If the plug is accidentally connected backwards, no power will flow to the electrical system, thereby preventing any damage to electrical equipment.

The following check should be made after engine start and removal of the external power source, if there is any question as to the condition of the battery.

1. Master Switch -- OFF.
2. Taxi and Landing Light Switches -- ON.
3. Engine RPM -- REDUCE to idle.
4. Master Switch -- ON (with taxi and landing lights turned on).
5. Engine RPM -- INCREASE to approximately 1500 RPM.
6. Ammeter and Low-Voltage Warning Light -- CHECK.

#### NOTE

If the ammeter does not show a charge or the low-voltage warning light does not go out, the battery should be removed from the airplane and properly serviced prior to flight.

## SECTION 5 PERFORMANCE

There is no change to the airplane performance when the ground service plug receptacle is installed.

For Training Purposes Only



# SUPPLEMENT

## STROBE LIGHT SYSTEM

### SECTION 1 GENERAL

The high intensity strobe light system enhances anti-collision protection for the airplane. The system consists of two wing tip-mounted strobe lights (with integral power supplies), a two-position rocker switch, labeled STROBE LT, and a 5-amp "pull-off" type circuit breaker, labeled STROBE/AVN FAN. The rocker switch and circuit breaker are located on the left side of the switch and control panel.

### SECTION 2 LIMITATIONS

Strobe lights must be turned off when taxiing in the vicinity of other airplanes, or during night flight through clouds, fog or haze.

### SECTION 3 EMERGENCY PROCEDURES

There is no change to the airplane emergency procedures when strobe lights are installed.

## **SECTION 4**

### **NORMAL PROCEDURES**

To operate the strobe light system, proceed as follows:

1. Master Switch -- ON.
2. Strobe Light Switch -- ON.

## **SECTION 5**

### **PERFORMANCE**

The installation of strobe lights will result in a minor reduction in cruise performance.

For Training Purposes Only

# SUPPLEMENT

## WINTERIZATION KIT

### SECTION 1 GENERAL

The winterization kit consists of two cover plates (with placards) which attach to the air intakes in the cowling nose cap, a restrictive cover plate for the aft side of the oil cooler, insulation for the engine crankcase breather line, and a placard to be installed on the instrument panel. This equipment should be installed for operations in temperatures consistently below 20°F (-7°C). Once installed, the crankcase breather insulation is approved for permanent use, regardless of temperature. The attachment brackets for the nose cap cover plates may be left installed for the winter season, but must be removed for warm weather operation.

### SECTION 2 LIMITATIONS

The following information is presented in the form of placards when the airplane is equipped with a winterization kit.

1. On each nose cap cover plate and oil cooler cover:

REMOVE WHEN  
OAT EXCEEDS 20°F

2. On right hand nose cap cover plate:

REMOVE OIL COOLER COVER PLATE  
FROM AFT SIDE OF OIL COOLER  
WHEN OAT EXCEEDS 20°F

3. On right side of instrument panel:

WINTERIZATION KIT (RIGHT AND LEFT NOSE-CAP COVER AND OIL COOLER COVER PLATE) MUST BE REMOVED WHEN THE OUTSIDE AIR TEMPERATURE IS ABOVE 20°F.

### **SECTION 3**

## **EMERGENCY PROCEDURES**

There is no change to the airplane emergency procedures when the winterization kit is installed.

### **SECTION 4**

## **NORMAL PROCEDURES**

There is no change to the airplane normal procedures when the winterization kit is installed.

### **SECTION 5**

## **PERFORMANCE**

There is no change to the airplane performance when the winterization kit is installed.

# SUPPLEMENT

## AUDIO CONTROL PANELS

### SECTION 1

#### GENERAL

Two types of audio control panels (see figure 1) are available for this airplane, depending upon how many transmitters are included. The operational features of both audio control panels are similar and are discussed in the following paragraphs.

#### TRANSMITTER SELECTOR SWITCH

When the avionics package includes a maximum of two transmitters, a two-position toggle-type switch, labeled XMTR, is provided to switch the microphone to the transmitter the pilot desires to use. If the airplane avionics package includes a third transmitter, the transmitter selector switch is a three-position rotary-type switch, labeled XMTR SEL. To select a transmitter, place the transmitter selector switch in the position number corresponding to the desired transmitter.

The action of selecting a particular transmitter using the transmitter selector switch simultaneously selects the audio amplifier associated with that transmitter to provide speaker audio. For example, if the number one transmitter is selected, the audio amplifier in the number one NAV/COM is also selected and is used for ALL speaker audio. Headset audio is not affected by audio amplifier operation.

#### AUDIO SELECTOR SWITCHES

Both audio control panels (see figure 1) incorporate three-position toggle-type audio selector switches for individual control of the audio systems installed in the airplane. These switches allow receiver audio to be directed to the airplane speaker or to a headset, and heard singly or in combination with other receivers. To hear a particular receiver on the airplane speaker, place that receiver's audio selector switch in the up (SPEAKER) position. To listen to a receiver over a headset, place that receiver's audio selector switch in the down (PHONE) position. The center (OFF) position turns off all audio from the associated receiver.

#### NOTE

Volume level is adjusted using the individual receiver volume controls on each radio.

A special feature of the audio control panel used when one or two transmitters are installed is separate control of NAV and COM audio from the NAV/COM radios. With this installation, the audio selector switches labeled NAV, 1 and 2 select audio only from the navigation receivers of the NAV/COM radios. Communication receiver audio is selected by the switches labeled COM, AUTO and BOTH. Description and operation of these switches is described in figure 1.

When the audio control panel for three transmitters is installed, audio from both NAV and COM frequencies is combined, and is selected by the audio selector switches labeled NAV/COM, 1, 2 and 3.

#### COM AUTO AUDIO SELECTOR SWITCH

The audio control panel used with either one or two transmitters incorporates a three-position toggle switch, labeled COM AUTO, which is provided to automatically match the audio of the appropriate NAV/COM communications receiver to the radio selected by the transmitter selector switch.

#### COM BOTH AUDIO SELECTOR SWITCH

The audio control panel used with either one or two transmitters incorporates a three-position toggle switch, labeled COM BOTH, which is provided to allow both COM receivers to be monitored at the same time.

#### AUTO AUDIO SELECTOR SWITCH

The audio control panel used with three transmitters incorporates a three-position toggle switch, labeled AUTO, which is provided to automatically match the audio of the appropriate NAV/COM receiver to the selected transmitter.

#### ANNUNCIATOR LIGHTS BRIGHTNESS AND TEST SWITCH

The audio control panel used with either one or two transmitters incorporates a three-position toggle switch with NITE (up) and DAY (middle) positions to control the brightness level of the marker beacon indicator lights, and the BC, LOC, ARC and RN Nav indicator lights (when installed). In the TEST (down) position, all marker beacon annunciator lights will illuminate full bright to verify bulb operation.

#### NOTE

A potentiometer is installed inside the audio control panel to provide further minimum light dimming capabilities. Refer to the appropriate Avionics Service/Parts manual for adjustment procedures.

## SIDETONE OPERATION

Cessna radios are equipped with sidetone capability (monitoring of the operator's own voice transmission). While adjusting speaker sidetone, be aware that if the sidetone volume level is set too high, audio feedback (squeal) may result when transmitting.

When the airplane has one or two transmitters, sidetone is provided in either the speaker or headset anytime the COM AUTO selector switch is utilized. Placing the COM AUTO selector switch in the OFF position will eliminate sidetone. Sidetone internal adjustments are available to the pilot through the front of the audio control panel (see figure 1).

When the airplane has three transmitters, sidetone will be heard on either the speaker or a headset as selected with the AUTO selector switch. Sidetone may be eliminated by placing the AUTO selector switch in the OFF position, and utilizing the individual audio selector switches. Adjustment of speaker and headset sidetone volume can only be accomplished by adjusting the sidetone potentiometers located inside the audio control panel.

### NOTE

Sidetone is not available on HF Transceiver (Type ASB-125), when installed.

## OPTIONAL INTERCOM SYSTEM

The optional intercom system is a pilot and copilot intercom phone system which is only offered with the one and two transmitter type audio control panel. The system incorporates its own audio amplifier with a volume control (labeled INT) and a "hot mike" feature. The intercom system is used with the headphones only.

The "hot mike" feature allows the pilot and copilot to communicate at anytime through their microphone/headsets without having to key the mike. However, they must key the mike button on their control wheel to transmit over the aircraft's transceiver. Sidetone is present on the intercom system when the COM AUTO switch is in the PHONE position.

### NOTE

Any ambient noise attenuating type padded headset and boom mike combination may not be compatible with this system.

The intercom audio volume is controlled by the INT knob located on the front of the audio control panel. Clockwise rotation of the knob increases the volume of the intercom audio and counterclockwise rotation decreases it. The INT knob controls the audio volume for the intercom system only. Receiver audio volume is adjusted using the individual receiver volume controls. When the intercom system is not being used, the INT volume control should be turned full counterclockwise to eliminate any noise over the headphones.

#### NOTE

When the intercom volume is turned up and an auxiliary mike is plugged in, there will be a loud squeal over the speaker if the COM BOTH and COM AUTO switches are inadvertently placed in the opposite positions (one in the SPEAKER position and the other in the PHONE position). To eliminate this squeal turn the volume down or place both switches in the same position.

When the optional intercom system is not installed, a plug button will be installed in place of the INT volume control knob.



USED WITH ONE OR TWO TRANSMITTERS

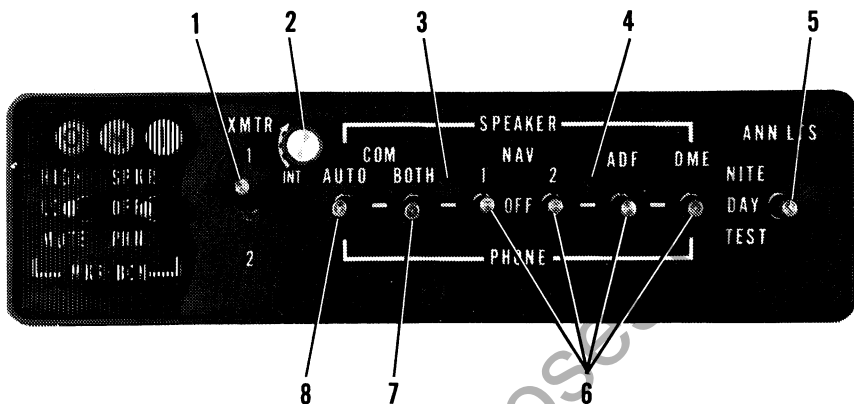

USED WITH THREE TRANSMITTERS OR DUAL ADF'S

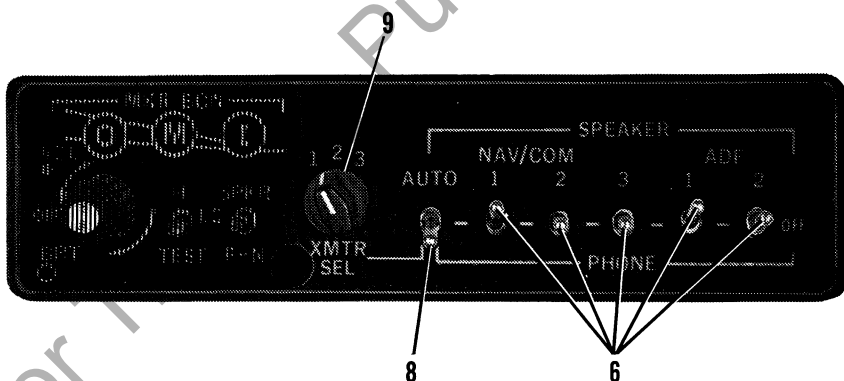

1. TRANSMITTER SELECTOR SWITCH (XMTR) - A two-position toggle switch used to activate the audio amplifier and switch the microphone to the desired transmitter. The number 1 (up position) and 2 (down position) corresponds to the first and second (from top to bottom) transmitters, respectively.

Figure 1. Audio Control Panel Operating Controls  
(Sheet 1 of 2)

2. INTERCOM VOLUME CONTROL (INT) - Controls the intercom audio volume. Clockwise rotation of the knob increases the intercom audio volume and counterclockwise rotation decreases it.
3. HEADSET SIDETONE INTERNAL ADJUSTMENT ACCESS - To adjust headset sidetone, remove the plug button, place COM AUTO selector switch in the PHONE position, insert a small screwdriver into the adjustment potentiometer and rotate it clockwise to increase the sidetone volume or counterclockwise to decrease sidetone.
4. SPEAKER SIDETONE INTERNAL ADJUSTMENT ACCESS - To adjust speaker sidetone, remove the plug button, place COM AUTO selector switch in the SPEAKER position, insert a small screwdriver into the adjustment potentiometer and rotate it clockwise to increase the sidetone volume or counterclockwise to decrease sidetone. While adjusting sidetone, be aware that if the sidetone volume level is set too high, audio feedback (squeal) may result when transmitting.
5. ANNUNCIATOR LIGHTS BRIGHTNESS SELECTOR AND TEST SWITCH (ANN LTS-NITE/DAY/TEST) - Three-position toggle switch; in the up (NITE) position, annunciator lights (Mkr Bcn, BC, LOC, ARC and RN) will show at a reduced light level for typical night operations. In the NITE position, annunciator light (Mkr Bcn, BC, LOC, ARC and RN) level can be further adjusted down to a preset minimum using the RADIOLT dimming rheostat knob. In the center (DAY) position, annunciator lights (Mkr Bcn, BC, LOC, ARC, and RN) will show full bright. In the TEST position, the Mkr Bcn lights will show full bright to verify lamp operation.
6. AUDIO SELECTOR SWITCHES - Three-position selector switches used to select either SPEAKER or PHONE operation for audio outputs. Enables the operator to select any one or more, audio signals on either SPEAKER or PHONE at the same time or to silence audio when placed in the OFF position.
7. COM BOTH AUDIO SELECTOR SWITCH (COM BOTH) - A three-position toggle switch used to allow both COM receivers to be monitored at the same time. Placing the COM BOTH switch in the up (SPEAKER) position will enable the pilot to monitor both the number 1 and number 2 COM receivers over the SPEAKER at the same time. Placing the switch in the down (PHONE) position allows the pilot to monitor both the number 1 and number 2 COM receivers through the headset at the same time. Center (OFF) position, removes the non-selected COM receiver (or both COM receivers if COM AUTO switch is OFF) from the audio system.
8. COM AUTO AUDIO SELECTOR SWITCH (COM AUTO OR AUTO) - A three-position toggle switch provided to automatically match the audio of the appropriate NAV/COM communications receiver to the transmitter selected by the transmitter selector switch. In the up (SPEAKER) position, audio from the selected receiver will be heard on the airplane speaker. In the down (PHONE) position, audio from the selected receiver will be heard through the headset. Center (OFF) position, removes the automatic SPEAKER/PHONE selection feature and will also disable the sidetone feature.
9. TRANSMITTER SELECTOR SWITCH (XMTR SEL) - A three-position rotary switch used to activate the audio amplifier and switch the microphone to the desired transmitter. The numbers 1, 2 and 3 positions correspond to the first, second and third (from top to bottom) transmitters, respectively.

Figure 1. Audio Control Panel Operating Controls  
(Sheet 2 of 2)

## SECTION 2 LIMITATIONS

There is no change to the airplane limitations when either of these audio control panels is installed.

## SECTION 3 EMERGENCY PROCEDURES

In the event the audio amplifier in use fails, as evidenced by loss of all speaker audio, selecting an alternate transmitter will reestablish speaker audio using the alternate transmitter audio amplifier.

## SECTION 4 NORMAL PROCEDURES

### AUDIO CONTROL PANEL OPERATIONS:

1. Transmitter Selector (XMTR or XMTR SEL) Switch -- SELECT desired transmitter for transceiver operation.
2. COM AUTO or AUTO Selector Switch -- SELECT SPEAKER or PHONE position to automatically select SPEAKER or PHONE audio.

### NOTE

If the NAV/COM audio selector switch corresponding to the selected transmitter is in the PHONE position with the AUTO selector switch in the SPEAKER position, all audio selector switches placed in the PHONE position will automatically be connected to both the airplane speaker and any headsets in use.

3. COM BOTH Selector Switch -- SELECT the same SPEAKER or PHONE position which was set on the COM AUTO selector switch to allow both COM receivers to be monitored at the same time.

#### NOTE

The combination of placing the COM AUTO switch in the SPEAKER position and the COM BOTH switch in the PHONE position (or vice versa) is not normally recommended as it will cause audio from both communications receivers (and any other navigation receiver with its audio selector switch in the PHONE position) to be heard on both the airplane speaker and the headset simultaneously.

4. Audio SPEAKER/PHONE Selector Switches -- SELECT desired SPEAKER or PHONE audio position only if COM AUTO switch is not used.
5. INT Control Knob -- ROTATE as desired to increase or decrease intercom audio volume.
6. ANN LTS Switch:
  - a. TEST Position -- SELECT to verify operation of marker beacon annunciator lights (when installed).
  - b. DAY Position -- SELECT for typical daytime lighting.
  - c. NITE Position -- SELECT for typical night lighting.

#### NOTE

In the NITE position, further lighting adjustment for the Mkr Bcn, BC, LOC, ARC and RN (when installed) annunciator lights can be obtained using the RADIOLT dimming rheostat knob.

## SECTION 5 PERFORMANCE

There is no change to the airplane performance when either of these audio control panels is installed.

# SUPPLEMENT

## DME

### (TYPE 450C WITH IND-450C INDICATOR)

#### SECTION 1

#### GENERAL

The DME-450C system consists of a panel-mounted IND-450C Indicator, a remotely-mounted TCR-451 Transceiver and an externally-mounted antenna.

Except for selection of the operating channel, which is selected by the VHF navigation receiver frequency selector switches, the DME-450C system is capable of independent operation. The DME-450C transmits interrogating pulse pairs on 200 channels between 1041 MHz and 1150 MHz; it receives associated ground-to-air replies between 978 MHz and 1213 MHz. The IND-450C digitally displays distances to or from the selected station up to 200 nautical miles, aircraft ground speed from 30 to 399 knots, or time-to-station with a maximum time of 120 minutes. A Nav mode selector switch provides selection of ON/OFF, Nav 1, Nav 2, Hold and RNAV operation. A DME display selector switch provides selection of distance to or from station (NM), aircraft ground speed (KTS) or time-to-station (MIN). An ambient light sensor automatically controls brightness of digital display and annunciators.

#### SECTION 2 LIMITATIONS

There is no change to the airplane limitations when this avionics equipment is installed.

#### SECTION 3 EMERGENCY PROCEDURES

There is no change to the airplane emergency procedures when this avionics equipment is installed.



1. AMBIENT LIGHT SENSOR - Senses ambient cockpit light and controls brightness of digital display and WPT and HLD annunciators.
2. DIGITAL DISPLAY - Displays distance to or from station (NM), aircraft ground speed (KTS), or time-to-station (MIN), depending on the position of the display selector (3).

## NOTE

Dashes will be observed on the display until station lock-on occurs in the NM mode or until a velocity of at least 30 knots is established with lock-on in the KTS or MIN mode.

## NOTE

In all DME modes, aircraft ground speed and time-to-station are meaningful only when the aircraft track is directly to or from the ground station or the waypoint in RNAV mode. The KTS and MIN indications require approximately 1.5 minutes after station acquisition for final accuracy.

3. DME DISPLAY SELECTOR SWITCH - Selects desired mode readouts as follows:
  - NM Position: Displays distance to or from the selected station in nautical miles up to 199.9 nmi.
  - KTS Position: Displays aircraft ground speed up to 399 knots.
  - MIN Position: Displays time-to-station with a maximum time of 120 minutes.

Brightness of this switch is controlled by the radio light dimming rheostat.

Figure 1. IND-450C Indicator  
(Sheet 1 of 2)

4. NAV MODE SELECTOR SWITCH - Applies power to the DME and selects DME operating modes as follows:
  - OFF: Turns the DME OFF.
  - NAV 1: Selects DME operation with No. 1 VHF navigation set; enables channel selection by Nav 1 frequency selector switches.
  - HOLD: Selects DME memory circuit; DME remains channeled to station to which it was last channeled when HOLD was selected and will continue to display information relative to this channel. Allows both the Nav 1 and Nav 2 navigation receivers to be set to new operational frequencies without affecting the previously selected DME operation.

**CAUTION**

In the Hold mode there is no annunciation of the VOR/DME station frequency. However, an annunciator labeled "HLD" will illuminate on the DME to flag the pilot that the DME is in the Hold mode.

- NAV 2: Selects DME operation with No. 2 VHF navigation set; enables channel selection by Nav 2 frequency selector switches.
- RNAV: Selects area navigation operation.

Brightness of this switch is controlled by the radio light dimming rheostat.

5. HOLD ANNUNCIATOR (HLD) - Illuminates amber to indicate HOLD mode is selected.
6. WAYPOINT ANNUNCIATOR (WPT) - Illuminates amber to indicate RNAV mode is selected. (Annunciator will not illuminate when DME is installed without RNAV.)

Figure 1. IND-450C Indicator  
(Sheet 2 of 2)

## SECTION 4

### NORMAL PROCEDURES

#### DME OPERATION

1. NAV 1 and NAV 2 VHF Navigation Receivers -- ON; SET frequency selector switches to VOR/DME station frequencies as required.
2. NAV Mode Selector Switch -- SET to NAV 1 or NAV 2.

#### NOTE

When the VOR frequency is selected, the appropriate DME frequency is automatically channeled.

3. DME SPEAKER/PHONE Selector Switch (on audio control panel) -- SET to desired mode to identify station ident tone.
4. DME Display Selector Switch -- SELECT desired readout.

#### DME HOLD FUNCTION:

The HOLD position is selected when the currently controlling Nav receiver (1 or 2) frequency is about to be changed but the pilot wishes the DME to remain operating on the current frequency after the navigation frequency has been changed.

1. NAV Mode Selector Switch -- SELECT HOLD.

#### CAUTION

Inadvertent switching to any other DME Nav Mode position other than HOLD must be avoided, since this will channel the DME to a new frequency as determined by the appropriate Nav frequency selected.

2. NAV 1 or NAV 2 Receiver -- SELECT new operating frequency.

## SECTION 5

### PERFORMANCE

There is no change to the airplane performance when this avionic equipment is installed. However, the installation of an externally-mounted antenna or several related external antennas, will result in a minor reduction in cruise performance.



# SUPPLEMENT

## EMERGENCY LOCATOR TRANSMITTER (ELT)

### SECTION 1 GENERAL

The ELT consists of a self-contained dual-frequency radio transmitter and battery power supply, and is activated by an impact of 5g or more as may be experienced in a crash landing. The ELT emits an omni-directional signal on the international distress frequencies of 121.5 and 243.0 MHz. General aviation and commercial aircraft, the FAA, and CAP monitor 121.5 MHz, and 243.0 MHz is monitored by the military. Following a crash landing, the ELT will provide line-of-sight transmission up to 100 miles at 10,000 feet. The ELT transmits on both distress frequencies simultaneously at 75 mw rated power output for 48 continuous hours in the temperature range of -4°F to +131°F (-20°C to +55°C).

The ELT is readily identified as a bright orange unit mounted on the right hand side of the baggage compartment wall in the tailcone. To gain access to the unit, remove the cover. The ELT is operated by a control panel at the forward facing end of the unit (see figure 1).

### SECTION 2 LIMITATIONS

The following information must be presented in the form of a placard located on the baggage compartment wall.

EMERGENCY LOCATOR TRANSMITTER  
INSTALLED BEHIND THIS COVER.  
MUST BE SERVICED IN ACCORDANCE  
WITH FAR 91.52

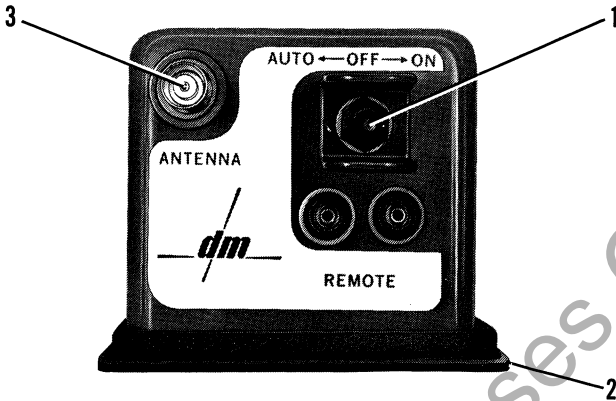

1. FUNCTION SELECTOR SWITCH (3-position toggle switch):  
AUTO - Activates transmitter only when "g" switch receives 5g or more impact.  
OFF - Deactivates transmitter. Used during shipping, storage and following rescue.  
ON - Activates transmitter instantly. Used for test purposes and if "g" switch is inoperative.
2. COVER - Removable for access to battery pack.
3. ANTENNA RECEPTACLE - Connects to antenna mounted on top of tailcone.

Figure 1. ELT Control Panel

## SECTION 3

### EMERGENCY PROCEDURES

Immediately after a forced landing where emergency assistance is required, the ELT should be utilized as follows.

1. ENSURE ELT ACTIVATION --Turn a radio transceiver ON and select 121.5 MHz. If the ELT can be heard transmitting, it was activated by the "g" switch and is functioning properly. If no emergency tone is audible, gain access to the ELT and place the function selector switch in the ON position.

2. PRIOR TO SIGHTING RESCUE AIRCRAFT -- Conserve airplane battery. Do not activate radio transceiver.
3. AFTER SIGHTING RESCUE AIRCRAFT -- Place ELT function selector switch in the OFF position, preventing radio interference. Attempt contact with rescue aircraft with the radio transceiver set to a frequency of 121.5 MHz. If no contact is established, return the function selector switch to ON immediately.
4. FOLLOWING RESCUE -- Place ELT function selector switch in the OFF position, terminating emergency transmissions.

## SECTION 4 NORMAL PROCEDURES

As long as the function selector switch remains in the AUTO position, the ELT automatically activates following an impact of 5g or more over a short period of time.

Following a lightning strike, or an exceptionally hard landing, the ELT may activate although no emergency exists. To check your ELT for inadvertent activation, select 121.5 MHz on your radio transceiver and listen for an emergency tone transmission. If the ELT can be heard transmitting, place the function selector switch in the OFF position and the tone should cease. Immediately place the function selector switch in the AUTO position to re-set the ELT for normal operation.

## SECTION 5 PERFORMANCE

There is no change to the airplane performance data when this equipment is installed.

For Training Purposes Only

# **SUPPLEMENT**

## **AREA NAVIGATION SYSTEM**

### **(TYPE ANS-351C)**

#### **SECTION 1**

#### **GENERAL**

The Area Navigation System (Type ANS-351C) consists of an ANS-351C Area Navigation Computer, a compatible Cessna 300 or 400 Series VHF navigation receiver with a course deviation indicator, and a DME-450C System with an IND-450C Indicator.

There are two types of Course Deviation Indicators which may be used with this Area Navigation System. Either a type IN-442AR Indicator with VOR/LOC capabilities, or a type IN-443AR Indicator with VOR/LOC/ILS capabilities may be coupled with the No. 2 navigation receiver. These 400 Series Indicators are not equipped with a course datum synchro to provide course datum information to the autopilot.

#### **NOTE**

This is the only installation in which a 400 Series Radio and 400 Series Indicator, coupled with a slaved gyro system, are installed without Course Datum.

The ANS-351C Area Navigation Computer contains concentric rotary switches for waypoint definition entry, an eight-waypoint number selector, an enroute/approach sensitivity control, use and return pushbuttons for waypoint management, a check pushbutton, electronic displays for data readout, and an ambient light sensor to control brightness of digital displays and annunciators. Primary power is applied to the ANS-351C by the Number 2 VHF Navigation Receiver to which it is coupled.

The ANS-351C Area Navigation Computer calculates the following parameters when activated: Crosstrack deviation of the aircraft from the selected course and to/from information displayed on the associated CDI, and (as selected on the DME) ground speed displayed in knots, time-to-waypoint displayed in minutes, or distance-to-waypoint displayed in nautical miles.

The ANS-351C Area Navigation Computer has a built-in flag circuit which causes the waypoint display number to blink anytime a non-active waypoint is displayed. Another built-in flag circuit is built into the RNAV Computer to alert the pilot that the system is not operating in the RNAV mode and that the RNAV has electrically been eliminated from the system, making the computer transparent to all incoming data. When the DME has been switched to NAV 1, HOLD or NAV 2, the RADIAL readout will be flagged with either the word "Vor" or "Loc" to alert the pilot that RNAV mode is inactive. An additional flag circuit is provided in the CDI which causes a red OFF flag to appear anytime a non-usable VOR/DME signal is being received.

### CAUTION

If RNAV set is removed from the airplane or becomes inoperative, the associated VHF navigation indicator will be inoperative.

The DME-450C system used in conjunction with this RNAV system consists of a panel-mounted IND-450C Indicator, a remotely-mounted TCR-451 Transceiver and an externally-mounted antenna.

Except for selection of the operating channel, which is selected by the VHF navigation receiver frequency selector switches, the DME-450C system is capable of independent operation. However, only the RNAV mode is used with this RNAV system. The DME-450C transmits interrogating pulse pairs on 200 channels between 1041 MHz and 1150 MHz; it receives associated ground-to-air replies between 978 MHz and 1213 MHz. The IND-450C digitally displays distances to or from the selected station up to 200 nautical miles, aircraft ground speed from 30 to 399 knots, or time-to-station with a maximum time of 120 minutes. A Nav mode selector switch provides selection of ON/OFF, Nav 1, Nav 2, Hold and RNAV operation. A DME display selector switch provides selection of distance to or from station or waypoint (NM), aircraft ground speed (KTS) or time-to-station or waypoint (MIN). An ambient light sensor automatically controls display intensity.

All operating controls and displays which are part of the ANS-351C Area Navigation Computer, IND-450C Indicator and Course Deviation Indicators IN-442AR and IN-443AR are shown and described in Figure 1. Other controls required for operation of the ANS-351C RNAV system with DME-450C are included on the VHF Nav 2 receiver and are shown and described in the 300 and 400 Nav/Com (Types RT-385A and RT-485A) Supplements in this section.

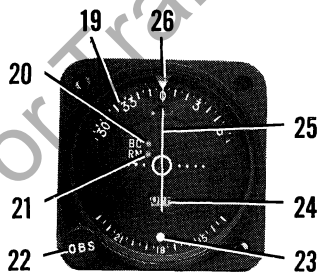
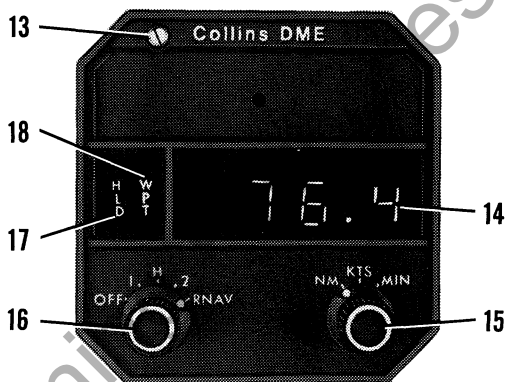
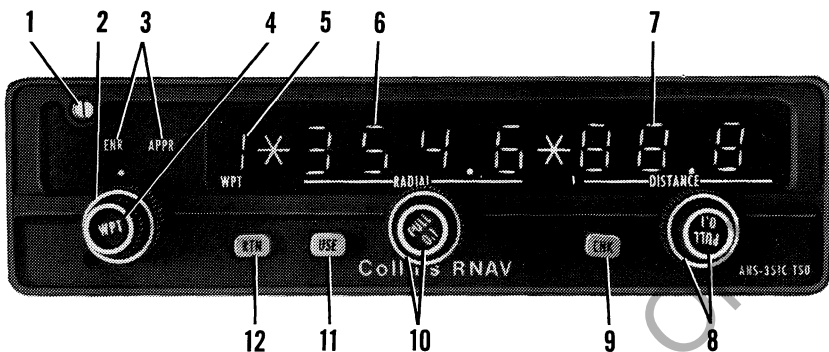

IN-442AR STANDARD VOR/LOC CDI

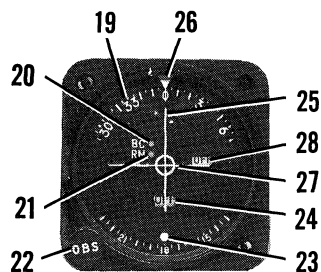

IN-443AR OPTIONAL VOR/LOC/ILS CDI

Figure 1. ANS-351C Computer, IND-450C Indicator and Associated CDI Controls (Sheet 1 of 5)

1. AMBIENT LIGHT SENSOR - Senses ambient cockpit light and controls brightness of digital displays (5, 6, 7) and ENR/APPR annunciators (3).
2. MODE CONTROL KNOB - Selects ENR (enroute) or APPR (approach) modes of operation. In the enroute mode, CDI deviation is 1 nmi/dot, 5 nmi full scale. In approach, deviation is 0.25 nmi/dot, 1 1/4 nmi full scale deflection out to 40 nmi from the waypoint.
3. ENROUTE AND APPROACH MODE ANNUNCIATOR LIGHTS (ENR/APPR) - When the annunciator light illuminates amber under either ENR or APPR modes, it indicates selection of ENR (enroute) sensitivity (1 nmi/dot) or APPR (approach) sensitivity (0.25 nmi/dot).
4. WAYPOINT SELECTOR KNOB (WPT) - Selects the desired display waypoints, from 1 through 8.
5. WAYPOINT NUMBER DISPLAY (WPT 1 thru 8) - Digitally displays (from 1 thru 8) the selected waypoint defined by the displayed data. A blinking number indicates a non-active waypoint; continuously ON number indicates the active waypoint.
6. RADIAL DISPLAY READOUT (RADIAL) - When DME is set to RNAV mode, the computer will digitally display the VOR RADIAL from the reference station on which the waypoint is located. When the DME is set to Nav 1, Hold, or Nav 2, the computer display will spell out "Vor" when a VOR frequency is selected on the Nav receiver, or "Loc" will be spelled out if a localizer frequency is selected on the Nav receiver.

NOTE

Four zeros will be displayed until desired radial data is dialed in.

7. DISTANCE DISPLAY READOUT (DISTANCE) - Digitally displays DISTANCE in nautical miles from the reference station to the waypoint.

NOTE

Three zeros will be displayed until desired distance data is dialed in.

8. DISTANCE SELECTOR KNOBS - Sets distance information in nautical miles into the display. Two concentric knobs control information as follows:

Large outer knob: Changes display in 10 nmi increments.

Small inner knob : Pushed in, changes display in 1 nmi increments.

Pulled out, changes display in 0.1 nmi increments when less than 100 nmi.

Beyond 100 nmi, changes display in 1 nmi increments.

Figure 1. ANS-351C Computer, IND-450C Indicator  
and Associated CDI Controls (Sheet 2 of 5)



9. CHECK BUTTON (CHK) - When the CHK pushbutton is pressed and held, and the DME display selector switch is in the NM position, the DME indicator will display distance from the selected DME facility rather than the waypoint. As a signal that raw data is being displayed on the DME, the waypoint annunciator on the DME will be extinguished. Exercising the check feature does not disturb the RNAV calculation, RNAV course deviation display on the CDI, to/from flag or RNAV autopilot coupling. The CHK pushbutton is spring-loaded to ensure return to the RNAV position when released. Brightness of this button is controlled by the radio light dimming rheostat.
10. RADIAL SELECTOR KNOBS - Sets information into the display. Two concentric knobs control information as follows:
  - Large outer knob: Changes display in 10° increments.
  - Small inner knob: Pushed in, changes display in 1° increments.  
Pulled out, changes display in 0.1° increments.
11. USE PUSHBUTTON - Pressing the USE pushbutton converts the displayed preview waypoint (indicated by a blinking WPT number) into the active waypoint. Brightness of this button is controlled by the radio light dimming rheostat.
12. RETURN PUSHBUTTON (RTN) - Pressing the RTN pushbutton returns the display to the previously selected active waypoint when a non-active waypoint is currently being displayed. Brightness of this button is controlled by the radio light dimming rheostat.
13. AMBIENT LIGHT SENSOR - Senses ambient cockpit light and controls brightness of digital display and WPT and HLD annunciators.
14. DIGITAL DISPLAY - Displays distance to or from station or waypoint (NM), aircraft ground speed (KTS), or time-to-station or waypoint (MIN), depending on the position of the display selector (15).

NOTE

Dashes will be observed on the display until station lock-on occurs in the NM mode or until a velocity of at least 30 knots is established with lock-on in the KTS or MIN mode.

NOTE

In all DME modes including RNAV, aircraft ground speed and time-to-station are meaningful only when the aircraft track is directly to or from the ground station or waypoint. The KTS and MIN indications require approximately 10-12 minutes in RNAV ENR mode or 4-5 minutes in the RNAV APPR mode to attain 90-95 percent final (stabilized) calculated value.

Figure 1. ANS-351C Computer, IND-450C Indicator and Associated CDI Controls (Sheet 3 of 5)

15. DME DISPLAY SELECTOR SWITCH - Selects desired mode readouts as follows:  
 NM Position: Displays distance to or from the selected station or waypoint in nautical miles up to 199.9 nmi.  
 KTS Position: Displays aircraft ground speed up to 399 knots.  
 MIN Position: Displays time-to-station or waypoint with a maximum time of 120 minutes.

Brightness of this switch is controlled by the radio light dimming rheostat.

16. NAV MODE SELECTOR SWITCH - Applies power to the DME and selects DME operating modes as follows:  
 OFF: Turns the DME OFF.  
 NAV 1: Selects DME operation with No. 1 VHF navigation set; enables channel selection by Nav 1 frequency selector switches.  
 HOLD: Selects DME memory circuit; DME remains channeled to station to which it was last channeled when HOLD was selected and will continue to display information relative to this channel. Allows both the Nav 1 and Nav 2 navigation receivers to be set to new operational frequencies without affecting the previously selected DME operation.

### CAUTION

In the Hold mode there is no annunciation of the VOR/DME station frequency. However, an annunciator labeled "HLD" will illuminate on the DME to flag the pilot that the DME is in the Hold mode.

NAV 2: Selects DME operation with No. 2 VHF navigation set; enables channel selection by Nav 2 frequency selector switches.  
 RNAV: Selects area navigation operation with the No. 2 VHF navigation set.

Brightness of this switch is controlled by the radio light dimming rheostat.

17. HOLD ANNUNCIATOR (HLD) - Illuminates amber to indicate HOLD mode is selected.
18. WAYPOINT ANNUNCIATOR (WPT) - Illuminates amber to indicate RNAV mode is selected.
19. COURSE CARD - Indicates selected VOR or RNAV course under course index.
20. BACK-COURSE LAMP (BC) - Amber light illuminates when an autopilot's back-course function is engaged and receiver is tuned to a localizer frequency; indicates course deviation pointer is reversed. Light dimming is only available when installed with an audio control panel incorporating the annunciator lights DAY/NITE selector switch.
21. AREA NAV LAMP (RN) - When green light is illuminated, indicates that RNAV operation is selected. Light dimming is only available when installed with an audio control panel incorporating the annunciator lights DAY/NITE selector switch.

Figure 1. ANS-351C Computer, IND-450C Indicator  
and Associated CDI Controls (Sheet 4 of 5)

22. OMNI BEARING SELECTOR (OBS) - Rotates course card (19) to select desired bearing to or from a VOR station or to or from a selected RNAV waypoint.
23. RECIPROCAL COURSE INDEX - Indicates reciprocal of selected VOR or RNAV course.
24. OFF/TO-FROM INDICATOR - Operates only with VOR, localizer or RNAV signal. OFF position (red flag) indicates unusable signal. With usable VOR signal, when OFF position disappears, indicates whether selected course is TO or FROM station or waypoint. With usable localizer signal, white TO flag is in view.
25. COURSE DEVIATION POINTER - Indicates course deviation from selected VOR or RNAV course or localizer centerline.
26. COURSE INDEX - Indicates selected VOR or RNAV course (bearing).
27. GLIDE SLOPE DEVIATION POINTER - Indicates deviation from ILS glide slope.
28. GLIDE SLOPE "OFF" FLAG - When visible, red OFF flag indicates unreliable glide slope signal or improperly operating equipment. Flag disappears when a reliable glide slope signal is being received.

Figure 1. ANS-351C Computer, IND-450C Indicator  
and Associated CDI Controls (Sheet 5 of 5)

## SECTION 2

### LIMITATIONS

The following RNAV IFR approach limitation must be adhered to during airplane operation.

1. IFR Approaches -- Follow approved published RNAV instrument approach procedures.

## SECTION 3

### EMERGENCY PROCEDURES

There is no change to the airplane emergency procedures when this avionic equipment is installed.

## SECTION 4

### NORMAL OPERATION

#### 300 & 400 NAV/COM VOR NAVIGATION CIRCUITS VERIFICATION TEST:

1. Since the TEST position on the 300 and 400 Nav/Com radios is inoperative when the Nav/Coms are coupled to this Area Navigation System, the "VOR SELF TEST OPERATION" as outlined in the 300 and 400 Nav/Com (Types RT-385A and RT-485B) Supplements cannot be used. To check out the complete system, follow the "GROUND CHECK PROCEDURES" as outlined later in this Supplement.

#### VOR/LOC NAVIGATION:

As a convenience to the pilot, a separate supplement (Avionic Operation Guide) is supplied to explain the various procedures for using the VHF Navigation Set for VOR and localizer navigation. Refer to the Avionic Operation Guide for flight procedures.

## AREA NAVIGATION OPERATION NOTES

1. Proper RNAV operation requires valid VOR and DME inputs to the RNAV system. In certain areas, the ground station antenna patterns and transmitter power may be inadequate to provide valid signals to the RNAV. For this reason, intermittent RNAV signal loss may be experienced enroute. Prolonged loss of RNAV signal shall require the pilot to revert to other navigational procedures.
2. As the flight progresses, sequence through waypoints in order, always keep within range of VORTAC being used by maintaining proper altitude and distance from the facility. If usable range is exceeded, the OFF flag will appear on the CDI. Normally, switching waypoints should be done long before flag appearances to ensure the accurate distance, ground speed, time-to-waypoint and minimum crosstrack deviation that will result if closest and strongest signal is used.
3. Selection of the Nav 1, Hold, or Nav 2 positions on the DME Nav mode selector switch electrically eliminates the ANS-351C from the RNAV system, making the computer non-receptive to all incoming data. When operating in these conventional VOR/DME modes, the ANS-351C RADIAL display will spell out "Vor" or "Loc" to prevent being misled into believing that an RNAV waypoint is being flown. Rotating the waypoint selector knob allows preview and set up of waypoints even though operating in the conventional DME modes. Attempting to activate a waypoint in the conventional DME modes by pressing the USE pushbutton will yield no results and the WPT number display will remain blinking, indicating a preview waypoint. Pressing the RTN button will restore the "Vor" or "Loc" annunciation on the RADIAL display and the previously preset waypoints will remain in memory.

### NOTE

The ILS mode selection takes precedence over all other mode selection and is automatic whenever an ILS frequency is selected on the No. 2 navigation receiver.

4. If at anytime an ILS frequency is selected on the No. 2 set, with the ANS-351C operating in the RNAV mode, operation will be restored on the same waypoint when a VOR frequency is again selected. This feature allows channeling through ILS frequencies without changing the selected waypoint number.

5. Ground speed and time-to-waypoint, functions require stabilization time after initial function selection has been made. Allowing 10 minutes for stabilization when operating in the ENR mode will provide a display that is 90 percent of the final calculated value; 12 minutes after initial selection, a display that is 95 percent of the final calculated value will be provided. Stabilization time can be greatly reduced if the APPR mode is selected just prior to, or immediately after, the time that any one of the subject functions is selected. The APPR mode switches in a speed-up circuit that reduces the time for 90 percent of final value display to 4 minutes, and the time for 95 percent of final value display to 5 minutes. After stabilization is achieved, the ENR/APPR control may be switched back to ENR for normal enroute operation.
6. Course changes in excess of 45 degrees will result in temporary display changes for ground speed and time-to-waypoint. Initially, ground speed will decrease and time-to-waypoint will increase after the course change is made. After the new course has been established for several minutes, all functions will again stabilize and display final calculated values. Course changes exceeding 120 degrees require stabilization time greater than 12 minutes in ENR mode or 5 minutes in APPR mode.
7. For accurate CDI sensitivity, approach mode should be restricted to 50 nautical miles or less from the waypoint in use. Enroute mode should be restricted to distances no greater than 200 nautical miles from the waypoint in use.
8. VOR/DME facilities must be co-located.
9. The display of time-to-station/waypoint on the DME display, when in RNAV mode, is only valid if aircraft track is "TO" the waypoint.

## **GROUND CHECK PROCEDURES:**

Before each flight in which RNAV is to be used for primary guidance, the following procedures should be used, when possible, to verify RNAV system performance.

1. Taxi the aircraft to position free and clear of metal structures and within good reception distance of a local VOR/DME facility.

2. **SPEAKER/PHONE Selector Switches** (on audio control panel) -- SET NAV 2 to desired mode.
3. **COM OFF/VOL Control** --TURN ON; adjust NAV VOL control to desired audio level.
4. **NAV Frequency Selection** (on No. 2 Nav Receiver) -- SELECT the local VOR/DME frequency.
5. **DME NAV Mode Selector Switch** -- SELECT RNAV mode.
6. **DME DISPLAY Selector Switch** -- SET to NM.
7. **RNAV Mode Control Knob** -- SELECT APPR (approach) mode.
8. **RADIAL and DISTANCE Selector Knobs** -- SELECT all zeros.
9. **NAV 2 Indicator OBS Knob** -- ROTATE to center the course deviation pointer.
10. **DME DIGITAL DISPLAY** -- NOTE DME distance display readout (after the CDI and Distance displays have stabilized).
11. **RNAV CHK Button** -- PRESS to display raw VOR/DME data. The DME distance-to-VOR readout should agree with the previous (step 10) RNAV DME distance-to-waypoint readout within 0.5 NM.
12. **DME NAV MODE Selector Switch** -- SELECT NAV 2 and observe that the CDI remains within 2 dots of center and check that the DME distance-to VOR display remains within 0.5 NM of the distance displayed in step 10.

## PREVIEWING AND MODIFYING WAYPOINTS:

### NOTES

Modifications to the active waypoint should not be made while the RNAV system is coupled to the autopilot.

Any of the waypoints may be previewed at anytime in any mode:

1. **WPT Selector Knob** -- ROTATE until the desired waypoint number is displayed.
2. **WPT Number Display** -- OBSERVE that number is blinking, indicating that the waypoint is a preview waypoint and not the active waypoint.
3. **RADIAL and DISTANCE Selector Knobs** -- SET as desired if preview waypoint is to be modified.

### NOTE

Only the displayed waypoint, whether it is the active waypoint or a preview waypoint, will be affected by the data (Radial and Distance) selector switches.

4. RTN Pushbutton -- PRESS to return the display to the active waypoint number or operating mode (VOR or LOC).

## NOTE

In the RNAV mode of operation, the waypoint selector may also be manually rotated until the active waypoint number is again displayed in lieu of using the RTN pushbutton.

5. WAYPOINT Number -- OBSERVE that number is continuously on, indicating that active waypoint is now displayed.

## NOTE

Previewing waypoints, whether in the conventional VOR/DME modes or RNAV mode, will not affect system operation in any way.

**WAYPOINT PROGRAMMING ON THE GROUND:**

1. Using a VFR sectional, enroute instrument chart, instrument approach plate, or enroute RNAV chart -- DETERMINE distance and radial for desired waypoints from appropriate VOR/DME stations.

## NOTE

Start engine prior to turning ON avionics equipment.

2. VHF NAV 2 Receiver -- ON to apply power to Nav receiver and RNAV set.
3. DME Nav Mode Selector Switch -- RNAV.
4. WPT Selector Knob -- 1.

## NOTE

When power is first applied to the RNAV set, waypoint number 1 will be displayed above the WPT legend as the active waypoint with zero RADIAL and DISTANCE displayed.

5. RADIAL and DISTANCE Selector Knobs -- ROTATE until the desired data is displayed. The displayed data will be automatically transferred into the number 1 waypoint memory.



6. REPEAT Steps 4 and 5 to program remaining waypoints.

**NOTE**

The displayed waypoint data in the RADIAL and DISTANCE displays before modification is never retained after new waypoint data has been entered. If the active waypoint is revised, the new data will immediately be used in the RNAV computation. Similarly, previewed waypoints, once modified, retain the new data until the waypoint definition is again modified, or the system is turned off.

7. RTN (Return) Pushbutton -- PRESS to display active waypoint.

**CHANGING WAYPOINTS IN FLIGHT:**

1. WPT Selector Knob -- ROTATE until the desired waypoint number and coordinates are displayed.
2. VHF Nav 2 Receiver -- SELECT the desired reference frequency and identify station by listening to ident tone.
3. Nav Indicator OBS Knob -- SET to desired course.
4. USE Pushbutton -- PRESS and observe that the waypoint identification number stops blinking.
5. DME Display Selector Switch -- SELECT desired display readout (Distance-to-waypoint will be displayed when NM position is selected.)

**NOTE**

In the KTS and MIN modes, allow 10-12 minutes to attain a 90-95 percent final (stabilized) calculated value in the ENR mode or 4-5 minutes to attain a 90-95 percent final (stabilized) calculated value in the APPR mode. The NM display is accurate immediately after "lock on".

### **CHECK FUNCTION:**

The distance of the aircraft from the selected VOR/DME station may be checked at anytime while operating in the RNAV mode whenever the DME display selector switch is in the NM position.

1. CHK Pushbutton -- PRESS and HOLD.
2. DME Digital Display -- OBSERVE distance from VOR/DME station displayed.
3. DME WAYPOINT (WPT) Annunciator -- OBSERVE WPT annunciator EXTINGUISHED as a signal that raw DME data is being displayed on the DME.
4. CHK Pushbutton -- RELEASE.

## **SECTION 5**

### **PERFORMANCE**

There is no change to the airplane performance when this avionic equipment is installed. However, the installation of an externally mounted antenna or several related external antennas, will result in a minor reduction in cruise performance.

# SUPPLEMENT

## SSB HF TRANSCEIVER (TYPE ASB-125)

### SECTION 1 GENERAL

The ASB-125 HF transceiver is an airborne, 10-channel, single sideband (SSB) radio with a compatible amplitude modulated (AM) transmitting-receiving system for long range voice communications in the 2 to 18 MHz frequency range. The system consists of a panel mounted receiver/exciter, a remote mounted power amplifier/power supply, an antenna coupler and an externally mounted, fixed wire, medium/high frequency antenna.

A channel selector knob determines the operating frequency of the transceiver which has predetermined crystals installed to provide the desired operating frequencies. A mode selector control is provided to supply the type of emission required for the channel, either sideband, AM or telephone for public correspondence. An audio knob, clarifier knob and squelch knob are provided to assist in audio operation during receive. In addition to the aforementioned controls, which are all located on the receiver/exciter, a meter is incorporated to provide antenna loading readouts.

The system utilizes the airplane microphone, headphone and speaker. Operation and description of the audio control panels used in conjunction with this radio are shown and described in another supplement in this section.

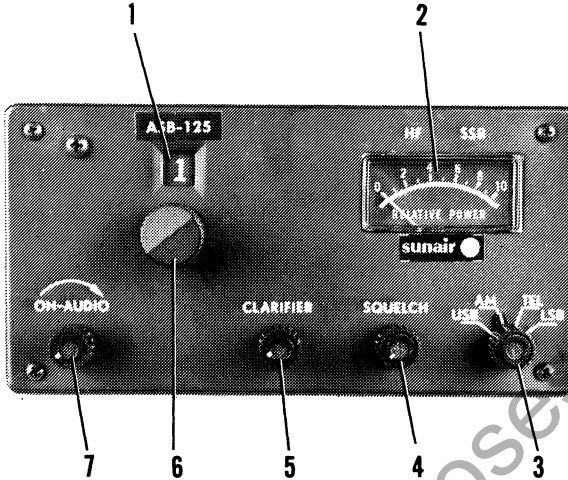

1. CHANNEL WINDOW - Displays selected channel.
2. RELATIVE POWER METER - Indicates relative radiated power of the power amplifier/antenna system.
3. MODE SELECTOR CONTROL - Selects one of the desired operating modes:
  - USB - Selects upper sideband operation for long range voice communications.
  - AM - Selects compatible AM operation and full AM reception.
  - TEL - Selects upper sideband with reduced carrier, used for public correspondence telephone and ship-to-shore.
  - LSB - (Optional) Selects lower sideband operation (not legal in U.S., Canada and most other countries).
4. SQUELCH CONTROL - Used to adjust signal threshold necessary to activate receiver audio. Clockwise rotation increases background noise (decreases squelch action); counterclockwise rotation decreases background noise.
5. CLARIFIER CONTROL - Used to "clarify" single sideband speech during receive while in USB mode only.
6. CHANNEL SELECTOR CONTROL - Selects desired channel. Also selects AM mode if channel frequency is 2003 kHz, 2182 kHz or 2638 kHz.
7. ON - AUDIO CONTROL - Turns set ON and controls receiver audio gain.

Figure 1. SSB HF Transceiver Operating Controls

## SECTION 2 LIMITATIONS

There is no change to the airplane limitations when this avionic equipment is installed.

## SECTION 3 EMERGENCY PROCEDURES

There is no change to the airplane emergency procedures when this avionic equipment is installed.

## SECTION 4 NORMAL PROCEDURES

### COMMUNICATIONS TRANSCEIVER OPERATION:

#### NOTE

The pilot should be aware of the two following radio operational restrictions:

- a. For sideband operation in the United States, Canada and various other countries, only the upper sideband may be used. Use of lower sideband is prohibited.
- b. Only AM transmissions are permitted on frequencies 2003 kHz, 2182 kHz and 2638 kHz. The selection of these channels will automatically select the AM mode of transmission.

1. XMTR SEL Switch (on audio control panel) -- SELECT transceiver.
2. SPEAKER/PHONE Selector Switches (on audio control panel) -- SELECT desired mode.
3. ON-AUDIO Control -- ON (allow equipment to warm up for 5 minutes for sideband or one minute for AM operation and adjust audio to comfortable listening level).
4. Channel Selector Control -- SELECT desired frequency.
5. Mode Selector Control -- SELECT operating mode.

6. SQUELCH Control -- ADJUST clockwise for normal background noise output, then slowly adjust counterclockwise until the receiver is silent.
7. CLARIFIER Control -- ADJUST when upper single sideband RF signal is being received for maximum clarity.
8. Mike Button:
  - a. To Transmit -- DEPRESS and SPEAK into microphone.

## NOTE

Sidetone and interphone intercom are not available on this radio.

- b. To Receive -- RELEASE mike button.

## NOTE

Voice communications are not available in the LSB mode.

## NOTE

Lower sideband (LSB) mode is not legal in the U.S., Canada, and most other countries.

## SECTION 5

### PERFORMANCE

There is no change to the airplane performance when this avionic equipment is installed. However, the installation of an externally mounted antenna or several related external antennas, will result in a minor reduction in cruise performance.

## SUPPLEMENT

# CESSNA NAVOMATIC 200A AUTOPILOT (Type AF-295B)

## SECTION 1 GENERAL

The Cessna 200A Navomatic is an all electric, single-axis (aileron control) autopilot system that provides added lateral and directional stability. Components are a computer-amplifier, a turn coordinator, an aileron actuator, and a course deviation indicator(s) incorporating a localizer reversed (BC) indicator light.

Roll and yaw motions of the airplane are sensed by the turn coordinator gyro. The computer-amplifier electronically computes the necessary correction and signals the actuator to move the ailerons to maintain the airplane in the commanded lateral attitude.

The actuator includes a thermostatic switch which monitors the operating temperature of the motor. If the temperature becomes abnormal, the thermostatic switch opens and disengages the autopilot to remove power from the actuator. After approximately 10 minutes, the switch will automatically close to reapply power to the actuator and autopilot system.

The 200A Navomatic will also capture and track a VOR or localizer course using signals from a VHF navigation receiver.

The operating controls for the Cessna 200A Navomatic are located on the front panel of the computer-amplifier, shown in Figure 1. The primary function pushbuttons (DIR HOLD, NAV CAPT, and NAV TRK), are interlocked so that only one function can be selected at a time. The HI SENS and BACK CRS pushbuttons are not interlocked so that either or both of these functions can be selected at any time.

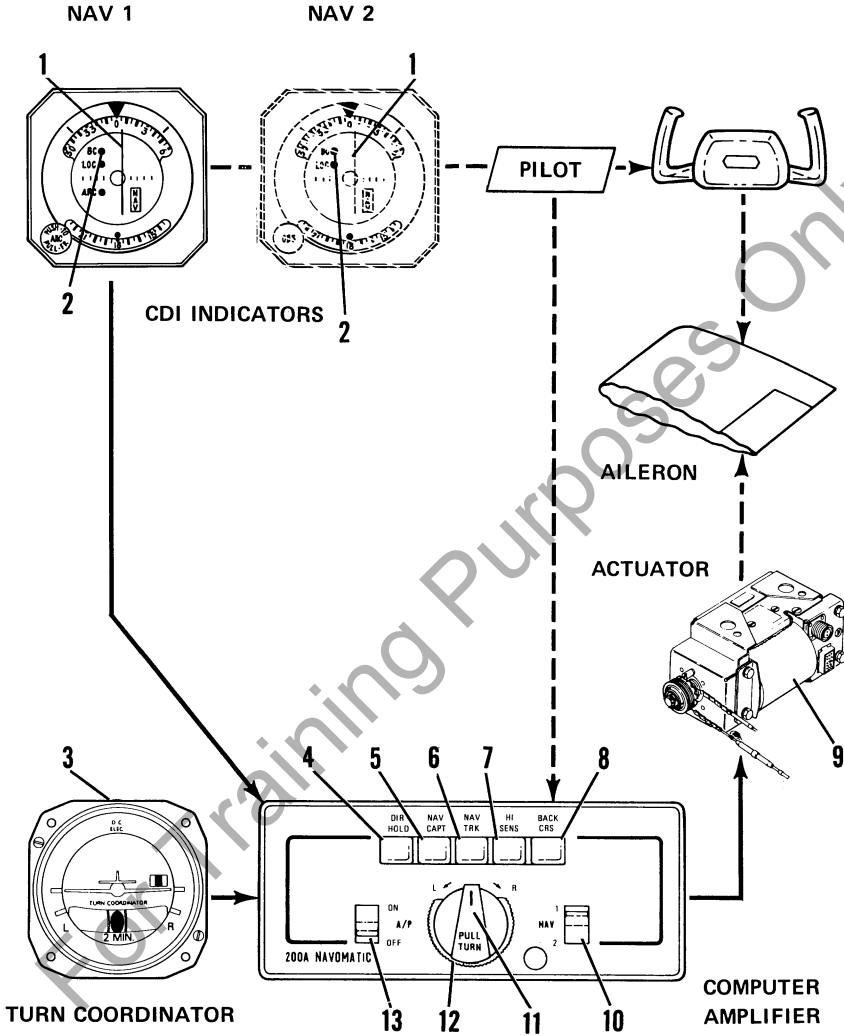

Figure 1. Cessna 200A Autopilot, Operating Controls and Indicators  
(Sheet 1 of 2)



1. COURSE DEVIATION INDICATOR - Provides VOR/LOC navigation inputs to autopilot for intercept and tracking modes.
2. LOCALIZER REVERSED INDICATOR LIGHT - Amber light, labeled BC, illuminates when BACK CRS button is pushed in (engaged) and LOC frequency selected. BC light indicates course indicator needle is reversed on selected receiver (when turned to a localizer frequency). This light is located within the CDI indicator.
3. TURN COORDINATOR - Senses roll and yaw for wings leveling and command turn functions.
4. DIR HOLD PUSHBUTTON - Selects direction hold mode. Airplane holds direction it is flying at time button is pushed.
5. NAV CAPT PUSHBUTTON - Selects NAV capture mode. When parallel to desired course, the airplane will turn to a pre-described intercept angle and capture selected VOR or LOC course.
6. NAV TRK PUSHBUTTON - Selects NAV track mode. Airplane tracks selected VOR or LOC course.
7. HI SENS PUSHBUTTON - During NAV CAPT or NAV TRK operation, this high sensitivity setting increases autopilot response to NAV signal to provide more precise operation during localizer approach. In low sensitivity position (pushbutton out), response to NAV signal is dampened for smoother tracking of enroute VOR radials; it also smooths out effect of course scalloping during NAV operation.
8. BACK CRS PUSHBUTTON - Used with LOC operation only. With A/P switch OFF or ON, and when navigation receiver selected by NAV switch is set to a localizer frequency, it reverses normal localizer needle indication (CDI) and causes localizer reversed (BC) light to illuminate. With A/P switch ON, reverses localizer signal to autopilot.
9. ACTUATOR - The torque motor in the actuator causes the ailerons to move in the commanded direction.
10. NAV SWITCH - Selects NAV 1 or NAV 2 navigation receiver.
11. PULL TURN KNOB - When pulled out and centered in detent, airplane will fly wings-level; when turned to the right (R), the airplane will execute a right, standard rate turn; when turned to the left (L), the airplane will execute a left, standard rate turn. When centered in detent and pushed in, the operating mode selected by a pushbutton is engaged.
12. TRIM - Used to trim autopilot to compensate for minor variations in aircraft trim or weight distribution. (For proper operation, the aircraft's rudder trim must be manually trimmed before the autopilot is engaged).
13. A/P SWITCH - Turns autopilot ON or OFF.

Figure 1. Cessna 200A Autopilot, Operating Controls and Indicators  
(Sheet 2 of 2)

## SECTION 2

### LIMITATIONS

The following autopilot limitation must be followed during airplane operation:

1. Autopilot must be OFF for takeoff and landing.

OPERATING LIMITATION WITH AUTOPILOT ENGAGED:

1. Maximum Airspeed -- 155 KIAS.

## SECTION 3

### EMERGENCY PROCEDURES

TO OVERRIDE THE AUTOPILOT:

1. Airplane Control Wheel -- ROTATE as required to override auto-pilot.

#### NOTE

The servo may be overpowered at anytime without damage.

TO TURN OFF AUTOPILOT:

1. A/P ON-OFF Switch -- OFF.

TURN COORDINATOR FAILURE:

1. A/P ON-OFF Switch -- OFF.

## SECTION 4

### NORMAL PROCEDURES

#### NOTE

If autopilot is to be turned on while airplane is on the ground, the control wheel should be held to prevent ailerons from banging stops and possibly damaging, or shearing, actuator shear pins.

#### BEFORE TAKE-OFF AND LANDING:

1. A/P ON-OFF Switch -- OFF.
2. BACK CRS Button -- OFF (see Caution note under Nav Capture).

#### NOTE

Periodically verify operation of amber warning light(s), labeled BC on CDI(s), by engaging BACK CRS button with a LOC frequency selected.

#### INFLIGHT WINGS LEVELING:

1. Airplane Rudder Trim -- ADJUST for zero slip ("Ball" centered on Turn Coordinator).
2. PULL-TURN Knob -- PULL out and CENTER.
3. A/P ON-OFF Switch -- ON.
4. Autopilot TRIM Control -- ADJUST for zero turn rate (wings level indication on Turn Coordinator).

#### COMMAND TURNS:

1. PULL-TURN Knob -- PULL out and ROTATE.

#### DIRECTION HOLD:

1. PULL-TURN Knob -- PULL out and CENTER.
2. Autopilot TRIM Control -- ADJUST for zero turn rate.
3. Airplane Rudder Trim -- ADJUST for zero slip ("Ball" centered).
4. DIR HOLD Button -- PUSH.
5. PULL-TURN Knob -- PUSH in detent position when airplane is on desired heading.
6. Autopilot TRIM Control -- READJUST for zero turn rate.

## NAV CAPTURE (VOR/LOC):

1. PULL-TURN Knob -- PULL out and CENTER.
2. NAV 1-2 Selector Switch -- SELECT desired VOR receiver.
3. Nav Receiver OBS or ARC Knob -- SET desired VOR course (if tracking omni).

## NOTE

Optional ARC knob should be in center position and ARC amber warning light should be off.

4. NAV CAPT Button -- PUSH.
5. HI SENS Button -- PUSH for localizer and "close-in" omni intercepts.
6. BACK CRS Button -- PUSH only if intercepting localizer front course outbound or back course inbound.

**CAUTION**

With BACK CRS button pushed in and localizer frequency selected, the CDI on selected nav radio will be reversed even when the autopilot switch is OFF.

7. PULL-TURN Knob -- Turn airplane parallel to desired course.

## NOTE

Airplane must be turned until heading is within  $\pm 5^\circ$  of desired course.

8. PULL TURN Knob -- CENTER and PUSH in. The airplane should then turn toward desired course at  $45^\circ \pm 10^\circ$  intercept angle (if the CDI needle is in full deflection).

## NOTE

If more than 15 miles from the station or more than 3 minutes from intercept, use a manual intercept procedure.

NAV TRACKING (VOR/LOC):

1. NAV TRK Button -- PUSH when CDI centers and airplane is within  $\pm 5^\circ$  of course heading.
2. HI SENS BUTTON -- DISENGAGE for enroute omni tracking (leave ENGAGED for localizer).
3. Autopilot TRIM Control -- READJUST as required to maintain track.

NOTE

Optional ARC function, if installed, should not be used for autopilot operation. If airplane should deviate off course, pull out PULL TURN knob and readjust airplane rudder trim for straight flight on the turn coordinator. Push in PULL TURN knob to reintercept course. If deviation persists, progressively make slight adjustments of autopilot TRIM control or heading bug on the directional gyro, towards the course as required to maintain track.

## SECTION 5 PERFORMANCE

There is no change to the airplane performance when this avionic equipment is installed.

For Training Purposes Only

# **SUPPLEMENT**

## **CESSNA 300 ADF**

### **(Type R-546E)**

#### **SECTION 1**

#### **GENERAL**

The Cessna 300 ADF is a panel-mounted, digitally tuned automatic direction finder. It is designed to provide continuous 1 kHz digital tuning in the frequency range of 200 kHz to 1,699 kHz and eliminates the need for mechanical band switching. The system is comprised of a receiver, a bearing indicator, a loop antenna, and a sense antenna. Operating controls and displays for the Cessna 300 ADF are shown and described in Figure 1. The audio systems used in conjunction with this radio for speaker-phone selection are shown and described in another supplement in this section.

The Cessna 300 ADF can be used for position plotting and homing procedures, and for aural reception of amplitude-modulated (AM) signals.

With the function selector knob at ADF, the Cessna 300 ADF provides a visual indication, on the bearing indicator, of the bearing to the transmitting station relative to the nose of the airplane. This is done by combining signals from the sense antenna with signals from the loop antenna.

With the function selector knob at REC, the Cessna 300 ADF uses only the sense antenna and operates as a conventional low-frequency receiver.

The Cessna 300 ADF is designed to receive transmission from the following radio facilities: commercial AM broadcast stations, low-frequency range stations, non-directional radio beacons, ILS compass locators.

#### **SECTION 2**

#### **LIMITATIONS**

There is no change to the airplane limitations when this avionics equipment is installed.

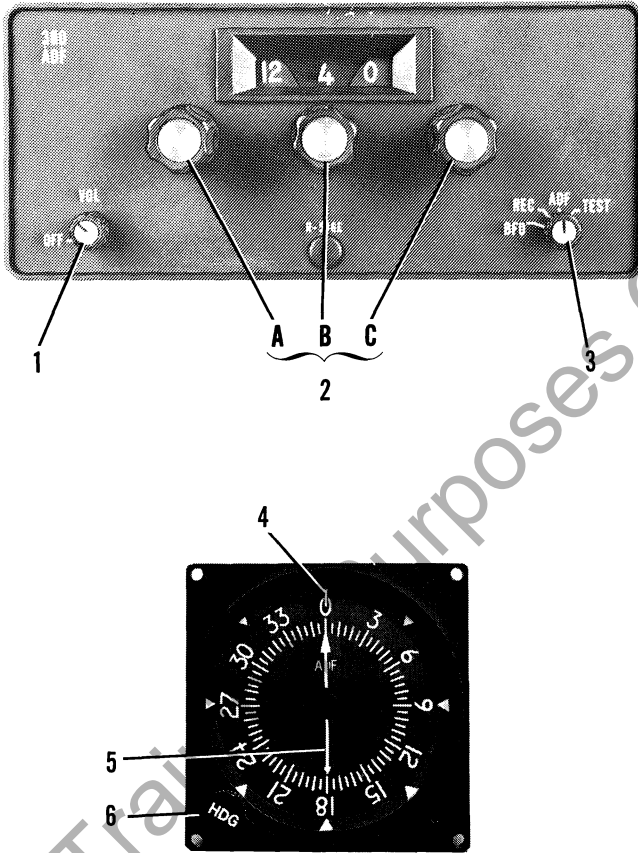

1. OFF/VOL CONTROL - Controls primary power and audio output level. Clockwise rotation from OFF position applies primary power to receiver; further clockwise rotation increases audio level.
2. FREQUENCY SELECTORS - Knob (A) selects 100-kHz increments of receiver frequency, knob (B) selects 10-kHz increments, and knob (C) selects 1 kHz increments.

Figure 1. Cessna 300 ADF Operating Controls and Indicators (Sheet 1 of 2)



3. FUNCTION SWITCH:

**BFO:** Selects operation as communication receiver using only sense antenna and activates 1000-Hz tone beat frequency oscillator to permit coded identifier of stations transmitting keyed CW signals (Morse Code) to be heard.

**REC:** Selects operation as standard communication receiver using only sense antenna.

**ADF:** Set operates as automatic direction finder using loop and sense antennas.

**TEST:** Momentary-on position used during ADF operation to test bearing reliability. When held in TEST position, slews indicator pointer clockwise; when released, if bearing is reliable, pointer returns to original bearing position.

4. **INDEX (ROTATABLE CARD)** - Indicates magnetic or true heading of aircraft, as selected by HDG control or may be set to 0° for relative bearing determinations.
5. **POINTER** - Indicates station bearing in degrees of azimuth, relative to the nose of the aircraft. When heading control is adjusted, indicates magnetic or true bearing of radio signal.
6. **HEADING CARD CONTROL (HDG)** - Rotates card to set in relative, magnetic, or true bearing references.

Figure 1. Cessna 300 ADF Operating Controls and Indicators (Sheet 2 of 2)

## SECTION 3

### EMERGENCY PROCEDURES

There is no change to the airplane emergency procedures when this avionic equipment is installed.

## SECTION 4

### NORMAL PROCEDURES

TO OPERATE AS A COMMUNICATIONS RECEIVER ONLY:

1. OFF/VOL Control -- ON.
2. Function Selector Knob -- REC.
3. Frequency Selector Knobs -- SELECT operating frequency.
4. ADF SPEAKER/PHONE Selector Switch (on audio control panel) -- SELECT speaker or phone position as desired.
5. VOL Control -- ADJUST to desired listening level.

TO OPERATE AS AN AUTOMATIC DIRECTION FINDER:

1. OFF/VOL Control -- ON.
2. Frequency Selector Knobs -- SELECT operating frequency.
3. ADF SPEAKER/PHONE Selector Switch (on audio control panel) -- SELECT AS DESIRED.
4. Function Selector Knob -- ADF position and note relative bearing on indicator.

TO TEST RELIABILITY OF AUTOMATIC DIRECTION FINDER:

1. Function Selector Knob -- ADF position and note relative bearing on indicator.
2. Function Selector Knob -- TEST position and observe that pointer moves away from relative bearing at least 10 to 20 degrees.
3. Function Selector Knob -- ADF position and observe that pointer returns to same relative bearing as in step (1).

TO OPERATE BFO:

1. OFF/VOL Control -- ON.
2. Function Selector Knob -- BFO.
3. Frequency Selector Knobs -- SELECT operating frequency.
4. ADF SPEAKER/PHONE Selector Switch (on audio control panel) -- SELECT speaker or phone position.
5. VOL Control -- ADJUST to desired listening level.

NOTE

A 1000-Hz tone is heard in the audio output when a CW signal (Morse Code) is tuned in properly.

## SECTION 5

### PERFORMANCE

There is no change to the airplane performance when this avionic equipment is installed. However, the installation of an externally mounted antenna or related external antennas, will result in a minor reduction in cruise performance.

For Training Purposes Only

## SUPPLEMENT

# CESSNA 300 NAV/COM (720-Channel - Type RT-385A)

## SECTION 1 GENERAL

The Cessna 300 Nav/Com (Type RT-385A), shown in figure 1, consists of a panel-mounted receiver-transmitter and a single or dual-pointer remote course deviation indicator.

The set includes a 720-channel VHF communications receiver-transmitter and a 200-channel VHF navigation receiver, both of which may be operated simultaneously. The communications receiver-transmitter receives and transmits signals between 118.000 and 135.975 MHz in 25-kHz steps. The navigation receiver receives omni and localizer signals between 108.00 and 117.95 MHz in 50-kHz steps. The circuits required to interpret the omni and localizer signals are located in the course deviation indicator. Both the communications and navigation operating frequencies are digitally displayed by incandescent readouts on the front panel of the Nav/Com.

A DME receiver-transmitter or a glide slope receiver, or both, may be interconnected with the Nav/Com set for automatic selection of the associated DME or glide slope frequency. When a VOR frequency is selected on the Nav/Com, associated VORTAC or VOR-DME station frequency will also be selected automatically; likewise, if a localizer frequency is selected, the associated glide slope will be selected automatically.

The course deviation indicator includes either a rectilinear single-pointer and related NAV flag for VOR/LOC indication only, or rectilinear dual pointers and related NAV and GS flags for both VOR/LOC and glide slope indications. Both types of course deviation indicators incorporate an amber back-course lamp (BC) which lights when optional back course (reversed sense) operation is selected and a green localizer lamp (LOC) which illuminates when a localizer frequency is selected on the associated Navigation Receiver. Both types may be provided with Automatic Radial Centering which, depending on how it is selected, will automatically indicate the bearing TO or FROM the VOR station. The ARC feature includes an amber annunciator light that illuminates when ARC is in use.

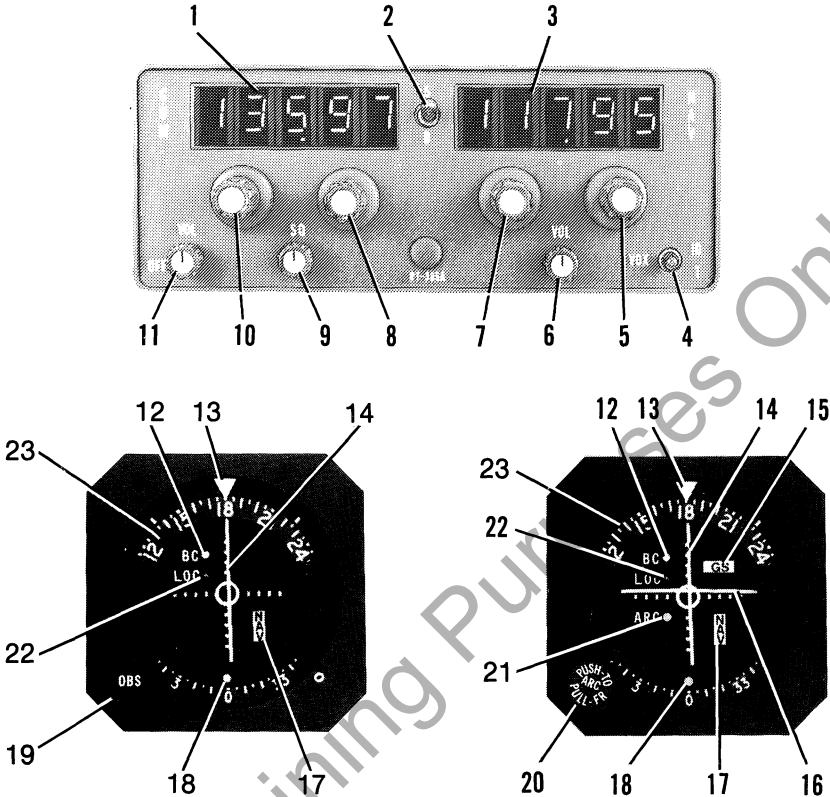

1. COMMUNICATION OPERATING FREQUENCY READOUT (Third-decimal-place is shown by the position of the "5-0" switch).
2. 5-0 SWITCH - Part of Com Receiver-Transmitter Fractional MHz Frequency Selector. In "5" position, enables Com frequency readout to display and Com Fractional MHz Selector to select frequency in .05-MHz steps between .025 and .975 MHz. In "0" position, enables COM frequency readout to display and Com Fractional MHz Selector to select frequency in .05-MHz steps between 000 and .950 MHz.

NOTE

The "5" or "0" may be read as the third decimal digit, which is not displayed in the Com fractional frequency display.

Figure 1. Cessna 300 Nav/Com (Type RT-385A), Operating Controls and Indicators (Sheet 1 of 3)

3. NAVIGATION OPERATING FREQUENCY READOUT.
4. ID-VOX-T SWITCH - With VOR or LOC station selected, in ID position, station identifier signal is audible; in VOX (Voice) position, identifier signal is suppressed; in T (Momentary On) position, the VOR navigational self-test function is selected.
5. NAVIGATION RECEIVER FRACTIONAL MEGAHERTZ SELECTOR - Selects Nav frequency in .05-MHz steps between .00 and .95 MHz; simultaneously selects paired glide slope frequency and DME channel.
6. NAV VOL CONTROL - Adjusts volume of navigation receiver audio.
7. NAVIGATION RECEIVER MEGAHERTZ SELECTOR - Selects NAV frequency in 1-MHz steps between 108 and 117 MHz; simultaneously selects paired glide slope frequency and DME channel.
8. COMMUNICATION RECEIVER-TRANSMITTER FRACTIONAL MEGAHERTZ SELECTOR - Depending on position of 5-0 switch, selects COM frequency in .05-MHz steps between .000 and .975 MHz. The 5-0 switch identifies the last digit as either 5 or 0.
9. SQUELCH CONTROL - Used to adjust signal threshold necessary to activate COM receiver audio. Clockwise rotation increases background noise (decreases squelch action); counterclockwise rotation decreases background noise.
10. COMMUNICATION RECEIVER-TRANSMITTER MEGAHERTZ SELECTOR - Selects COM frequency in 1-MHz steps between 118 and 135 MHz.
11. COM OFF-VOL CONTROL - Combination on/off switch and volume control; turns on NAV/COM set and controls volume of communications receiver audio.
12. BC LAMP - Amber light illuminates when an autopilot's back-course (reverse sense) function is engaged; indicates course deviation pointer is reversed on selected receiver when tuned to a localizer frequency. Light dimming is only available when installed with an audio control panel incorporating the annunciator lights DAY/NITE selector switch.
13. COURSE INDEX - Indicates selected VOR course.
14. COURSE DEVIATION POINTER - The rectilinear vertical pointer indicates course deviation from selected omni course or localizer centerline. When power is removed or the received signal applied to the indicator is not usable, the vertical pointer is stored out of view to the right of the indicator.
15. GLIDE SLOPE "GS" FLAG - When visible, red GS flag indicates unreliable glide slope signal or improperly operating equipment. Flag disappears when a reliable glide slope signal is being received.
16. GLIDE SLOPE DEVIATION POINTER - The rectilinear horizontal pointer indicates deviation from ILS glide slope. When power is removed or the received signal applied to the indicator is not usable, the horizontal pointer is stored out of view to the top of the indicator.

Figure 1. Cessna 300 Nav/Com (Type RT-385A), Operating Controls and Indicators (Sheet 2 of 3)

17. NAV/TO-FROM INDICATOR - Operates only with a VOR or localizer signal. Red NAV position (Flag) indicates unusable signal. With usable VOR signal, indicates whether selected course is TO or FROM station. With usable localizer signal, shows TO.
18. RECIPROCAL COURSE INDEX - Indicates reciprocal of selected VOR course.
19. OMNI BEARING SELECTOR (OBS) - Rotates OBS course card to select desired course.
20. AUTOMATIC RADIAL CENTERING (ARC-PUSH-TO/PULL-FR) SELECTOR - In center detent, functions as conventional OBS. Pushed to inner (Momentary On) position, turns OBS course card to center course deviation pointer with a TO flag, then returns to conventional OBS selection. Pulled to outer detent, continuously drives OBS course card to indicate bearing from VOR station, keeping course deviation pointer centered, with a FROM flag. ARC function will not operate on localizer frequencies.
21. AUTOMATIC RADIAL CENTERING (ARC) LAMP - Amber light illuminates when Automatic Radial Centering is in use. Light dimming is only available when installed with an audio control panel incorporating the annunciator lights DAY/NITE selector switch.
22. LOCALIZER (LOC) LAMP - Green light illuminates when a localizer frequency is selected on the associated Navigation Receiver. Light dimming is only available when installed with an audio control panel incorporating the annunciator light DAY/NITE selector switch.
23. OBS COURSE CARD - Indicates selected VOR course under course index.

Figure 1. Cessna 300 Nav/Com (Type RT-385A), Operating Controls and Indicators (Sheet 3 of 3)



The Cessna 300 Nav/Com incorporates a variable threshold automatic squelch. With this squelch system, you set the threshold level for automatic operation - the further clockwise the lower the threshold - or the more sensitive the set. When the signal is above this level, it is heard even if the noise is very close to the signal. Below this level, the squelch is fully automatic so when the background noise is very low, very weak signals (that are above the noise) are let through. For normal operation of the squelch circuit, just turn the squelch clockwise until noise is heard - then back off slightly until it is quiet, and you will have automatic squelch with the lowest practical threshold. This adjustment should be rechecked periodically during each flight to assure optimum reception.

All controls for the Nav/Com, except the standard omni bearing selector (OBS) knob or the optional automatic radial centering (ARC) knob located on the course deviation indicator, are mounted on the front panel of the receiver-transmitter. Operation and description of the audio control panels used in conjunction with this radio are shown and described in another supplement in this section.

## SECTION 2 LIMITATIONS

There is no change to the airplane limitations when this avionic equipment is installed.

## SECTION 3 EMERGENCY PROCEDURES

There is no change to the airplane emergency procedures when this avionic equipment is installed. However, if the frequency readouts fail, the radio will remain operational on the last frequency selected. The frequency control should not be moved due to the difficulty of obtaining a known frequency under this condition.

## SECTION 4

### NORMAL PROCEDURES

#### COMMUNICATION RECEIVER-TRANSMITTER OPERATION:

1. COM OFF/VOL Control -- TURN ON; adjust to desired audio level.
2. XMTR SEL Switch (on audio control panel) -- SET to desired Nav/Com Radio.
3. SPEAKER/PHONE Selector Switches (on audio control panel) -- SET to desired mode.
4. 5-0 Fractional MHz Selector Switch -- SELECT desired operating frequency (does not affect navigation frequencies).
5. COM Frequency Selector Switch -- SELECT desired operating frequency.
6. SQ Control -- ROTATE counterclockwise to just eliminate background noise. Adjustment should be checked periodically to assure optimum reception.
7. Mike Button:
  - a. To Transmit -- DEPRESS and SPEAK into microphone.

#### NOTE

Sidetone may be selected by placing the AUTO selector switch (on audio control panel) in either the SPEAKER or PHONE position. Sidetone may be eliminated by placing the AUTO selector switch in the OFF position. Adjustment of sidetone on audio control panels supplied with three transmitters cannot be accomplished externally. However, audio control panels supplied with one or two transmitters have sidetone adjustment pots that are accessible through the front of the audio control panel with a small screwdriver.

- b. To Receive -- RELEASE mike button.

#### NAVIGATION OPERATION:

#### NOTE

The pilot should be aware that on Cessna airplanes equipped with the vertical fin mounted combination glide slope and omni antenna, pilots should avoid use of  $2700 \pm 100$  RPM on airplanes equipped with a two-bladed propeller or  $1800 \pm 100$  RPM on airplanes equipped with a three-bladed propeller during ILS approaches to avoid any possibility of oscillations of the glide slope deviation pointer caused by propeller interference.

1. COM OFF/VOL Control -- TURN ON.
2. SPEAKER/PHONE Selector Switches (on audio control panel) -- SET to desired mode.
3. NAV Frequency Selector Knobs -- SELECT desired operating frequency.

NOTE

If a localizer frequency was selected, the LOC lamp will illuminate green.

4. NAV VOL -- ADJUST to desired audio level.
5. ID-VOX-T Switch:
  - a. To Identify Station -- SET to ID to hear navigation station identifier signal.
  - b. To Filter Out Station Identifier Signal -- SET to VOX to include filter in audio circuit.
6. Course Deviation Indicator -- CHECK that it reads TO or FROM with the usable VOR navigation signal and that the vertical pointer is indicating the bearing to the VOR station.
7. ARC PUSH-TO/PULL-FROM Knob (If Applicable):
  - a. To Use As Conventional OBS -- PLACE in center detent and select desired course.
  - b. To Obtain Bearing TO VOR Station -- PUSH (ARC/PUSH-TO) knob to inner (momentary on) position.

NOTE

ARC lamp will illuminate amber while the OBS course card is moving to center with the course deviation pointer. After alignment has been achieved to reflect bearing to VOR, automatic radial centering will automatically shut down, causing the ARC lamp to go out.

- c. To Obtain Continuous Bearing FROM VOR Station -- PULL (ARC/PULL-FR) knob to outer detent.

NOTE

ARC lamp will illuminate amber, OBS course card will turn to center the course deviation pointer with a FROM flag to indicate bearing from VOR station.

8. OBS Knob (If Applicable) -- SELECT desired course.

## VOR SELF-TEST OPERATION:

1. COM OFF/VOL Control -- TURN ON.
2. NAV Frequency Selector Switches -- SELECT usable VOR station signal.
3. OBS Knob -- SET for 0° course at course index; course deviation pointer centers or deflects left or right, depending on bearing of signal; NAV/TO-FROM indicator shows TO or FROM.
4. ID/VOX/T Switch -- PRESS to T and HOLD at T; course deviation pointer centers and NAV/TO-FROM indicator shows FROM.
5. OBS Knob -- TURN to displace course approximately 10° to either side of 0° (while holding ID/VOX/T to T). Course deviation pointer deflects full scale in direction corresponding to course displacement. NAV/TO-FROM indicator shows FROM.

## NOTE

When the 300 NAV/COM is coupled to the ANS-351C RNAV system the TEST operation is non-functional. Refer to the "Ground Check Procedures" in the Area Navigation System (Type ANS-351C) Supplement in this section to verify VOR operation of the CDI.

6. ID/VOX/T Switch -- RELEASE for normal operation.

## NOTE

This test does not fulfill the requirements of FAR 91.25.

## SECTION 5

### PERFORMANCE

There is no change to the airplane performance when this avionic equipment is installed. However, the installation of an externally mounted antenna or several related external antennas, will result in a minor reduction in cruise performance.

**SUPPLEMENT**  
**CESSNA 300 TRANSPONDER**  
**(Type RT-359A)**  
**AND**  
**OPTIONAL ALTITUDE ENCODER (BLIND)**

**SECTION 1**  
**GENERAL**

The Cessna 300 Transponder (Type RT-359A), shown in Figure 1, is the airborne component of an Air Traffic Control Radar Beacon System (ATCRBS). The transponder enables the ATC ground controller to "see" and identify the aircraft, while in flight, on the control center's radarscope more readily.

The Cessna 300 Transponder system consists of a panel-mounted unit and an externally-mounted antenna. The transponder receives interrogating pulse signals on 1030 MHz and transmits pulse-train reply signals on 1090 MHz. The transponder is capable of replying to Mode A (aircraft identification) and also to Mode C (altitude reporting) when coupled to an optional altitude encoder system. The transponder is capable of replying on both modes of interrogation on a selective reply basis on any of 4096 information code selections. The optional altitude encoder system (not part of a standard 300 Transponder system) required for Mode C (altitude reporting) operation consists of a completely independent remote-mounted digitizer that is connected to the static system and supplies encoded altitude information to the transponder. When the altitude encoder system is coupled to the 300 Transponder system, altitude reporting information is available in 100-foot increments.

All Cessna 300 Transponder operating controls are located on the front panel of the unit. Functions of the operating controls are described in Figure 1.

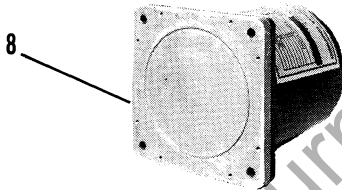
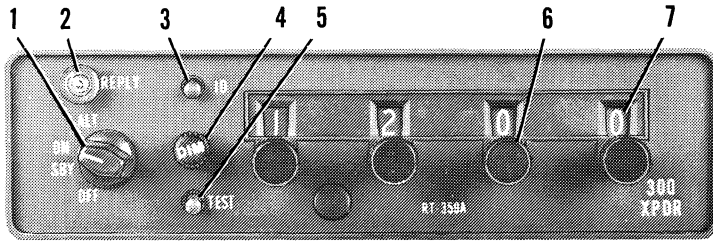

1. **FUNCTION SELECTOR SWITCH** - Controls application of power and selects transponder operating mode as follows:
  - OFF - Turns set off.
  - SBY - Turns set on for equipment warm-up or standby power.
  - ON - Turns set on and enables transponder to transmit Mode A (aircraft identification) reply pulses.
  - ALT - Turns set on and enables transponder to transmit both Mode A (aircraft identification) reply pulses and Mode C (altitude reporting) pulses selected automatically by the interrogating signal.
2. **REPLY LAMP** - Lamp flashes to indicate transmission of reply pulses; glows steadily to indicate transmission of IDENT pulse or satisfactory self-test operation. (Reply lamp will also glow steadily during initial warm-up period.)

Figure 1. Cessna 300 Transponder and Altitude Encoder (Blind)  
(Sheet 1 of 2)

PILOT'S OPERATING HANDBOOK      CESSNA 300 TRANSPONDER  
SUPPLEMENT                              AND ALTITUDE ENCODER (BLIND)

3. IDENT (ID) SWITCH - When depressed, selects special pulse identifier to be transmitted with transponder reply to effect immediate identification of aircraft on ground controller's display. (Reply lamp will glow steadily during duration of IDENT pulse transmission.)
4. DIMMER (DIM) CONTROL - Allows pilot to control brilliance of reply lamp.
5. SELF-TEST (TST) SWITCH - When depressed, causes transponder to generate a self-interrogating signal to provide a check of transponder operation. (Reply lamp will glow steadily to verify self-test operation.)
6. REPLY-CODE SELECTOR KNOBS (4) - Select assigned Mode A reply code.
7. REPLY-CODE INDICATORS (4) - Display selected Mode A reply code.
8. REMOTE-MOUNTED DIGITIZER - Provides an altitude reporting code range from -1000 feet up to the airplane's maximum service ceiling.

Figure 1. Cessna 300 Transponder and Altitude Encoder (Blind)  
(Sheet 2 of 2)

## **SECTION 2 LIMITATIONS**

There is no change to the airplane limitations when this avionic equipment is installed. However, the following information must be displayed in the form of a placard located near the altimeter.

ALTITUDE ENCODER EQUIPPED

## **SECTION 3 EMERGENCY PROCEDURES**

TO TRANSMIT AN EMERGENCY SIGNAL:

1. Function Selector Switch -- ON.
2. Reply-Code Selector Knobs -- SELECT 7700 operating code.

TO TRANSMIT A SIGNAL REPRESENTING LOSS OF ALL COMMUNICATIONS (WHEN IN A CONTROLLED ENVIRONMENT):

1. Function Selector Switch -- ON.
2. Reply-Code Selector Knobs -- SELECT 7700 operating code for 1 minute; then SELECT 7600 operating code for 15 minutes and then REPEAT this procedure at same intervals for remainder of flight.

## **SECTION 4 NORMAL PROCEDURES**

BEFORE TAKEOFF:

1. Function Selector Switch -- SBY.

TO TRANSMIT MODE A (AIRCRAFT IDENTIFICATION) CODES IN FLIGHT:

1. Reply-Code Selector Knobs -- SELECT assigned code.



2. Function Selector Switch -- ON.
3. DIM Control -- ADJUST light brilliance of reply lamp.

## NOTE

During normal operation with function selector switch in ON position, reply lamp flashes indicating transponder replies to interrogations.

4. ID Button -- DEPRESS momentarily when instructed by ground controller to "squawk IDENT" (reply lamp will glow steadily, indicating IDENT operation).

## TO TRANSMIT MODE C (ALTITUDE REPORTING) CODES IN FLIGHT:

1. Reply-Code Selector Knobs -- SELECT assigned code.
2. Function Selector Switch -- ALT.

## NOTE

When directed by ground controller to "stop altitude squawk", turn Function Selector Switch to ON for Mode A operation only.

## NOTE

Pressure altitude is transmitted by the transponder for altitude squawk and conversion to indicated altitude is done in ATC computers. Altitude squawked will only agree with indicated altitude when the local altimeter setting in use by the ground controller is set in the aircraft altimeter.

3. DIM Control -- ADJUST light brilliance of reply lamp.

## TO SELF-TEST TRANSPONDER OPERATION:

1. Function Selector Switch -- SBY and wait 30 seconds for equipment to warm-up.
2. Function Selector Switch -- ON or ALT.
3. TST Button -- DEPRESS (reply lamp should light brightly regardless of DIM control setting).
4. TST Button -- RELEASE for normal operation.

## **SECTION 5**

### **PERFORMANCE**

There is no change to the airplane performance when this avionic equipment is installed. However, the installation of an externally mounted antenna or several related external antennas, will result in a minor reduction in cruise performance.

For Training Purposes Only

## SUPPLEMENT

# CESSNA 300 TRANSPONDER (Type RT-359A) AND OPTIONAL ENCODING ALTIMETER (Type EA-401A)

## SECTION 1 GENERAL

The Cessna 300 Transponder (Type RT-359A), shown in Figure 1, is the airborne component of an Air Traffic Control Radar Beacon System (ATCRBS). The transponder enables the ATC ground controller to "see" and identify the aircraft, while in flight, on the control center's radarscope more readily.

The Cessna 300 Transponder system consists of a panel-mounted unit and an externally-mounted antenna. The transponder receives interrogating pulse signals on 1030 MHz and transmits coded pulse-train reply signals on 1090 MHz. It is capable of replying to Mode A (aircraft identification) and Mode C (altitude reporting) interrogations on a selective reply basis on any of 4096 information code selections. When an optional panel-mounted EA-401A Encoding Altimeter (not part of a standard 300 Transponder system) is included in the avionic configuration, altitude reporting information is available in 100 foot increments.

All Cessna 300 Transponder operating controls, with the exception of the optional altitude encoder's altimeter setting knob, are located on the front panel of the unit. The altimeter setting knob is located on the encoding altimeter. Functions of the operating controls are described in Figure 1.

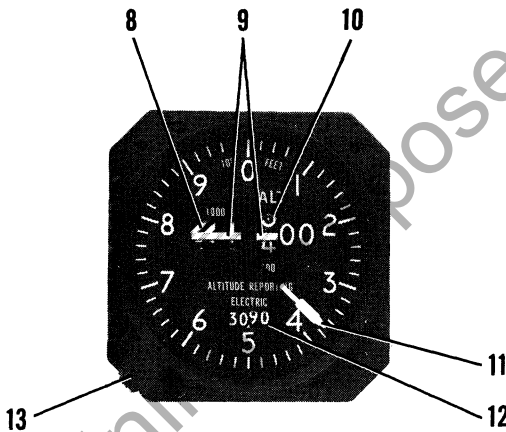
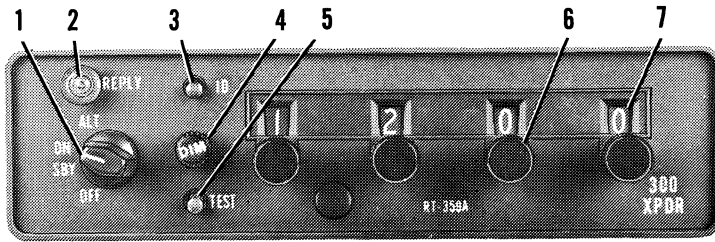

1. **FUNCTION SELECTOR SWITCH** - Controls application of power and selects transponder operating mode as follows:

**OFF** - Turns set off.

**SBY** - Turns set on for equipment warm-up.

**ON** - Turns set on and enables transponder to transmit Mode A (aircraft identification) reply pulses.

**ALT** - Turns set on and enables transponder to transmit both Mode A (aircraft identification) reply pulses and Mode C (altitude reporting) pulses selected automatically by the interrogating signal.

2. **REPLY LAMP** - Lamp flashes to indicate transmission of reply pulses; glows steadily to indicate transmission of IDENT pulse or satisfactory self-test operation. (Reply Lamp will also glow steadily during initial warm-up period.)

Figure 1. Cessna 300 Transponder and Encoding Altimeter (Sheet 1 of 2)

3. IDENT (ID) SWITCH - When depressed, selects special pulse identifier to be transmitted with transponder reply to effect immediate identification of aircraft on ground controller's display. (Reply Lamp will glow steadily during duration of IDENT pulse transmission.)
4. DIMMER (DIM) CONTROL - Allows pilot to control brilliance of reply lamp.
5. SELF-TEST (TST) SWITCH - When depressed, causes transponder to generate a self-interrogating signal to provide a check of transponder operation. (Reply Lamp will glow steadily to verify self test operation.)
6. REPLY-CODE SELECTOR KNOBS (4) - Select assigned Mode A reply code.
7. REPLY-CODE INDICATORS (4) - Display selected Mode A reply code.
8. 1000-FOOT DRUM TYPE INDICATOR - Provides digital altitude readout in 1000-foot increments between -1000 feet and +35,000 feet. When altitude is below 10,000 feet, a diagonally striped flag appears in the 10,000 foot window.
9. OFF INDICATOR WARNING FLAG - Flag appears across altitude readout when power is removed from the altimeter to indicate that readout is not reliable.
10. 100-FOOT DRUM TYPE INDICATOR - Provides digital altitude readout in 100-foot increments between 0 feet and 1000 feet.
11. 20-FOOT INDICATOR NEEDLE - Indicates altitude in 20-foot increments between 0 feet and 1000 feet.
12. ALTIMETER SETTING SCALE - DRUM TYPE - Indicates selected altimeter setting in the range of 27.9 to 31.0 inches of mercury on the standard altimeter or 950 to 1050 millibars on the optional altimeter.
13. ALTIMETER SETTING KNOB - Dials in desired altimeter setting in the range of 27.9 to 31.0 inches of mercury on the standard altimeter or 950 to 1050 millibars on the optional altimeter.

## SECTION 2 LIMITATIONS

There is no change to the airplane performance when this avionics equipment is installed. However, the encoding altimeter used in this installation does have a limitation that requires a standard barometric altimeter to be installed as a back-up altimeter.

Figure 1. Cessna 300 Transponder and Encoding Altimeter (Sheet 2 of 2)

## **SECTION 3**

### **EMERGENCY PROCEDURES**

TO TRANSMIT AN EMERGENCY SIGNAL:

1. Function Selector Switch -- ON.
2. Reply-Code Selector Knobs -- SELECT 7700 operating code.

TO TRANSMIT A SIGNAL REPRESENTING LOSS OF ALL COMMUNICATIONS (WHEN IN A CONTROLLED ENVIRONMENT):

1. Function Selector Switch -- ON.
2. Reply-Code Selector Knobs -- SELECT 7700 operating code for 1 minute; then SELECT 7600 operating code for 15 minutes and then REPEAT this procedure at same intervals for remainder of flight.

## **SECTION 4**

### **NORMAL PROCEDURES**

BEFORE TAKEOFF:

1. Function Selector Switch -- SBY.

TO TRANSMIT MODE A (AIRCRAFT IDENTIFICATION) CODES IN FLIGHT:

1. Reply-Code Selector Knobs -- SELECT assigned code.
2. Function Selector Switch -- ON.
3. DIM Control -- ADJUST light brilliance of reply lamp.

#### NOTE

During normal operation with function selector switch in ON position, reply lamp flashes indicating transponder replies to interrogations.

4. ID Button -- DEPRESS momentarily when instructed by ground controller to "squawk IDENT" (reply lamp will glow steadily, indicating IDENT operation).

## TO TRANSMIT MODE C (ALTITUDE REPORTING) CODES IN FLIGHT:

1. Off Indicator Warning Flag -- VERIFY that flag is out of view on encoding altimeter.
2. Altitude Encoder Altimeter Setting Knob -- SET IN assigned local altimeter setting.
3. Reply-Code Selector Knobs -- SELECT assigned code.
4. Function Selector Switch -- ALT.

## NOTE

When directed by ground controller to "stop altitude squawk", turn Function Selector Switch to ON for Mode A operation only.

## NOTE

Pressure altitude is transmitted by the transponder for altitude squawk and conversion to indicated altitude is done in ATC computers. Altitude squawked will only agree with indicated altitude when the local altimeter setting in use by the ground controller is set in the encoding altimeter.

5. DIM Control -- ADJUST light brilliance of reply lamp.

## TO SELF-TEST TRANSPONDER OPERATION:

1. Function Selector Switch -- SBY and wait 30 seconds for equipment to warm-up.
2. Function Selector Switch -- ON or ALT.
3. TST Button -- DEPRESS and HOLD (reply lamp should light with full brilliance regardless of DIM control setting).
4. TST Button -- RELEASE for normal operation.

## SECTION 5

### PERFORMANCE

There is no change to the airplane performance when this avionic equipment is installed. However, the installation of an externally mounted antenna or several related external antennas, will result in a minor reduction in cruise performance.

For Training Purposes Only



## SUPPLEMENT

# CESSNA NAVOMATIC 300A AUTOPILOT (Type AF-395A)

## SECTION 1 GENERAL

The Cessna 300A Navomatic is an all electric, single-axis (aileron control) autopilot system that provides added lateral and directional stability. Components are a computer-amplifier, a turn coordinator, a directional gyro, an aileron actuator and a course deviation indicator(s) incorporating a localizer reversed (BC) indicator light.

Roll and yaw motions of the airplane are sensed by the turn coordinator gyro. Deviations from the selected heading are sensed by the directional gyro. The computer-amplifier electronically computes the necessary correction and signals the actuator to move the ailerons to maintain the airplane in the commanded lateral attitude or heading.

The actuator includes a thermostatic switch which monitors the operating temperature of the motor. If the temperature becomes abnormal, the thermostatic switch opens and disengages the autopilot to remove power from the actuator. After approximately 10 minutes, the switch will automatically close to reapply power to the actuator and autopilot system.

The 300A Navomatic will also intercept and track a VOR or localizer course using signals from a VHF navigation receiver.

The operating controls for the Cessna 300A Navomatic are located on the front panel of the computer-amplifier and on the directional gyro, shown in Figure 1. The primary function pushbuttons (HDG SEL, NAV INT, and NAV TRK), are interlocked so that only one function can be selected at a time. The HI SENS and BACK CRS pushbuttons are not interlocked so that either or both of these functions can be selected at any time.

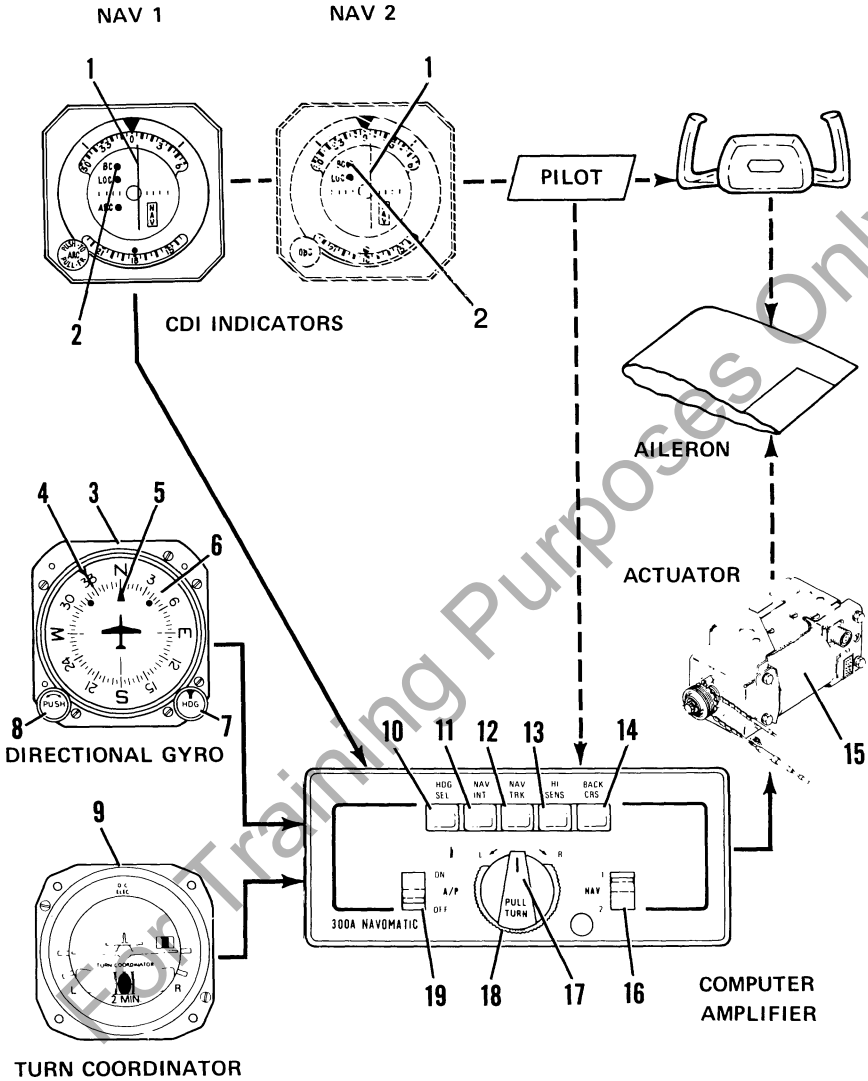

Figure 1. Cessna 300A Autopilot, Operating Controls and Indicators  
 (Sheet 1 of 3)

1. COURSE DEVIATION INDICATOR - Provides VOR/LOC navigation inputs to autopilot for intercept and tracking modes.
2. LOCALIZER REVERSED INDICATOR LIGHT - Amber light, labeled BC, illuminates when BACK CRS button is pushed in (engaged) and LOC frequency selected. BC light indicates course indicator needle is reversed on selected receiver (when tuned to a localizer frequency). This light is located within the CDI indicator.
3. NON-SLAVED DIRECTIONAL GYRO - Provides a stable visual indication of aircraft heading to the pilot and provides heading information to the autopilot for heading intercept and hold.
4. HEADING BUG - Moved by HDG knob to select desired heading.
5. LUBBER LINE - Indicates aircraft heading on compass card (6).
6. COMPASS CARD - Rotates to display heading of airplane with reference to lubber line (5).
7. HEADING SELECTOR KNOB (HDG) - When pushed in, the heading bug (4) may be positioned to the desired magnetic heading by rotating the HDG selector knob. Also used to select VOR or LOC course.
8. GYRO ADJUSTMENT KNOB (PUSH) - When pushed in, allows the pilot to manually rotate the compass card (6) to correspond with the magnetic heading indicated by the compass. The compass card must be manually reset periodically to compensate for precessional errors in the gyro.
9. TURN COORDINATOR - Senses roll and yaw for wings leveling and command turn functions.
10. HDG SEL PUSHBUTTON - Aircraft will turn to and hold heading selected by the heading "bug" on the directional gyro.
11. NAV INT PUSHBUTTON - When heading "bug" on DG is set to selected course, aircraft will turn to and intercept selected VOR or LOC course.
12. NAV TRK PUSHBUTTON - When heading "bug" on DG is set to selected course, aircraft will track selected VOR or LOC course.
13. HI SENS PUSHBUTTON - During NAV INT or NAV TRK operation, this high sensitivity setting increases autopilot response to NAV signal to provide more precise operation during localizer approach. In low-sensitivity position (push-button out), response to NAV signal is dampened for smoother tracking of enroute VOR radials; it also smooths out effect of course scalloping during NAV operation.
14. BACK CRS PUSHBUTTON - Used with LOC operation only. With A/P switch OFF or ON, and when navigation receiver selected by NAV switch is set to a localizer frequency, it reverses normal localizer needle indication (CDI) and causes localizer reversed (BC) light to illuminate. With A/P switch ON, reverses localizer signal to autopilot.

Figure 1. Cessna 300A Autopilot, Operating Controls and Indicators  
(Sheet 2 of 3)

15. ACTUATOR - The torque motor in the actuator causes the ailerons to move in the commanded direction.
16. NAV SWITCH - Selects NAV 1 or NAV 2 navigation receiver.
17. PULL TURN KNOB - When pulled out and centered in detent, airplane will fly wings-level; when turned to the right (R), the airplane will execute a right, standard rate turn; when turned to the left (L), the airplane will execute a left, standard rate turn. When centered in detent and pushed in, the operating mode selected by a pushbutton is engaged.
18. TRIM - Used to trim autopilot to compensate for minor variations in aircraft trim or lateral weight distribution. (For proper operation, the aircraft's rudder trim must be manually trimmed before the autopilot is engaged.)
19. A/P SWITCH - Turns autopilot ON or OFF.

Figure 1. Cessna 300A Autopilot, Operating Controls and Indicators  
(Sheet 3 of 3)

## SECTION 2 LIMITATIONS

The following autopilot limitation must be followed during airplane operation:

1. Autopilot must be OFF for takeoff and landing

OPERATING LIMITATION WITH AUTOPILOT ENGAGED:

1. Maximum Airspeed -- 155 KIAS.

## SECTION 3

### EMERGENCY PROCEDURES

TO OVERRIDE THE AUTOPILOT:

1. Airplane Control Wheel -- ROTATE as required to override auto-pilot.

#### NOTE

The servo may be overpowered at any time without damage.

TO TURN OFF AUTOPILOT:

1. A/P ON-OFF Switch -- OFF.

VACUUM SYSTEM FAILURE:

1. Pull Turn Knob -- PULL OUT AND CENTER.

#### NOTE

The autopilot may continue to be used as a wings leveller, but all heading and nav modes will be inoperative.

TURN COORDINATOR FAILURE:

1. A/P ON-OFF Switch -- OFF.

## SECTION 4

### NORMAL PROCEDURES

#### NOTE

If autopilot is to be turned on while airplane is on the ground, the control wheel should be held to prevent ailerons from banging stops and possibly damaging, or shearing, actuator shear pins.

## BEFORE TAKE-OFF AND LANDING:

1. A/P ON-OFF Switch -- OFF.
2. BACK CRS Button -- OFF (see Caution note under Nav Intercept).

## NOTE

Periodically verify operation of amber warning light(s), labeled BC on CDI(s), by engaging BACK CRS button with a LOC frequency selected.

## INFLIGHT WINGS LEVELING:

1. Airplane Rudder Trim -- ADJUST for zero slip ("Ball" centered on Turn Coordinator).
2. PULL-TURN Knob -- PULL out and CENTER.
3. A/P ON-OFF Switch -- ON.
4. Autopilot TRIM Control -- ADJUST for zero turn rate (wings level indication on Turn Coordinator).

## COMMAND TURNS:

1. PULL-TURN Knob -- PULL out and ROTATE.

## HEADING SELECT:

1. Directional Gyro -- SET to airplane magnetic heading.
2. Heading Selector Knob -- ROTATE bug to desired heading.
3. Heading Select Button -- PUSH.
4. PULL-TURN Knob -- CENTER and PUSH.

## NOTE

Airplane will turn automatically to selected heading. If airplane fails to hold the precise heading, readjust autopilot TRIM control as required or disengage autopilot and reset manual rudder trim (if installed).

## NAV INTERCEPT (VOR/LOC):

1. PULL-TURN Knob -- PULL out and CENTER.
2. NAV 1-2 Selector Switch -- SELECT desired receiver.
3. Nav Receiver OBS or ARC Knob -- SET desired VOR course (if tracking omni).

## NOTE

Optional ARC knob should be in center position and ARC warning light should be off.

4. Heading Selector Knob -- ROTATE bug to selected course (VOR or localizer - inbound or outbound as appropriate).
5. Directional Gyro --SET for magnetic heading.
6. NAV INT Button -- PUSH.
7. HI SENS Button -- PUSH for localizer and "close-in" omni intercepts.
8. BACK CRS Button -- PUSH only if intercepting localizer front course outbound or back course inbound.

**CAUTION**

With BACK CRS button pushed in and localizer frequency selected, the CDI on selected nav radio will be reversed even when the autopilot switch is OFF.

9. PULL-TURN Knob -- PUSH.

NOTE

Airplane will automatically turn to a 45° intercept angle.

NAV TRACKING (VOR/LOC):

1. NAV TRK Button -- PUSH when CDI centers (within one dot) and airplane is within  $\pm 10^\circ$  of course heading.
2. HI SENS Button -- Disengage for enroute omni tracking (leave engaged for localizer).

NOTE

Optional ARC function, if installed, should not be used for autopilot operation. If airplane should deviate off course, pull out PULL TURN knob and readjust airplane rudder trim for straight flight on the turn coordinator. Push in PULL TURN knob to reintercept course. If deviation persists, progressively make slight adjustments of autopilot TRIM control or heading bug on the directional gyro, towards the course as required to maintain track.

## SECTION 5 PERFORMANCE

There is no change to the airplane performance when this avionic equipment is installed.

For Training Purposes Only



## SUPPLEMENT

# CESSNA 400 GLIDE SLOPE

(Type R-443B)

## SECTION 1 GENERAL

The Cessna 400 Glide Slope is an airborne navigation receiver which receives and interprets glide slope signals from a ground-based Instrument Landing System (ILS). It is used with the localizer function of a VHF navigation system when making instrument approaches to an airport. The glide slope provides vertical path guidance while the localizer provides horizontal track guidance.

The Cessna 400 Glide Slope system consists of a remote-mounted receiver coupled to an existing navigation system, a panel-mounted indicator and an externally mounted antenna. The glide slope receiver is designed to receive ILS glide slope signals on any of 40 channels. The channels are spaced 150 kHz apart and cover a frequency range of 329.15 MHz through 335.0 MHz. When a localizer frequency is selected on the NAV receiver, the associated glide slope frequency is selected automatically.

Operation of the Cessna 400 Glide Slope system is controlled by the associated navigation system. The functions and indications of typical 300 and 400 series glide slope indicators are pictured and described in Figure 1. The glide slope indicators shown in Figure 1 depict typical indications for Cessna-crafted glide slope indicators. However, refer to the RNAV or HSI write-ups if they are listed in this section as options for additional glide slope indicators.

## SECTION 2 LIMITATIONS

There is no change to the airplane limitations when this avionics equipment is installed.

## TYPICAL 300 &amp; 400 SERIES GLIDE SLOPE INDICATORS

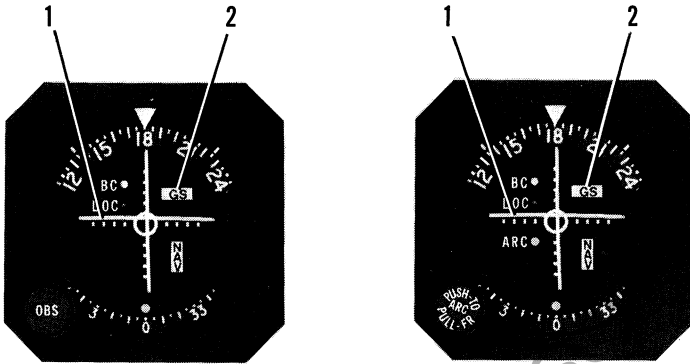

1. GLIDE SLOPE DEVIATION POINTER - Indicates deviation from normal glide slope. The rectilinear, horizontal pointer stows to top of indicator (out of view) when power is removed or Navigation System is set to a VOR frequency.
2. GLIDE SLOPE "OFF" OR "GS" FLAG - When visible, indicates unreliable glide slope signal or improperly operating equipment. The flag disappears when a reliable glide slope signal is being received.

**CAUTION**

Spurious glide slope signals may exist in the area of the localizer back course approach which can cause the glide slope "OFF" or "GS" flag to disappear and present unreliable glide slope information. Disregard all glide slope signal indications when making a localizer back course approach unless a glide slope (ILS BC) is specified on the approach and landing chart.

Figure 1. Typical 300 Series VOR/LOC/ILS Indicator

## SECTION 3 EMERGENCY PROCEDURES

There is no change to the airplane emergency procedures when this avionic equipment is installed.

## SECTION 4 NORMAL PROCEDURES

TO RECEIVE GLIDE SLOPE SIGNALS:

### NOTE

The pilot should be aware that on Cessna airplanes equipped with the vertical fin mounted glide slope antenna, pilots should avoid use of 2700  $\pm$ 100 RPM on airplanes equipped with a two-bladed propeller or 1800  $\pm$ 100 RPM on airplanes equipped with a three-bladed propeller during ILS approaches to avoid any possibility of oscillations of the glide slope deviation pointer caused by propeller interference.

1. NAV Frequency Select Knobs -- SELECT desired localizer frequency (glide slope frequency is automatically selected).
2. NAV/COM VOX-ID-T Switch -- SELECT ID position to disconnect filter from audio circuit.
3. NAV VOL Control -- ADJUST to desired listening level to confirm proper localizer station.

### CAUTION

When glide slope "OFF" or "GS" flag is visible, glide slope indications are unusable.

## SECTION 5 PERFORMANCE

There is no change to the airplane performance when this avionic equipment is installed.

For Training Purposes Only

## SUPPLEMENT

# CESSNA 400 MARKER BEACON (Type R-402)

## SECTION 1 GENERAL

The system consists of a remote mounted 75 MHz marker beacon receiver, an antenna which is either flush mounted or externally mounted on the under side of the aircraft and operating controls and annunciator lights which are mounted on the front of the audio control panel.

Operating controls for the marker beacon system are supplied on the front of the two types of audio control panels used in this Cessna aircraft. The operating controls for the marker beacon are different on the two audio control panels. One type of audio control panel is supplied with one or two transmitters and the other is supplied with three transmitters.

The marker beacon operating controls and annunciator lights used on the audio control panel supplied with two or less transmitters are shown and described in Figure 1. The operating controls consist of three, three-position toggle switches. One switch is labeled "HIGH/LO/MUTE" and provides the pilot with HIGH-LO sensitivity selection and marker beacon audio muting, for approximately 30 seconds, to enable voice communication to be heard without interference of marker beacon signals. The marker beacon audible tone is automatically restored at the end of the 30 second muting period to continue marker audio for passage over the next marker. Another switch is labeled "SPKR/OFF/PHN" and is used to turn the set on and select the desired speaker or phone position for marker beacon signals. The third toggle switch labeled, "ANN LT", is provided to enable the pilot to select the desired DAY or NITE lighting position for annunciator lights, and also a "TEST" position to verify operation of marker beacon annunciator lights.

The marker beacon operating controls and annunciator lights used on the audio control panel supplied with three transmitters are shown and described in Figure 2. The operating controls consist of two, three-position toggle switches, and two concentric control knobs. One switch is labeled "SPKR/PHN" and is used to select the desired speaker or phone position for marker beacon signals. The other switch is labeled "HI/LO/TEST" and

provides the pilot with HI-LO sensitivity selection and a TEST position to verify operation of all annunciator lights. The small, inner control knob labeled OFF/VOL, turns the set on or off and adjusts the audio listening level. The large, outer control knob labeled BRT, provides light dimming for the marker beacon lights.

When the Cessna 400 Marker Beacon controls are incorporated in an audio control panel incorporated with two or less transmitters a marker Beacon audio level adjustment potentiometer and an annunciator lights minimum dimming potentiometer are mounted on the audio control panel circuit board. Potentiometer adjustments cannot be accomplished externally. However, if readjustments are desired, adjustments can be made in accordance with instructions found in the Avionics Installations Service/Parts Manual for this aircraft.

## MARKER FACILITIES

MARKER	IDENTIFYING TONE	LIGHT*
Inner & Fan	Continuous 6 dots/sec (3000 Hz)	White
Back Course	72-95 two dot combinations per minute (3000 Hz)	White
Middle	Alternate dots and dashes (1300 Hz)	Amber
Outer	2 dashes/sec (400 Hz)	Blue

\* When the identifying tone is keyed, the respective indicating light will blink accordingly.

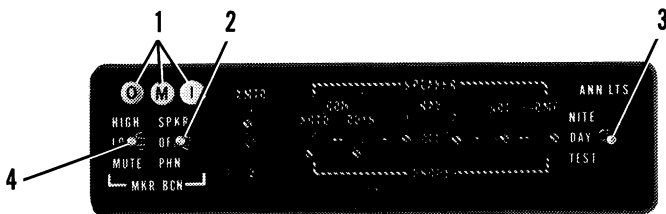

### AUDIO CONTROL PANEL FOR USE WITH ONE OR TWO TRANSMITTERS

1. MARKER BEACON ANNUNCIATOR LIGHTS:

OUTER - Light illuminates blue to indicate passage of outer marker beacon.  
MIDDLE - Light illuminates amber to indicate passage of middle marker beacon.  
INNER - Light illuminates white to indicate passage of inner, fan, or back course marker beacons.

2. SPEAKER/OFF/PHONE SELECTOR SWITCH:

SPEAKER POSITION - Turns set on and selects speaker for aural reception.  
OFF POSITION - Turns set off.  
PHONE POSITION - Turns set on and selects phone for aural reception.

3. ANNUNCIATOR LIGHTS SWITCH:

NITE POSITION - Places the annunciator lights in a dim lighting mode for night flying operations. Light intensity of the NITE position is controlled by the RADIO LT dimming rheostat.  
DAY POSITION - Places the annunciator lights in the full bright position for daylight flying operations.  
TEST POSITION - Illuminates all marker beacon annunciator lights in the full bright position to verify operation of marker beacon lights.

4. HIGH/LO/MUTE SELECTOR SWITCH:

HIGH POSITION - Receiver sensitivity is positioned for airway flying.  
LO POSITION - Receiver sensitivity is positioned for ILS approaches.  
MUTE POSITION - The marker beacon audio signals are temporarily blanked out (for approximately 30 seconds) and then automatically restored, over the speaker or headset in order to provide voice communications without interference of marker beacon signals.

Figure 1. Cessna 400 Marker Beacon Operating Controls and Indicator Lights Supplied with Two or Less Transmitters

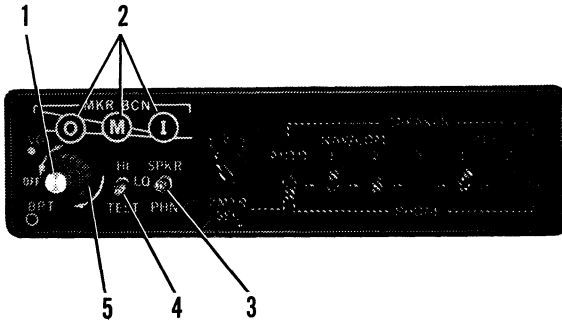

### AUDIO CONTROL PANEL FOR USE WITH THREE TRANSMITTERS

#### 1. OFF/VOLUME CONTROL:

OFF/VOL - Turns the set on or off and adjusts the audio listening level. Clockwise rotation of the smaller knob turns the set on and increases the audio level.

#### 2. MARKER BEACON ANNUNCIATOR LIGHTS:

OUTER - Light illuminates blue to indicate passage of outer marker beacon.

MIDDLE - Light illuminates amber to indicate passage of middle marker beacon.

INNER - Light illuminates white to indicate passage of inner, fan, or back course marker beacons.

#### 3. SPEAKER/PHONE SELECTOR SWITCH:

SPEAKER POSITION - Selects speaker for aural reception.

PHONE POSITION - Selects headphone for aural reception.

#### 4. HI/LO/TEST SELECTOR SWITCH:

HI POSITION - Receiver sensitivity is positioned for airway flying.

LO POSITION - Receiver sensitivity is positioned for ILS approaches.

TEST POSITION - Illuminates marker beacon annunciator lights in the full bright position to verify operation of marker beacon lights.

#### 5. LIGHT DIMMING CONTROL:

BRT - Provides light dimming for the annunciator lights. Clockwise rotation of the larger knob increases light intensity.

Figure 2. Cessna 400 Marker Beacon Operating Controls and Indicator Lights Supplied With Three Transmitters.



## SECTION 2 LIMITATIONS

There is no change to the airplane limitations when this avionic equipment is installed.

## SECTION 3 EMERGENCY PROCEDURES

There is no change to the airplane emergency procedures when this avionic equipment is installed.

## SECTION 4 NORMAL PROCEDURES

MARKER BEACON OPERATING PROCEDURES FOR USE WITH AUDIO CONTROL PANELS PROVIDED WITH ONE OR TWO TRANSMITTERS (REF. FIG. 1)

1. SPKR/OFF/PHN Selector Switch -- SELECT desired speaker or phone audio. Either selected position will turn set on.
2. NITE/DAY/TEST Selector Switch -- PRESS to TEST position and verify that all marker beacon annunciator lights illuminate full bright to indicate lights are operational.
3. NITE/DAY/TEST Selector Switch -- SELECT desired position for NITE or DAY lighting.
4. HIGH/LO/MUTE Selector Switch -- SELECT HI position for airway flying or LO position for ILS approaches.

### NOTE

Press MUTE switch to provide an approximate 30 seconds temporary blanking out of Marker Beacon audio tone. The marker beacon audio tone identifier is automatically restored at the end of the muting period.

## NOTE

Due to the short distance typical between the middle marker and inner marker, audio identification of an inner marker may not be possible if muting is activated over the middle marker.

MARKER BEACON OPERATING PROCEDURES FOR USE WITH AUDIO CONTROL PANELS PROVIDED WITH THREE TRANSMITTERS. (REF. FIG. 2)

1. OFF/VOL Control -- TURN to VOL position and adjust to desired listening level. Clockwise rotation increases audio level.
2. HI/LO Sen Switch -- SELECT HI position for airway flying or LO position for ILS approaches.
3. SPKR/PHN Switch -- SELECT speaker or phone audio.
4. BRT Control -- SELECT BRT (full clockwise). ADJUST as desired when illuminated over marker beacon.
5. TEST Switch -- PRESS to TEST position and verify that all marker beacon annunciator lights will illuminate full bright to indicate lights are operational.

## SECTION 5

### PERFORMANCE

There is no change to the airplane performance when this avionic equipment is installed. However, the installation of an externally mounted antenna or several related external antennas, will result in a minor reduction in cruise performance.

**SUPPLEMENT**  
**CESSNA 400 TRANSPONDER**  
**(Type RT-459A)**  
**AND**  
**OPTIONAL ALTITUDE ENCODER (BLIND)**

**SECTION 1**  
**GENERAL**

The Cessna 400 Transponder (Type RT-459A), shown in Figure 1, is the airborne component of an Air Traffic Control Radar Beacon System (ATCRBS). The transponder enables the ATC ground controller to "see" and identify the aircraft, while in flight, on the control center's radarscope more readily.

The Cessna 400 Transponder system consists of a panel-mounted unit and an externally mounted antenna. The transponder receives interrogating pulse signals on 1030 MHz and transmits pulse-train reply signals on 1090 MHz. The transponder is capable of replying to Mode A (aircraft identification) and also to Mode C (altitude reporting) when coupled to an optional altitude encoder system. The transponder is capable of replying on both modes of interrogation on a selective reply basis on any of 4,096 information code selections. The optional altitude encoder system (not part of a standard 400 Transponder system) required for Mode C (altitude reporting) operation, consists of a completely independent remote-mounted digitizer that is connected to the static system and supplies encoded altitude information to the transponder. When the altitude encoder system is coupled to the 400 Transponder system, altitude reporting capabilities are available in 100-foot increments between -1000 feet and the airplane's maximum service ceiling.

All Cessna 400 Transponder operating controls are located on the front panel of the unit. Functions of the operating controls are described in Figure 1.

**19**  
CESSNA 400 TRANSPONDER AND ALTITUDE ENCODER (BLIND) PILOT'S OPERATING HANDBOOK  
AND ALTITUDE ENCODER (BLIND) SUPPLEMENT

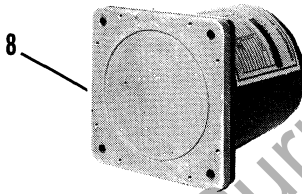
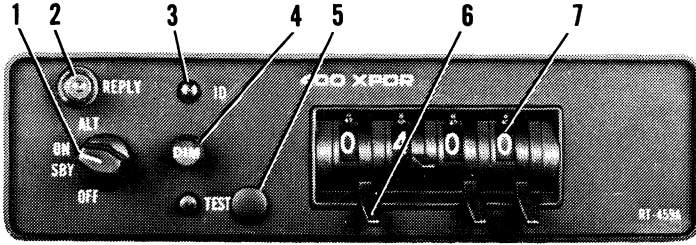

1. **FUNCTION SELECTOR SWITCH** - Controls application of power and selects transponder operating mode as follows:
  - OFF - Turns set off.
  - SBY - Turns set on for equipment warm-up or standby power.
  - ON - Turns set on and enables transponder to transmit Mode A (aircraft identification) reply pulses.
  - ALT - Turns set on and enables transponder to transmit both Mode A (aircraft identification) reply pulses and Mode C (altitude reporting) pulses selected automatically by the interrogating signal.
2. **REPLY LAMP** - Lamp flashes to indicate transmission of reply pulses; glows steadily to indicate transmission of IDENT pulse or satisfactory self-test operation. (Reply lamp will also glow steadily during initial warm-up period.)

Figure 1. Cessna 400 Transponder and Altitude Encoder (Blind)  
(Sheet 1 of 2)

3. IDENT (ID) SWITCH - When depressed, selects special pulse identifier to be transmitted with transponder reply to effect immediate identification of aircraft on ground controller's display. (Reply lamp will glow steadily during duration of IDENT pulse transmission.)
4. DIMMER (DIM) CONTROL - Allows pilot to control brilliance of reply lamp.
5. SELF-TEST (TEST) SWITCH - When depressed, causes transponder to generate a self-interrogating signal to provide a check of transponder operation. (Reply lamp will glow steadily to verify self-test operation.)
6. REPLY-CODE SELECTOR SWITCHES (4) - Select assigned Mode A reply code.
7. REPLY-CODE INDICATORS (4) - Display selected Mode A reply code.
8. REMOTE-MOUNTED DIGITIZER - Provides an altitude reporting code range from -1000 feet up to the airplane's maximum service ceiling.

Figure 1. Cessna 400 Transponder and Altitude Encoder (Blind)  
(Sheet 2 of 2)

## SECTION 2 LIMITATIONS

There is no change to the airplane limitations when this avionic equipment is installed. However, the following information must be displayed in the form of a placard located near the altimeter.

ALTITUDE ENCODER EQUIPPED

## SECTION 3 EMERGENCY PROCEDURES

TO TRANSMIT AN EMERGENCY SIGNAL:

1. Function Selector Switch -- ON.
2. Reply-Code Selector Switches -- SELECT 7700 operating code.

TO TRANSMIT A SIGNAL REPRESENTING LOSS OF ALL COMMUNICATIONS (WHEN IN A CONTROLLED ENVIRONMENT):

1. Function Selector Switch -- ON.
2. Reply-Code Selector Switches -- SELECT 7700 operating code for 1 minute; then SELECT 7600 operating code for 15 minutes and then REPEAT this procedure at same intervals for remainder of flight.

## SECTION 4 NORMAL PROCEDURES

BEFORE TAKEOFF:

1. Function Selector Switch -- SBY.

TO TRANSMIT MODE A (AIRCRAFT IDENTIFICATION) CODES IN FLIGHT:

1. Reply-Code Selector Switches -- SELECT assigned code.

2. Function Selector Switch -- ON.
3. DIM Control -- ADJUST light brilliance of reply lamp.

NOTE

During normal operation with function switch in ON position, reply lamp flashes indicating transponder replies to interrogations.

4. ID or XPDR IDENT Button -- DEPRESS momentarily when instructed by ground controller to "squawk IDENT" (reply lamp will glow steadily, indicating IDENT operation).

TO TRANSMIT MODE C (ALTITUDE REPORTING) CODES IN FLIGHT:

1. Reply-Code Selector Switches -- SELECT assigned code.
2. Function Selector Switch -- ALT.

NOTE

When directed by ground controller to "stop altitude squawk", turn Function Selector Switch to ON for Mode A operation only.

NOTE

Pressure altitude is transmitted by the transponder for altitude squawk and conversion to indicated altitude is done in ATC computers. Altitude squawked will only agree with indicated altitude when the local altimeter setting in use by the ground controller is set in the aircraft altimeter.

3. DIM Control -- ADJUST light brilliance of reply lamp.

TO SELF-TEST TRANSPONDER OPERATION:

1. Function Selector Switch -- SBY and wait 30 seconds for equipment to warm-up.
2. Function Selector Switch -- ON.
3. TEST Button -- DEPRESS (reply lamp should light brightly regardless of DIM control setting).
4. TEST Button -- RELEASE for normal operation.

## **SECTION 5**

### **PERFORMANCE**

There is no change to the airplane performance when this avionic equipment is installed. However, the installation of an externally mounted antenna or several related external antennas, will result in a minor reduction in cruise performance.

For Training Purposes Only



**SUPPLEMENT**  
**CESSNA 400 TRANSPONDER**  
**(Type RT-459A)**  
**AND**  
**OPTIONAL ENCODING ALTIMETER**  
**(Type EA-401A)**

**SECTION 1**  
**GENERAL**

The Cessna 400 Transponder (Type RT-459A), shown in Figure 1, is the airborne component of an Air Traffic Control Radar Beacon System (ATCRBS). The transponder enables the ATC ground controller to "see" and identify the aircraft, while in flight, on the control center's radarscope more readily.

The 400 Transponder consists of a panel-mounted unit and an externally mounted antenna. The transponder receives interrogating pulse signals on 1030 MHz and transmits coded pulse-train reply signals on 1090 MHz. It is capable of replying to Mode A (aircraft identification) and Mode C (altitude reporting) interrogations on a selective reply basis on any of 4,096 information code selections. When an optional panel mounted EA-401A Encoding Altimeter (not part of 400 Transponder System) is included in the avionic configuration, the transponder can provide altitude reporting in 100-foot increments between -1000 and +35,000 feet.

All Cessna 400 Transponder operating controls, with the exception of the optional altitude encoder's altimeter setting knob, are located on the front panel of the unit. The altimeter setting knob is located on the encoding altimeter. Functions of the operating controls are described in Figure 1.

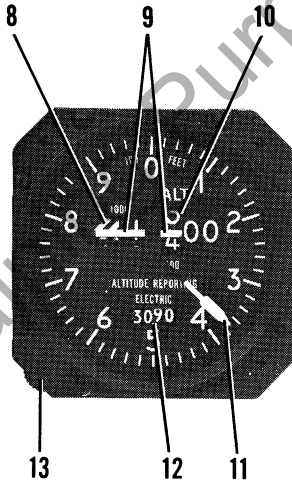
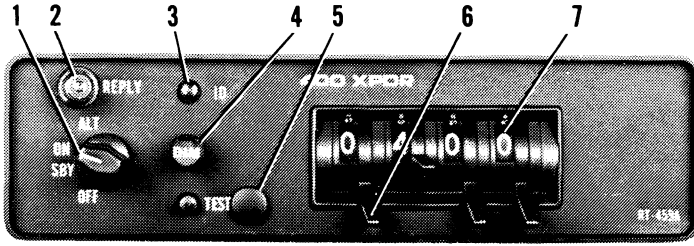

Figure 1. Cessna 400 Transponder and Encoding Altimeter  
Operating Controls (Sheet 1 of 2)

1. **FUNCTION SELECTOR SWITCH** - Controls application of power and selects transponder operating mode as follows:
  - OFF - Turns set off.
  - SBY - Turns set on for equipment warm-up or standby power.
  - ON - Turns set on and enables transponder to transmit Mode A (aircraft identification) reply pulses.
  - ALT - Turns set on and enables transponder to transmit both Mode A (aircraft identification) reply pulses and Mode C (altitude reporting) pulses selected automatically by the interrogating signal.
2. **REPLY LAMP** - Lamp flashes to indicate transmission of reply pulses; glows steadily to indicate transmission of IDENT pulse or satisfactory self-test operation. (Reply Lamp will also glow steadily during initial warm-up period.)
3. **IDENT (ID) SWITCH** - When depressed, selects special pulse identifier to be transmitted with transponder reply to effect immediate identification of aircraft on ground controller's display. (Reply Lamp will glow steadily during duration of IDENT pulse transmission.)
4. **DIMMER (DIM) CONTROL** - Allows pilot to control brilliance of Reply Lamp.
5. **SELF-TEST (TEST) SWITCH** - When depressed, causes transponder to generate a self-interrogating signal to provide a check of transponder operation. (Reply Lamp will glow steadily to verify self test operation.)
6. **REPLY-CODE SELECTOR SWITCHES (4)** - Select assigned Mode A Reply Code.
7. **REPLY-CODE INDICATORS (4)** - Display selected Mode A Reply Code.
8. **1000-FOOT DRUM TYPE INDICATOR** - Provides digital altitude readout in 1000-foot increments between -1000 and +35,000 feet. When altitude is below 10,000 feet, a diagonally striped flag appears in the 10,000-foot window.
9. **OFF INDICATOR WARNING FLAG** - Flag appears across altitude readout when power is removed from altimeter to indicate that readout is not reliable.
10. **100-FOOT DRUM TYPE INDICATOR** - Provides digital altitude readout in 100-foot increments between 0 feet and 1000 feet.
11. **20-FOOT INDICATOR NEEDLE** - Indicates altitude in 20-foot increments between 0 feet and 1000 feet.
12. **ALTIMETER SETTING SCALE - DRUM TYPE** - Indicates selected altimeter setting in the range of 27.9 to 31.0 inches of mercury on the standard altimeter or 950 to 1050 millibars on the optional altimeter.
13. **ALTIMETER SETTING KNOB** - Dials in desired altimeter setting in the range of 27.9 to 31.0 inches of mercury on standard altimeter or 950 to 1050 millibars on the optional altimeter.

Figure 1. Cessna 400 Transponder and Encoding Altimeter  
Operating Controls (Sheet 2 of 2)

## SECTION 2

### LIMITATIONS

There is no change to the airplane performance when this avionic equipment is installed. However, the encoding altimeter used in this installation does have a limitation that requires a standard barometric altimeter be installed as a back-up altimeter.

## SECTION 3

### EMERGENCY PROCEDURES

TO TRANSMIT AN EMERGENCY SIGNAL:

1. Function Selector Switch -- ON.
2. Reply-Code Selector Switches -- SELECT 7700 operating code.

TO TRANSMIT A SIGNAL REPRESENTING LOSS OF ALL COMMUNICATIONS (WHEN IN A CONTROLLED ENVIRONMENT):

1. Function Selector Switch -- ON.
2. Reply-Code Selector Switches -- SELECT 7700 operating code for 1 minute; then SELECT 7600 operating code for 15 minutes and then REPEAT this procedure at same intervals for remainder of flight.

## SECTION 4

### NORMAL PROCEDURES

BEFORE TAKEOFF:

1. Function Selector Switch -- SBY.

TO TRANSMIT MODE A (AIRCRAFT IDENTIFICATION) CODES IN FLIGHT:

1. Reply-Code Selector Switches -- SELECT assigned code.

2. Function Selector Switch -- ON.
3. DIM Control -- ADJUST light brilliance of reply lamp.

## NOTE

During normal operation with function switch in ON position, REPLY lamp flashes indicating transponder replies to interrogations.

4. ID or XPDR IDENT Button -- DEPRESS momentarily when instructed by ground controller to "squawk IDENT" (REPLY lamp will glow steadily, indicating IDENT operation).

## TO TRANSMIT MODE C (ALTITUDE REPORTING) CODES IN FLIGHT:

1. Off Indicator Warning Flag -- VERIFY that flag is out of view on encoding altimeter.
2. Altitude Encoder Altimeter Setting Knob -- SET IN assigned local altimeter setting.
3. Reply-Code Selector Switches -- SELECT assigned code.
4. Function Selector Switch -- ALT.

## NOTE

When directed by ground controller to "stop altitude squawk", turn Function Selector Switch to ON for Mode A operation only.

## NOTE

Pressure altitude is transmitted by the transponder for altitude squawk and conversion to indicated altitude is done in ATC computers. Altitude squawked will only agree with indicated altitude when the local altimeter setting in use by the ground controller is set in the encoding altimeter.

5. DIM Control -- ADJUST light brilliance of reply lamp.

## TO SELF-TEST TRANSPONDER OPERATION:

1. Function Selector Switch -- SBY and wait 30 seconds for equipment to warm-up.
2. Function Selector Switch -- ON or ALT.
3. TEST Button -- DEPRESS and HOLD (reply lamp should light with full brilliance regardless of DIM control setting).
4. TST Button -- RELEASE for normal operation.

## **SECTION 5**

### **PERFORMANCE**

There is no change to the airplane performance when this avionic equipment is installed. However, the installation of an externally mounted antenna or several related external antennas, will result in a minor reduction in cruise performance.

For Training Purposes Only

For Training Purposes Only

For Training Purposes Only